

**TECHNICAL  
TRANSACTIONS**

**CZASOPISMO  
TECHNICZNE**

**ARCHITECTURE**

**ARCHITEKTURA**

**ISSUE  
8-A (15)**

**ZESZYT  
8-A (15)**

**YEAR  
2014 (111)**

**ROK  
2014 (111)**



**WYDAWNICTWO  
POLITECHNIKI  
KRAKOWSKIEJ**

# TECHNICAL TRANSACTIONS

## ARCHITECTURE

ISSUE 8-A (15)  
YEAR 2014 (111)

# CZASOPISMO TECHNICZNE

## ARCHITEKTURA

ZESZYT 8-A (15)  
ROK 2014 (111)

Chairman of the Cracow University  
of Technology Press Editorial Board

**Jan Kazior**

Przewodniczący Kolegium  
Redakcyjnego Wydawnictwa  
Politechniki Krakowskiej

Chairman of the Editorial Board

**Józef Gawlik**

Przewodniczący Kolegium  
Redakcyjnego Wydawnictw  
Naukowych

Scientific Council

**Jan Błachut  
Tadeusz Burczyński  
Leszek Demkowicz  
Joseph El Hayek  
Zbigniew Florjańczyk  
Józef Gawlik  
Marian Giżejowski  
Sławomir Gzell  
Allan N. Hayhurst  
Maria Kuśnierova  
Krzysztof Magnucki  
Herbert Mang  
Arthur E. McGarity  
Antonio Monestiroli  
Günter Wozny  
Roman Zarzycki**

Rada Naukowa

Architecture Series Editor

**Dariusz Kozłowski**

Redaktor Serii Architektura

Section Editor

**Dorota Sapek**

Sekretarz Sekcji

Editorial Compilation

**Aleksandra Urzędowska**

Opracowanie redakcyjne

Typesetting

**Krystyna Gawlik**

Skład i łamanie

Native Speaker

**Jacek Paluszynski**

Weryfikacja językowa

Cover Design

**Michał Graffstein**

Projekt okładki

Cover Photo

**Jacek Gyurkovich**

Zdjęcie na okładce

Basic version of each Technical Transactions magazine is its online version

Pierwotną wersją każdego zeszytu Czasopisma Technicznego jest jego wersja online

[www.ejournals.eu/Czasopismo-Techniczne](http://www.ejournals.eu/Czasopismo-Techniczne)

[www.technicaltransactions.com](http://www.technicaltransactions.com)

[www.czasopismotechniczne.pl](http://www.czasopismotechniczne.pl)



**Architecture Series**  
**8-A/2014**

**Editorial Board**

**Editor-in-Chief:**

Dariusz Kozłowski, Cracow University of Technology, Poland

**Editorial Board:**

Wojciech Bonenberg, Poznan University of Technology, Poland

Herbert Bühler, University of Münster, Germany

Carlos Marmolejo Duarte, Universitat Politècnica de Catalunya, Spain

Armando Dal Fabbro, Università IUAV di Venezia, Italy

Raimund Fein, Brandenburg University of Technology Cottbus–Senftenberg, Germany

Madelyn Marrero Melendez, University of Seville, Spain

Alberto Pratelli, University of Udine, Italy

Juan Luis Trillo de Leyva, Superior Technical School of Architecture of Seville, Spain

Elżbieta Trocka-Leszczyńska, Wrocław University of Technology, Poland

Stefan Wrona, Warsaw University of Technology, Poland

**Executive Editors:**

Wacław Celadyn, Cracow University of Technology, Poland

Sabina Kuc, Cracow University of Technology, Poland

LANSCAPING

---

KRAJOBRAZ





MAGDALENA CHUDY\*

## VERTICAL GARDEN

---

## WERTYKALNY OGRÓD

### Abstract

The constant expansion and intensification of urbanized areas resulting in microclimate deterioration, high air pollution and dust pollution levels, as well as noise provoking a response and a rise in urban greenery, is currently observed. In this context, the subject of green walls also known as vertical gardens subscribes to the notion of sustainable design and its growing popularity manifests the unbreakable bond between man and nature. One cannot overestimate the importance of green wall technology, which provides architects with new ecological elevation material, offering an unlimited number of textures and colour effects, changing according to the time of the day and season, and sometimes unpredictable even for the designer himself.

*Keywords: vertical garden, green wall, façade, sustainable design, nature, human-being*

### Streszczenie

Nieustanna ekspansja i intensyfikacja terenów zurbanizowanych, powodująca pogorszenie mikroklimatu, wysoki poziom zanieczyszczenia i zapylenia powietrza oraz hałas wywołały reakcję i obecnie obserwuje się wzrost znaczenia zieleni w mieście. Rozpatrywane w tym kontekście zagadnienie zielonych ścian- tak zwanych wertykalnych ogrodów wpisuje się w nurt projektowania zrównoważonego, a jego rosnąca popularność jest manifestacją nierozzerwalnego związku człowieka z naturą. Znaczenie technologii zielonych ścian, która daje do dyspozycji architektowi nowy, ekologiczny materiał elewacyjny, oferujący nieograniczoną liczbę faktur i efektów kolorystycznych, zmieniających się w porze dnia i roku, czasami niemożliwych do przewidzenia dla samego projektanta, jest nie do przecenienia.

*Słowa kluczowe: wertykalny ogród, zielona ściana, elewacja, zrównoważony rozwój, natura, człowiek*

---

\* M.Sc. Arch. Magdalena Chudy, Ph.D. Studies, Faculty of Architecture, Cracow University of Technology.



## 1. Introduction

The constant expansion and intensification of urbanized areas, resulting in microclimate deterioration, high air pollution and dust pollution levels, as well as noise provoking a response and a rise in urban greenery, is currently observed. This is confirmed by the fact that one of the most promoted and dynamically developing trends in designing is sustainable design. Such words as 'Eco' or 'Green' became the intrinsic elements of colloquial language. Increasingly, we are also finding green walls in architecture. The question arises as to whether the green wall technology, also known as 'vertical gardens' in context of its energy intensity, complexity of creating, maintaining and usage of non-biodegradable building materials, has an actual beneficial influence on the environment or it only looks green.

## 2. Constructing a vertical garden

The vertical garden benefits from the fact that in order to survive, plants need light, carbon dioxide, suitable temperature, water and minerals. Contrary to general beliefs, plants can vegetate without soil. This observation allowed French botanist Patrick Blanc to start creating and patented his first green walls called vertical gardens. They were inspired with tropical landscapes where plants, which have optimal conditions of habitat, grow directly on rocks [1]. The broader view on the genesis of the idea of a vertical gardens' creation, is provided by W. Kosiński referring to cultural examples. *Inter alia* refers to Babylon Gardens, traditional gardening art related to residential architecture and pitched roofs covered with grass of regional Scandinavian architecture [4]. The term of vertical garden covers *inter alia* systems providing the opportunity for plants to grow in properly shaped wall layers made on the construction site; modular systems prefabricated, delivered and combined at the investment spot, building walls, support installations made of iron nets, bars or ties and acoustic screens covered with creepers creating green vertical surfaces ingrained in the soil.

In order to maintain a vertical garden on an artificial wall in the city and at the same time to ensure the security of the building, it is necessary to make a supporting construction and plan watering and nutrition systems.

The vertical garden authored by Patrick Blanc in cross section consists of three parts: a supporting construction, waterproof layer which protects the building wall from water and a vegetation layer where plants take root. The watering system is placed between layers of felt. Each of the layers can be formed into any shape. The supporting construction usually takes the form of a light metal frame, which is hung on a free standing wall or an already existing wall of a building. The waterproof layer is a standard 1 cm thick PCV sheet; this layer not only protects against water, but it also brings stiffness to the whole structure. As the substrate, on which plants can take root, a thick felt layer is used. The felt made from polyamide is resistant to biodegradation and it also provides retention and distribution of water and microelements. The watering system should provide continuous water circulation. The watering process begins from the top of the wall. Then water is supplied successively to the roots of plants planted below. Unused water flows down on the felt layer and is collected on the bottom and pumped to the top to be re-used. Many watering systems can

be programmed automatically which makes the system more efficient and the mixture of nutrients can be adjusted in accordance with plants' needs in a given part of the day [1, 10].

The choice of plant species is strictly dependent on climate conditions and exposure of the wall. The height of a building is also significant. The higher plants are installed, the greater their resistance to extreme temperature, wind and sunlight should be. The plants should be light, their root system must be spreading and not of the pile form. It is also important to choose evergreen plants, so that a vertical garden will fulfill its role throughout the whole year [2]. An additional guideline for shaping the vertical garden is the functional aspect. In order to provide a wide passage round the building it is recommended to situate smaller plants on the lower part of the wall and shrubby ones higher up [1]. Life expectancy is an important factor while calculating the cost of green wall exploitation. It is recommended to choose mosses, ornamental grasses, perennials, shrubs which live a few to dozens of years with a high tolerance to environmental pollution. Aging and withered plants should be replaced during a garden maintaining process of minimum every half year.

All mentioned above materials that are used to construct a vertical garden are non-biodegradable, it means that they are not subjected to decomposition influenced by biological factors. This is necessary because of providing fire security and durability of the construction.

### **3. Functioning of the vertical garden in a city**

The popularity of the vertical garden has begun together with the success of Patrick Blanc, achieved during the International Garden Festival in Chaumont-sur-Loire in 1994. The presented structure in the form of a wall covered with plants attracted the interest of artists, followed by architects and landscape architects, which finally resulted in cooperation. They started to consider the possibility of application of vertical gardens in cities and inside buildings. The project carried out with Jean Nouvel or Jacques Herzog and Pierre de Meuron, bound permanently Blanc's activity with architecture [1]. Looking at such works like: Musee Du Quai Branly in Paris (2005) or Caixa Forum Museum in Madrid (2006), the saying of Frank Lloyd Wright that "a doctor can bury his mistakes, but an architect can only advise his clients to plant vines" [8] seems to be no longer valid.

Nowadays, plants are becoming a rightful façade material creating the architecture; their usage is planned and dedicated to achieve both a particular aesthetic and ecological effect. Urban landscape enriched with the vertical garden gains an additional biologically active surface, which increases its biodiversity. One can say that plants become a part of a building, but at the same time the building becomes a part of the ecosystem. An important feature of the vertical garden, especially significant for urban areas, is its ability to grow in already built up places, where there is no room for traditionally shaped greenery. The process of densifying building area concerns all agglomerations. Systems of public greenery designed mostly at the turn of the nineteenth century (inspired by such ideas as City Beautiful Movement and Garden Cities) and in the mid-twentieth century appear to be insufficient to serve twenty-first century cities. Thanks to vertical gardens it is possible to fix the systems of urban greenery made of traditional elements such as: alleys of trees, hedge, square, park, urban garden, green roof, which have to be continuous in order to work properly. The establishing cost and energy intensity of vertical gardens are relatively high and their maintenance is complicated in the



case of walls that exceeds 3m high; if coupled with an urban greenery system, they give such benefits as improvement of the city ventilation system, reduction of the heat island and increase the biodiversity.

The research on the potential influence of vertical gardens on air quality were conducted in Great Britain while creating the green wall near the Edgware Road underground station. Earlier studies showed that air pollution is deposited more easily onto plants than hard surfaces. Tom Pugh and his colleagues at Lancaster University created a model showing that green walls are particularly effective in the process of reducing such pollution as  $\text{NO}_2$  and particulate matter  $\text{PM}_{10}$ , in streets where both sides are lined continuously with buildings and where the air circulation is limited. In such cases the pollution may be deposited on the green walls for a longer time. According to research, it is possible to reduce air pollution to as much as 40% for nitrogen dioxide and 60% for  $\text{PM}_{10}$  dust. The results of the analysis may vary depending on the street's layout, wind speed and the degree of wall covering with plants. Linda Davies presents a more careful approach to the above-mentioned results pointing out that the research was not tested in practice. Davies investigating the effect of green walls has selected plants with small hairy leaves which are best at absorbing  $\text{PM}_{10}$  [5, 6].

The building of the Foundation for Polish science in Warsaw, designed by FAAB studio is an example of implementation of a green wall in polish environment. It has been refurbished and adapted to a new function. It has also been designed and constructed in accordance to ecological standards. The building is equipped with heat pumps, rainwater tank and a 260 m<sup>2</sup> green wall double facade situated to the north and south. According to the designers idea, the green facade is supposed to aid air-conditioning systems. To protect plants from extreme temperatures which are typical for Poland and to prevent roots from freezing and falling off, a thicker layer of insulating material has been introduced for the plant roots. 20 species of plants have been selected for the design, however the authors point out that the form of the wall will change in time. The species will have to be tested in situ. Some of them may not be suitable for the polish climate and therefore, they will have to be replaced. The increase in biodiversity is inevitable due to seeds being transferred by the wind and birds. The green wall has an automatic irrigation system installed [7, 9].

The project was completed in 2013, so the evaluation of the designers' ideas is not yet available. Several questions arise such as: Is the energy gain which comes from the introduction of a double facade enough to compensate the use of water and electricity that is necessary for the irrigation system?

#### 4. Conclusions

Much research shows that vertical gardens confirm their great usefulness in a city and have big and positive environmental effect. Systematic introduction of vertical gardens into cities seems to be justified and is the right solution for implementing greenery in places where it is necessary because of the low quality of the environment and difficulty of current land use. S. Herrington says that: '(...) landscapes are spaces that condition and are conditioned by cultural and natural systems directly connected to our well-being' [3]. It means that the spread of vertical gardens and green roofs in urban areas is an indication of the concern of humans about ecology, as well as the high quality of the cultural landscape.

## References

- [1] Blanc P., *The Vertical Garden. From nature to the city. Revised and updated*, W. W. Norton and Company, New York–London 2011, 90-100.
- [2] Blanc P., Vertical Garden Interview in Paris 2007 [http://www.youtube.com/watch?feature=player\\_embedded&v=63D2UkkTtBQ](http://www.youtube.com/watch?feature=player_embedded&v=63D2UkkTtBQ); access: 04.07.2013.
- [3] Herrington S., *On Landscapes (Thinking in Action)*, Routledge, Issue 1, New York 2009, 14.
- [4] Kosiński W., *Pionowe ogrody- idea, technologia i estetyka na nowy wiek*, [in:] Technical Transactions, 2-A/2/2011, Wydawnictwo Politechniki Krakowskiej, Cracow 2011, 106-109
- [5] Pugh T.A.M., MacKenzie A.R., Whyatt J.D., Hewitt C.N., *Effectiveness of Green Infrastructure for Improvement of Air Quality in Urban Street Canyons*, [in:] Environmental Science & Technology, ACS Publications 2012, 7692; <http://greenroofs.org/resources/GreenInfrastructurePaper.pdf>; access: 06.07.2013.
- [6] *Green walls could dramatically reduce air pollution, study shows*, [in:] ENDS (Environmental Data Services), Issue 450, Haymarket Business Publications Ltd., 2012, 20; <http://www.biblos.pk.edu.pl/>; access: 01.07.2013.
- [7] [http://architektura.muratorplus.pl/realizacje/nawosci/zielona-sciana-warszawskiego-biurowca\\_80938.html?&photo=69575#gallery](http://architektura.muratorplus.pl/realizacje/nawosci/zielona-sciana-warszawskiego-biurowca_80938.html?&photo=69575#gallery); access: 07.07.2013.
- [8] [http://www.brainyquote.com/quotes/authors/f/frank\\_lloyd\\_wright.html](http://www.brainyquote.com/quotes/authors/f/frank_lloyd_wright.html), access: 07.07.2013.
- [9] [http://faab.pl/projekty/siedziba\\_fundacja\\_na\\_rzecz\\_nauki\\_polskiej\\_k2\\_131.html](http://faab.pl/projekty/siedziba_fundacja_na_rzecz_nauki_polskiej_k2_131.html); access: 07.07.2013
- [10] <http://www.verticalgardendesign.com/how-it-works>; access: 05.07.2013.





ALINA DRAPELLA-HERMANSDORFER\*

## THE LANDSCAPE PLAN FOR THE ŚLĘŻA RIVER PARK IN WROCLAW: NEW ORGANIZATIONAL AND TECHNICAL SOLUTIONS

### PLAN KRAJOBRAZOWY PARKU ŚLĘŻY WE WROCLAWIU: NOWE ROZWIĄZANIA ORGANIZACYJNE I TECHNICZNE

#### Abstract

The paper contains an introduction to the principles of landscape planning and presents the benefits of establishing a linear Ślęza River Park. It is one of five river parks that may be created in flooded areas in Wrocław, forming the core of the Green Infrastructure system. The adopted form of the landscape plan refers to similar studies from Germany, the Netherlands and the UK. In Polish conditions, the plan has an innovative character and enables the implementation of a number of technical and organizational solutions, leading to a more synergetic use of environmental resources in the belt of riverside areas. The program of the management of the park and the related tourist trail refers to the history of Western Slavs, called Slezane, who inhabited the basin of Ślęza in the early Middle Ages. Along the river there are many archaeological sites from this period and the route Wrocław with the massif of mount Ślęza – the holy place of ancient worship in Silesia.

*Keywords: Green Infrastructure, landscape plan, Wrocław*

#### Streszczenie

Artykuł przedstawia metodę opracowania oraz korzyści wynikające z utworzenia linearnego Parku Ślęzy. Jest on jednym z pięciu parków rzecznych, które mogą powstać na terenach zalewowych Wrocławia, tworząc rdzeń systemu Zielonej Infrastruktury miasta. Przyjęta forma planu krajobrazowego nawiązuje do analogicznych opracowań z terenu Niemiec, Holandii i Wielkiej Brytanii. W warunkach polskich ma ona charakter nowatorski i ułatwia wprowadzenie szeregu rozwiązań technicznych i organizacyjnych, prowadzących do bardziej synergicznego wykorzystania zasobów środowiska przyrodniczego w pasie terenów nadrzecznych. Program zagospodarowania parku i szlaku turystycznego nawiązuje do historii Ślęzy, wzdłuż której rozwinęła się historia Słowian Zachodnich, zwanych Ślężanami. Znajduje się tu wiele stanowisk archeologicznych z tego okresu, a sam szlak wzdłuż rzeki łączy teren współczesnego Wrocławia z masywem Ślęży – świętej góry Śląska.

*Słowa kluczowe: Zielona Infrastruktura, plan krajobrazowy, Wrocław*

\* Prof. D.Sc. Ph.D. Arch. Eng. Alina Drapella-Hermansdorfer, Faculty of Architecture, Wrocław University of Technology.

## 1. Introduction

The riverside green belts combined with public spaces, greenways and boulevards, sometimes referred to as river parks, are becoming a common feature of our cityscapes and almost as important for their identity as complexes of historical architecture. They can be found in London (Brent River Park), Madrid (Manzanares River linear park) and Berlin (Spreepark). The first river park system in Poland was formulated in the years 1996–1997, in the master development plan of the city of Cracow and has been implemented there ever since [1]. Eleven years later, a programme called the Szczecin Floating Garden 2050 was created as a long-term vision of urban development at a lagoon in the Odra/Oder estuary. The question arises: whether river parks can be recognised as a step towards a sustainable city concept just like sustainable transport or energy efficient management?

In Wrocław, the idea of establishing a linear park along the Odra was developed at the Faculty of Architecture of the Wrocław University of Technology (WrUT) in 1992 [2]. It was not taken into account in official planning documents, although the river valleys were identified as areas of special importance in the first study of spatial development conditions and directions of the city from 1997. The aim of the Blue Strategy of Wrocław (BSW), which is presented in this article with regard to the conception of the Ślęza River Park, is to facilitate the development of the urban green infrastructure system.

## 2. Ecological corridors as a part of Wrocław's natural and cultural heritage

The early medieval identity of the Silesia region was linked with the Ślęza River. The name of this right-bank tributary of the Odra gave origins to the names of the Slavic tribes that settled here (*Sleenzane*) and their holy mountain called Ślęza, which rises in the middle of a vast lowland, about 50 km south of Wrocław. Calm waters and fertile soils had created favourable conditions for the settlement; however, after the 10th century, the nucleus of the future city was formed on the islands near the main crossing of the Odra. The mouth of Ślęza, situated a few kilometres west of the ford, protected one part of the city, while the access to the eastern section was limited by Oława, which has supplied the city moats with water from the 12th century. The northern zone of protection was delineated by the Widawa River, which today forms part of Wrocław's boundaries.

The rivers shared characteristic lowland watercourses; they formed new arms after floods, frequently changing the shape of the river bed and posing a threat to nearby inhabitants. For this reason, people were settling at a safe distance from the water, which flowed in a wide corridor between meadows and forests that strengthened its banks. The palaces constituted a derogation from this principle, due to the parks and their necessity of access to water. A majority of parks in the present-day Wrocław were established outside its boundaries in the vicinity of the rivers.

A well-developed network of riverside green corridors is best visible in the Wrocław city development plan (1924–1925), supervised by Fritz Behrendt, who regarded the Ślęza as an axis for locating garden housing estates (Ill. 1). He left a wide belt along the Odra free from any development, especially upstream, where he allowed the river to flood the nearby areas in order to protect the city. The inflow point of the Ślęza into the Odra (where the modern-

day Kozańów housing estate is situated) provided additional flood protection, similar to the Widawa River valley, which is used as a sort of a relief canal for the Odra. None of the later plans reflect such an in-depth understanding of the role of the rivers. Behrendt's plan assumed the construction of two new ports, which were to serve the industrial zones to be developed along both banks of the Odra. Together with the city port, established in 1897, and two river shipyards, they formed a dense waterway infrastructure, located some distance from the city centre. Two hydropower stations, erected under Max Berg in the years 1924–1925, created the only interference with the old cityscape.



III. 1. The view from the proposed Śleza River Park and the community Mammoth Park with a sculpture by Tadeusz Teller (photo by the author)

Behrendt's plan set out the main directions, which were followed until the mid-1940s [5]. After WWII, the transport operations on the Odra Waterway resumed and further developed until the post-1989 socioeconomic transformations, when the river navigation collapsed and numerous navigation-related facilities were closed down [3]. It is expected that the modernization of the Wrocław Water Junction in the years 2009–2015 will improve the situation. Constituting part of the Odra Catchment Area Flood Protection Programme (POPDO), it focuses on improving the flood protection facilities and adapting the existing water engineering facilities to the requirements of a class III waterway. However, it does not provide for any accompanying capital investment projects aimed at their multi-purpose use in line with sustainable development principles. As a result, Behrendt's vision is still awaiting its creative continuation.



### 3. The Blue Strategy of Wrocław

Since 1993, the Section for Environmental Planning of the Faculty of Architecture of WrUT has been carrying out numerous research and educational programmes, engaging in a type of a dialogue with the planning solutions related to the Odra and other rivers proposed by the city authorities. The BSW constitutes an attempt at gathering all such reflections into an integrated package of projects and designs, inspired by the corresponding documents drawn up for London (“The Blue Ribbon Network”), Lille (“Trame Bleue”) or Madrid (“Madrid Rio”). The strategy aims to establish a network of green infrastructure along the Odra and its tributaries: Oława, Ślęza, Bystrzyca and Widawa – as a core integrating Wrocław’s present-day landscapes into a new cultural entity. An important role is assigned to ‘the river’s tales’ about the history of the site and its inhabitants, to make them part of the city’s mission to become a meeting place.

1. As a chain of ‘**meeting places with nature**’, the valleys combine the *Natura 2000* sites with a number of other areas with the highest natural values, presenting the typical forests, plants and animals of Lower Silesia. However, despite of their riverside location, currently these places are neither connected to each other nor properly prepared for public use. From this point of view, the planned actions aimed at mitigating climate change should concentrate on strengthening and expanding the ecological corridors and greenways along the rivers. This means, for instance: additional plantings of local trees, restoration of the selected old river beds or turning of some areas into eco-parks (e.g., irrigation fields removed from service).

2. As a network of ‘**meeting places with economy**’, the blue infrastructure forms a kind of an eco-museum [4], which emphasizes the role of science and technology in the city life, combining such significant issues as the use of the rivers for transport, energy and water management. The last point has a particular importance in the context of flood control and climate change mitigation. This should be understood as the adoption of new urban standards linked with the so-called water sensitive urban design (wsud), which is aimed at using rainwater near the point of precipitation in variously shaped biologically active areas. This way of re-naturalization of the urban environment is related to the introduction of green infrastructure as supplementing or replacing traditional rain water drainage. The rivers and riversides constitute the terminal areas in the systems of water capture, storage, phytomelioration and infiltration sites. The main wsud objective is to minimise the impacts of rainwater on the built environment by mimicking the natural water cycle as closely as possible. The adoption of the new standards of floodplains management becomes very important in the light of the changes in spatial policy, caused by the implementation of the Water and Flood Directives.

Simultaneously, a special place should be provided for various forms of urban agriculture that can be found in the riverside ecological corridors. Their development requires appropriate organizational support and a peculiar landscape reinterpretation, along the lines followed by Vienna, Berlin or Milan.

3. As a set of ‘**meeting places with people**’, the blue network should be regarded as the core of a new system of public spaces, encompassing beaches, parks, sports-and-recreational infrastructure, agricultural land and a multitude of water engineering facilities located along the rivers. In practice, this translates into the need to formulate new standards relating to the development of floodbanks, inter-embankment zones and floodplains with a view to:

- ensuring the continuity, attractiveness and safety of pedestrian and bicycle paths running along the banks (the issue of separated underpasses under bridges),
- preparing a visual identification system based on the tradition of the site,
- formulating an organizational and legal framework to support the civic initiatives related to the implementation of BSW.

According to these principles, the emerald network is to perform ecological, economic and social (including cultural) functions. In the case of the design work done by the Section for Environmental Planning, special attention is paid to understanding the ‘spirit of the place’ and creative interpretation. Despite many similarities, Wrocław’s rivers are fairly varied in nature. Identification studies are thus intended to determine further development directions for waterside areas, which can be recognized in the context of the history of the areas along the Odra River and their inhabitants since time immemorial (Ill. 2).

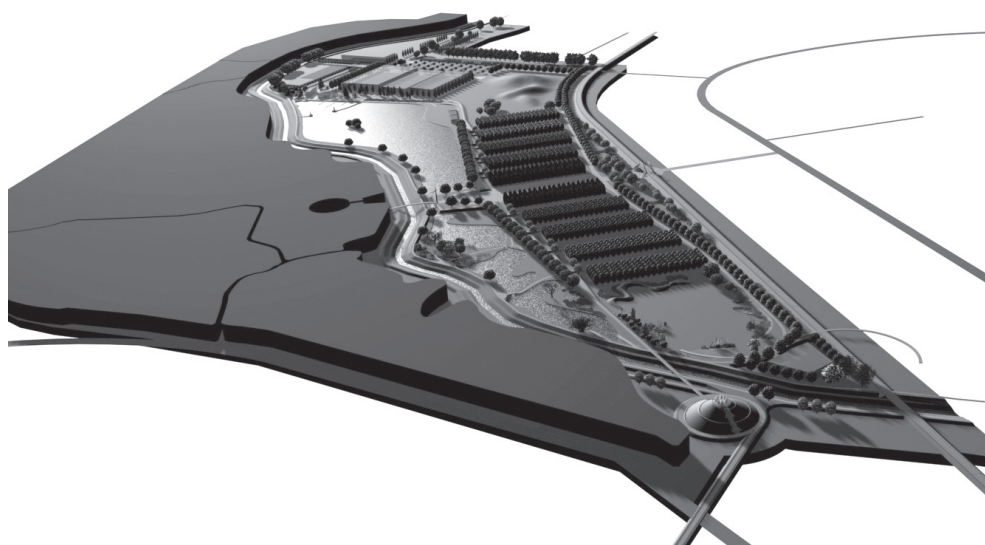

Ill. 2. Millennium Park – the main landmark of a commemorative importance along the Ślęza River: the initial concept from 2000 (currently under construction). The authors: Alina Drapella Hermansdorfer, Teresa Lorenc, Ryszard Majewicz, Paweł Ogielski et al. Graphic layout by Piotr Asfeld

#### 4. The place of the Ślęza River Park in the Blue Strategy of Wrocław

In terms of BSW, the river’s tales were differentiated according to the tradition of the place and the current features of the site. This kind of interpretation can pay attention to the rich natural and cultural heritage of the city where:

- inaccessible overflow areas of the Oława River in water-bearing areas are interpreted as remains of primary wildscapes,
- the belt of archeological sites along the Ślęza River and a potential tourist route linking Wrocław with the Ślęza Mountain alludes to the early settlement and formation of Silesia’s cultural identity,

- the belt of parks, palaces and mills along the Bystrzyca River reflects the period at the top of the development of agrarian culture in these areas (at the turn of the 19th century),
- vast meadows on the Widawa combined with an eco-park in the irrigation fields are a testament to a new era in the city's history, oriented towards sustainable development.

In this narrative concept, the Odra, as a river linking all historical periods, performs a role corresponding to the time axis and is best equipped with various elements of natural, transport, social, etc. infrastructure. In determining the boundaries of the Ślęza River Park, the Landscape Character Assessment (LCA) method has been applied [6] and has been used by the Institute of Landscape Architecture of the Faculty of Architecture of Cracow University of Technology since 1970s [9].

The landscape plan of the Ślęza River Park is an example of such a method of study. It was elaborated during classes with second-year students of Bachelor of Science (BSc) in Spatial Planning and Management Programme at WrUT [7].

### Karta Inwentaryzacji Krajobrazowej

Obszar: Teren zieleni spontanicznej przy rzece  
Data: 11 stycznia 2013  
Nr jednostki: 11NZs  
Nr Zdjęcia: 9, 10  
Kilometraż: Od 6+100 do 7+600

#### Kierunek Widoku:

- 9 - widok na teren jednostki
- 10 - widok na teren jednostki

Rys. 1 - Mapa Historyczna Rys. 2 - Kierunki - Ochrona i Kształtowanie Środowiska Rys. 3 Uwarunkowania - Przaszaczenie i Zagospodarowanie



#### Elementy dominujące w krajobrazie:

##### Zabudowa Mieszaniowa:

Brak zabudowy

##### Obiekty Inżynijne:

Jednostka przylega do jednostki rzecznej, w której występują wały rzeczne oraz progi wodne.

Jednostka przylega do linii kolejowej

##### Komunikacja:

Ścieżki pieszo rowerowe

##### Woda:

Brak

Jednostka znajduje się w bezpośrednim kontakcie z jednostką rzeczną

##### Zieleń:

Ogródki działkowe

#### Typ krajobrazu

Jednostka o charakterze nizinnym znajdująca się w bezpośrednim kontakcie z rzeką Ślężą. Jest to duży teren zieleni niezagospodarowanej.

Ill. 3. Landscape Character Assessment of the unit "11NZs": a part of a typical inventory card, containing elements of the historical and visual analysis [7]

The study area (approximately 900 acres of emerald network) has been divided into 84 landscape units, homogeneous in terms of topography and land cover (Ill. 3). The students worked in three teams of 4-5 people and each group examined a section with a length of circa 6 km, since the total length of the river in the city is 17.5 km. The research focused on the green belts situated along the Ślęza River and in their direct vicinity, taking into consideration the mutual relationship between them. It was estimated that the nearest areas are inhabited by over 60 thousand residents (about 10 percent of Wrocław's population) and

it should be emphasized that these districts have the lowest ratio of open space to built-up areas in the city. The examination also covered the planning intentions related to the areas in question contained in the 2010 Study of Spatial Development Conditions and Directions of Wrocław [10].

For each unit a separate inventory card was prepared (reviewing the various analytical aspects) and then subjected to various assessments aimed at establishing the optimum development option (protection and continuation of the current function or its transformation). This led to the creation of a rich database, which can be used for various purposes and the conceptual options proposed by individual groups are a source of inspiration for a civic discussion about changes in the next version of the Study. After completion of the analysis, each team presented its own concept of development of the entire area (Ill. 4). The concepts were supposed to include all the previously discussed ‘meeting places’ following the principles of sustainability.



Ill. 4. The main areas of the Ślęza River Park as the elements of “emerald network” designated to the further development and connection by a system of biking and foot paths. Legend: 1) The hippodrome in the Partynice, 2) The Grabiszynski Park and planned community Mammoth Park, 3) The Millennium Park, 4) the Pilczycki Forest: a Special Area of Conservation (SAC) within the Natura 2000 network [7]. Graphic layout by Grzegorz Kasza



#### 4. Conclusions

The concept of the Blue Strategy of Wrocław is aimed at initiating a public debate on the cityscape identity. The lack of such a vision is conducive to the implementation of accidental capital investment projects at attractive locations near the rivers, which in the future can significantly hinder access by the public to open areas which form a historical legacy of the many generations that have lived here before us. In addition, the obligation to draw up our own landscape policy and to determine the so-called landscape quality objectives arises from the European Landscape Convention signed by Poland in 2004. At a time when a significant number of European cities are implementing their own green infrastructure development plans, this is still a notion largely unknown in Poland, which is neither reflected in legislation nor specialized vocabulary, just like the notion of water sensitive urban design. The preparation of young people for performing such tasks in sustainable development categories and their inclusion in the preparation of a civic discourse was one of the goals of the Ślęza River Park landscape plan that has been presented here.

#### References

- [1] Böhm A., *Parki rzeczne w krajobrazie Krakowa/River parks in Cracow*, Architektura Krajobrazu, No. 2-3, 2001, 17-22.
- [2] Drapella-Hermansdorfer A., *Wrocławskie konfrontacje z rzeką. Koncepcja parku Odry*, [w:] *Miasto tyłem do rzeki* (Wierzbicka B. red.), Towarzystwo Opieki nad Zabytkami, Warszawa 1996, 50-61.
- [3] Drapella-Hermansdorfer A., Lorenc M., Masztalski R., Świerkosz K., Wojtyszyn B., *Wrocławska Odra – nurt życiodajny i śmiercionośny*, Rocznik Wrocławski XIII, Z. 4. Towarzystwo Przyjaciół Ossolineum, Wrocław 1997, 37-80.
- [4] Januszewski S., *Otwarte Muzeum Techniki*, [in:] *Wrocław a Odra*, Urząd Miejski Wrocławia, Biuro Rozwoju Wrocławia, Wrocław 1999, 251-261.
- [5] Kononowicz W., *Wrocław. Kierunki rozwoju urbanistycznego w okresie międzywojennym*, Oficyna Wydawnicza PWr, Wrocław 1997.
- [6] *Landscape Character Assessment. Guidance for England and Scotland* (by C. Swanwick and Land Use Consultants) The Countryside Agency & Scottish Natural Heritage 2002.
- [7] *The Landscape Plan of the Ślęza River Park in Wrocław*, The students teamwork supervised by Alina Drapella-Hermansdorfer; Bachelor (BSc) in Spatial Planning and Management Programme, Wrocław University of Technology, Faculty of Architecture, Wrocław 2013.
- [8] *The London rivers Action Plan. A tool to help restore rivers for people and nature*, The River Restoration Centre, Cranfield University, Cranfield 2009.
- [9] *Ochrona wartości krajobrazu i środowiska kulturowego w stadium do planu i miejscowym planie zagospodarowania przestrzennego*, Krajobrazy 18/30, Ośrodek Ochrony Zabytkowego Krajobrazu, Warszawa 1998.
- [10] *Studium uwarunkowań i kierunków zagospodarowania przestrzennego Wrocławia*, Biuletyn Urzędowy RMW z 31 maja 2010 r., Nr 5, poz. 116.

SABINA KUC\*

## TECHNOLOGIES AND INNOVATIONS AT THE IBA AND IGS EXHIBITIONS – HAMBURG 2013

### TECHNOLOGIE I INNOWACJE NA WYSTAWACH IBA I IGS – HAMBURG 2013

#### Abstract

Hamburg has become a world-class innovation centre indicating the direction of ecological transformations in the 21<sup>st</sup> century. Internationale Bauausstellung (International Building Exhibition) IBA Hamburg 2006–2013 is a rebuilding process unfolding over many years and being an answer to the question about the architectural future of cities; it is a place where the latest achievements of building technology and designs of the architecture of the future are presented. Internationale Gartenscha (International Garden Show) IGS Hamburg 2013 offers a new municipal park in Wilhelmsburg to its inhabitants, where they can find leisure, recreation and educational grounds. Modern residences, office buildings and shops were built on the edges of the park within the IBA. The whole creates a harmonious green space defining a new quality of living. These enterprises show how to transform a neglected urban space in a sustainable manner so that it is both attractive for people and environmentally-friendly.

*Keywords: architecture, landscape architecture, building technologies, IBA Hamburg, IGS Hamburg, IGA, BUGA, LAGA*

#### Streszczenie

Hamburg stał się światowej klasy centrum innowacji, wyznaczającym kierunek ekologicznych przemian w XXI wieku. Internationale Bauausstellung (Międzynarodowa Wystawa Budowlana) IBA Hamburg 2006–2013 to proces odbudowy rozłożony na lata, będący odpowiedzią na pytanie o architektoniczną przyszłość miast, to miejsce, gdzie prezentowane są najnowsze osiągnięcia technologii budowlanej i projekty architektury przyszłości. Internationale Gartenschau (Międzynarodowa Wystawa Ogrodowa) IGS Hamburg 2013 oferuje mieszkańcom Hamburga nowy park miejski w Wilhelmsburgu. W parku można znaleźć tereny do wypoczynku, rekreacji i edukacji. Na obrzeżach parku w ramach IBA powstały nowoczesne rezydencje mieszkalne, biurowce i sklepy. Całość tworzy harmonijną zieloną przestrzeń, wyznaczającą nową jakość życia. Przedsięwzięcia pokazują, jak można w sposób zrównoważony przekształcać zaniedbaną przestrzeń miejską tak, aby była atrakcyjna dla ludzi, a zarazem przyjazna środowisku.

*Słowa kluczowe: architektura, architektura krajobrazu, technologie budowlane, IBA Hamburg, IGS Hamburg, IGA, BUGA, LAGA*

\* Ph.D. D.Sc. Eng. Arch. Sabina Kuc, Faculty of Architecture, Cracow University of Technology.

## 1. Introduction

New technologies and innovations connected with their application are currently being broadly discussed in both scientific and popular publishing. Presentation of their implementations in architecture frequently takes place in competitions, exhibitions, biennials etc.

The idea of presenting innovations and new technologies in international or regional exhibitions dates back to the mid-eighteenth century, although it was the Great Exhibition in London from 1851 which was recognized as the first truly global exhibition. Presentation of cultural, scientific and technical heritage lies at the basis of these cyclically organized international events. They also offered an opportunity for a competition in a given field among the participants. One can observe the striving to raise the level of presentation and the impetus of accompanying events every year. Regional exhibitions are governed by the same ideas, but the scope of the impact is smaller.

A perfect example of the above mentioned presentations are the German International Building Exhibition (Internationale Bauausstellung IBA) and the International Garden Exhibition (Internationale Gartenbauausstellung IGA) and also the National Garden Exhibition (Bundesgartenschau BUGA) or a smaller exhibition in a particular area (Landesgartenschau LAGA).

## 2. The IBA idea and history

The history of building exhibitions begins in the early twentieth century, when the first exhibitions in Darmstadt Malthildenhöhe (1901, 1908, 1914) and Leipzig (1913) presented the latest trends in architecture. Later, the implementations of architectural concepts on a global scale in Stuttgart (1927) and Brno (1929) and urban planning ideas in Vienna (1932) and West Berlin (1957) appeared in the history of shows. 1979 turned out to be a breakthrough year when Internationale Bauausstellung (IBA) Berlin GmbH programme including the works of Peter Eisenman, Zaha Hadid, Rem Koolhaas, Paul Josef Kleihues, Rob Krier, Aldo Rossi, Wolf Siedler, James Sterling and Elia Zanghelis were introduced. The IBA exhibition in Berlin was opened in 1987. It achieved a tremendous success by signing up permanently on the architectural map of Europe. The following exhibitions were IBA Emscher Park in 1989–1999, IBA Fürst-Pückler in 2000–2010 and IBA Stadtumbau Sachsen-Anhalt in 2002–2010. The latest being IBA 2006–2013 in Hamburg.

## 3. BUGA and IGA garden shows' idea and history

Presentations of the latest trends in landscape architecture are architectural, horticultural and landscape undertakings. Various examples of compositing plants, from simple gardens to large expansive parks, and related technical innovations in the field of technology, construction, installation and materials are presented depending on the event's profile. Among the presented objects, there appears, as defined by Amanda Marshall in the Venice Biennale's catalogue, „a beautiful landscape [...] congruent with the twenty-first century and

a)



b)



III. 1. IBA Hamburg 2013, CITIES AND CLIMATE CHANGE, IBA DOCK: a) IBA DOCK view from the waterfront, b) IBA DOCK interior with centrally located Hamburg map and marked IBA and IGS 2013 buildings (photo by S. Kuc)



III. 2. IBA Hamburg 2013, CITIES AND CLIMATE CHANGE, Georgswerder Energy Hill (photo by S. Kuc)

a)



b)



III. 3. IBA Hamburg 2013, METROZONES: a) Wilhelmsburg Urban Railway Station and Pedestrian Bridge, b) New Ministry of Urban Development and the Environment (photo by S. Kuc)



inhabited by the symbols of the twenty-first century”. It’s mostly about concepts beyond the old technical barriers and providing new insights on the formation of the contemporary landscape.

German landscape architects can confront their creative visions during multiple landscape architecture events. The most important and having the longest tradition at the same time is BUGA (Bundesgartenschau). The National Garden Exhibition is an event reflecting wide coverage in the environment of creators and supporters of landscape architecture. Organized every two years, BUGA was recently held in Magdeburg (1999), Potsdam (2001), Munich (2005), Gera and Ronneburg (2007), Schwerin (2009), Koblenz (2011) and international exhibition IGS in Rostock (2003) and Hamburg (2013). As in the case of building exhibitions they also have a high social impact. Every time, they leave behind a modern developed area: green space, municipal park or larger landscape design that will serve residents on a daily basis even after the exhibition’s displays have disappeared [2].

#### **4. Technologies and innovations**

Between 2006–2013, aided by the IBA, Hamburg began the reconstruction process unfolding over the years, which is a response to the question about the architectural future of cities. Thus, it became a world-class innovation centre indicating the direction of ecological transformations in the construction industry, holistically treating urban, architectural, infrastructure and environmental science issues [3, 4, 6].

Simultaneously, IGS 2013 offered a new municipal park to Hamburg residents in Wilhelmsburg where they can find leisure, recreation and education grounds. Modern residences, office buildings and shops were built on the edges of the park within the IBA. The whole creates a harmonious green space defining a new quality of living. These enterprises show how to transform a neglected and degraded urban space in a sustainable manner so that it is both aesthetically and functionally attractive and environmentally-friendly.

The buildings of the IBA Hamburg are laboratory-like. The purpose of the project was to indicate the direction of future energy-efficient district development, where:

- the cost of construction could not to exceed the average cost of construction per square meter in the district (buildings after the IBA exhibition are to be sold on the primary market),
- protection against flooding will be ensured,
- high energy efficiency of the building and district (zero energy buildings, virtual power plant) will be guaranteed,
- the buildings will force residents to take action to protect the environment, such as reducing the amount of waste, reduction of car trips etc.

All the buildings are characterized by innovative architecture and construction solutions, and are zero-energy (total heat demand is less than 35 kWh/m<sup>2</sup>). The surplus energy produced by buildings shall be transmitted to the network and the so called virtual power plant: interconnected units. An essential element of this district structure is the heat reservoir in a converted bunker from the time of World War II (Energiebunker). It houses a buffer storage facility with a total capacity of 2000 m<sup>3</sup> heated by surplus energy produced by prosumers including the one coming from its own renewable energy sources. The possibility of energy

a)



b)



III. 4. IBA Hamburg 2013, METROZONES: a) Water Houses, Living at the Wilhelmsburg Island Park, b) Natural, efficient and innovative: The Smart Material House (photo by S. Kuc)

a)



b)



III. 5. IGS Hamburg 2013: a) Flags with exhibition advertisement, b) World of Ports (photo by S. Kuc)

a)



b)

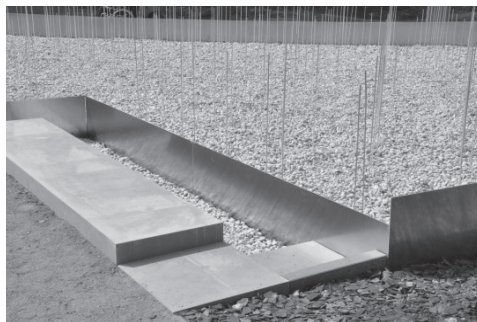

III. 6. IGS Hamburg 2013: a) World of Water, b) World of Continents (photo by S. Kuc)

storage allows for the flexibility of reception, depending on the final consumer demand. A significant element of the district's energy supply is the Energy Hill (Energieberg), a producer of methane and wind energy in the former Deponie Georgswerder landfill. Solar panels and windmills on the former landfill provide electricity for 4 thousand flats. The district is not only self-sufficient in energy, but it also earns money from the introduction of electricity to the grid. With the profits it covers the cost of waste water treatment and local public transport [3].

Within the IBA project, many interesting in terms of engineering, intelligent and green public and residential buildings were constructed. Residential buildings are hybrid, in which the function of the rooms can vary depending on the needs, as the installations and technical equipment are distributed in a way that allows for flexible modifications.

The most important examples include [4, 6]:

- a building complex of the Ministry of Urban Development and the Environment, in which below its green areas, there is a reservoir storing geothermal heat and heat from the solar panels of the building,
- Smart It's Ground, a five-storey residential building with phase-change (PCM) materials on the facade which significantly affect thermal comfort by storing heat during the day and giving it off at night,
- SOFT Mouse residential building, characterized by a mobile (dynamic) facade, built of modules containing photovoltaic cells and membranes which react to sunlight (the intelligent, possible to be controlled by the inhabitants, façade provides heat loss reduction and deep solar radiation penetration to the inside of the building depending on the needs of the shading of the building), minimizing heat loss and allowing deep penetration inside by solar radiation,
- BIQ Wilhelmsburg Mitte, a prototype residential building, the glass facades of which produce energy with bioreactors.

The latter is the most spectacular example of the modern concept of the building using renewable energy sources. The budget of 4,500,000 EUR resulted in the project designed to demonstrate the viability of bio and eco-friendly building construction. It is the first inhabited building in the world to have a bioreactor façade. The glass facade panels were inoculated with cultures of unicellular algae (phytoplankton). Constant nutrients are supplied in the form of diluted waste water and carbon dioxide by a separate water circuit. The algae flourish and multiply in a regular cycle until they can be harvested. They are then separated from the rest of the algae and transferred as a thick pulp to the technical room of the BIQ. Afterwards they can be fermented in an external biogas plant and thus re-used for the generation of biogas. Algae are especially well-suited to this process because, compared with soil-grown plants, they produce up to five times as much biomass per hectare. Apart from the production of energy, wall panels can control the natural lighting and isolate the interior of the building. Moreover, the façade collects energy by absorbing the light that is not used by the algae and generating heat, which is then either used directly for hot water and heating, or can be cached in the ground using borehole heat exchangers: 80 metre-deep holes filled with brine.

From an architectural point of view, it is also interesting that the BIQ not only draws all the energy needed for the production of electricity and heat from renewable sources, but also the inhabitants of the fifteen flats located in the building can configure the internal space of the apartment adjusting functional layout to suit their needs.



III. 7. IGS Hamburg 2013, World of Cultural Diversity (photo by S. Kuc)

a)



b)



III. 8. IGS Hamburg 2013, World of Activity: a) Climbing Hall, b) Skate Park (photo by S. Kuc)

## 5. Conclusions

The relationship between energy and modern construction and architecture is an issue more and more often discussed with regard to the economic and environmental aspects, current technical knowledge and the requirements relating to the design of energy-efficient buildings.

Both IBA and IGA exhibitions in Hamburg, which embraced most of the city, confirmed the desirability of a multisite architectural, urban planning and engineering action. After analysing the overall problems of the city, the recovery program was presented and later implemented in between 2007 and 2013. An architectural and landscape “organism”, was created, which due to the latest technologies and innovative solutions, is to create a friendly, sustainable living environment for the residents. Thus, Hamburg has been recognized as a world-class innovation centre and has become a world-class innovation centre indicating the direction of urban ecological solutions in the 21<sup>st</sup> century.

Building and garden exhibitions are not only a form of presenting the latest developments in the field of architecture, urban planning and landscape design but also the instrument of urban planning and urban design in a specific location, closely associated with that place, which may become a model and an inspiration for other works.

## References

- [1] Celadyn W., *Energia w architekturze*, Kwartalnik Architektury i Urbanistyki: teoria i historia (*Energy in architecture*, Architecture and Urban Planning Quarterly: Theory and History), Państwowe Wydawnictwo Naukowe, Vol. 57, No. 3, 2012, 36-56.
- [2] Drapella-Hermansdorfer A., *Bilans końca wieku*, Architektura Krajobrazu, 1/2001, 4-33.
- [3] *Energy Atlas, Future Konzept, Renewable Wilhelmsburg*, Jovis Verlag GmbH, Berlin 2012.
- [4] *IBA Hamburg, Project and Concepts, Catalogue for the Interim Presentation 2010*, Jovis Verlag GmbH und IBA Hamburg GmbH, 2011.
- [5] Jaworska-Michałowska M., *Środowisko zbudowane włączone do ekosystemu. Wybrane problemy* (*The built environment included in the ecosystem. Selected problems, Journal of Technical Science*), Czasopismo Techniczne, 4-A/2007.
- [6] *Towards a New City, A Guide to the Elbe Islands and the Project of the IBA Hamburg*, tekst Ainer Muller, Internationale Bauausstellung Hamburg GmbH, 2012.



LIUDMILA RUBAN\*

## THREE STATES OF WATER: HOW TECHNOLOGY MAKES “WATER” A CONSTRUCTION MATERIAL

---

### ZASTOSOWANIE WODY W ARCHITEKTURZE WSPÓŁCZESNEJ: NOWE PODEJŚCIE DO MODELOWANIA PRZESTRZENI

#### Abstract

Analysing European buildings, the author notices a new approach to the use of water in contemporary architecture and landscape practice. The modern experience of space modelling with three states of water (solid, liquid and vapour) extends the concept of “architecture of water” incorporated into design practice in the late twentieth century. Properly shaped, technologically advanced solutions of water spaces become an important element in the formation of architecture and landscape.

*Keywords: architecture, landscape architecture, architecture of water*

#### Streszczenie

Analizując europejskie realizacje architektoniczne, dostrzega się nowe podejście do zastosowania wody w architekturze współczesnej i kształtowaniu krajobrazu. Nowoczesne doświadczenie modelowania przestrzeni w trzech stanach skupienia wody (stały, ciekły i para wodna) poszerza koncepcję „architektury wodnej” włączanej do praktyki projektowej końca XX w. Odpowiednio kształtowane, zaawansowane technologicznie rozwiązania wodnych przestrzeni stają się ważnym elementem kształtowania architektury i krajobrazu.

*Słowa kluczowe: architektura, architektura krajobrazu, architektura wodna*

---

\* Ph.D. Arch. Liudmila Ruban, Kiev National University of Construction and Architecture (KNUCA), Kiev, Ukraine.

## 1. Introduction

Water is the key vital element to life in the Earth. It plays the great role in many aspects of human life, and in architecture and design as well. Architects, designers and, especially, landscape architects, always pay a special attention to water, as aesthetically all sufficient and decorative element of environment. At the end of 20<sup>th</sup> century we have noticed the surge of professional interest to the “architecture of water” and this interest still continues unabated. Moreover, recently emerged technologies give us an opportunity to reconsider our attitude to the “architecture of water” as not only a decorative environmental element [1]. Modern technologies show new possibilities of using water in construction – as a kind of constructive and creative material and as an informational carrier.

Water has a great number of unique properties. For instance, it is the only natural substance that appears in nature in all three common states of matter: solid, liquid, and gas. With each of these states we may encounter every day – snow, ice, water, clouds, fog and many other forms. And these three states of matter will be a departing point of our research.

### 2. The aims of research are:

- to explore the possibilities of new technologies of modelling the architectural space that appear on the market in the past decade, on the basis of the three states of water: gaseous, liquid and solid;
- to reveal the modern trends in architecture, landscape planning and building field on the basis of systematization of received data;
- to expand boundaries of a notion “architecture of water”.

### 3. Water as a primary construction material

The first part is dedicated to the review of water as a primary construction material. Architects, designers, artists often put themselves highly creative goals, and modern technologies help to reach them.

#### 3.1. *Vapour shell*

The Blur Building was a temporary media pavilion built for the Swiss Expo 2002. The authors of the idea – architects Elizabeth Diller and Ricardo Scofidio won the competition for the site in Yverdon with the idea of making an inhabitable cloud whirling above the water surface of the lake Neuchatel [2]. It is a great experience of design the construction, softly embraced by using vapourised water shell.

The idea is the following. The framework of a cloud is a system of rectilinear struts and diagonal rods cantilevered over the water. Rising out of Lake Neuchatel, a system of rectilinear struts and diagonal rods cantilevered over the water. The form is based on the work of Buckminster Fuller. The rods were fitted with over 30,000 fog nozzles shooting a fine mist pulled from the lake and controlled with a complex weather system. This fog

a)



b)



III. 1. The Blur Building – a media pavilion for Swiss EXPO, Lake Neuchatel, Yverdon-les-Bains, Switzerland, 2002 by Diller + Scofidio + Renfro: a) computer sketch of the ‘blur building’ b) aerial view of the ‘blur building’ on lake Neuchatel, 2002 (courtesy of Diller and Scofidio) [2]

a)

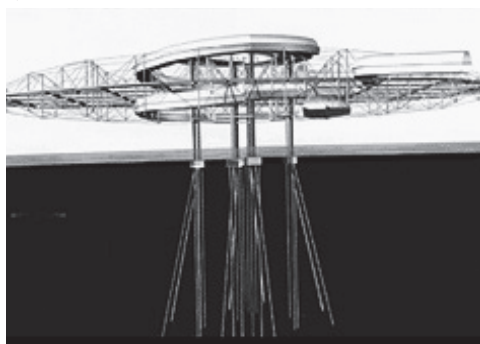

b)

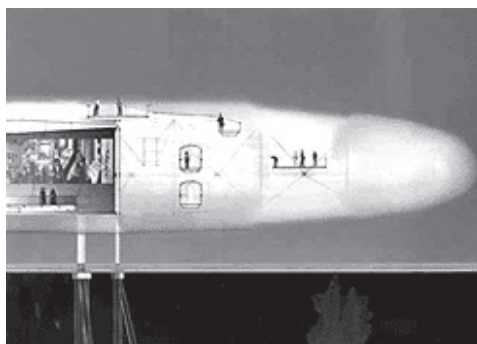

III. 2. The Blur Building – a media pavilion for Swiss EXPO, Lake Neuchatel, Yverdon-les-Bains, Switzerland, 2002 by Diller + Scofidio + Renfro: a) the construction of the artificial cloud; b) longitudinal section of the ‘blur building’ (courtesy of Diller and Scofidio) [2, 3]

created a man-made cloud that encompassed the metal framework to create the illusion of a vaporous building measuring 300 ft. wide and 65 ft. high [3]. A built-in weather station controls fog output in response to shifting climatic conditions such as temperature, humidity, wind direction, and wind speed.

Unfortunately, contrary to the Eiffel Tower, which was also initially build as an exhibition exponent and was lucky to left forever, this perception-altering exhibition was not built to be a permanent structure, and no longer exists.

### 3.2. *Liquid walls*

Sometimes designers are able to create things that other people would not even dream about. Engineers from MIT (Massachusetts Institute of Technology) wanted to create a kind

of building which could be flexibly adopted and may easily transform its shape in accordance to frequently changeable needs of people. Why not to use water as a main construction material for this purpose? Indeed, water is flexible enough and usually a liquid. So, a team of architects, engineers and inventors from the MIT in cooperation with their partners have constructed such liquid building for Zaragoza World Expo 2008. The Expo's theme was "Water and Sustainable Development", focusing in part on water as a unique resource, water for life, waterscapes and shared water. To achieve such previously unbelievable level of flexibility they combined 2 extremely different themes: good old water and modern digital technologies. The construction is called Digital Water Pavilion (DWP). It was an interactive structure made of digitally-controlled water curtains with exhibition area, tourist information centre and café inside [4].

The water walls that make up the structure consist of a row of closely spaced solenoid valves along a pipe suspended in the air. The valves can be opened and closed at high frequency, via computer control. The result is a space that is interactive and reconfigurable. So, each wall can potentially become an entrance or exit, while the internal partitions can shift depending on the number of people present. The walls are composed of digitally controlled water droplets, which can generate writing, patterns or access spaces. Designers of the digital water pavilion (DWP) describe it as a "building made of water" that "features liquid curtains for walls". The water "curtains" can be programmed to display images or messages and also can sense an approaching person and open a doorway to let that person enter without getting drenched.

"All the walls of the pavilion were made of digital water, as vertical partitions on the edge of the roof and inside it. The pavilion roof, covered by a thin layer of water, was supported by large pistons and can move up and down. When the pavilion is closed, the roof just collapses to the ground" [5]. DWC is designed to be placed outdoors and endure all types of hard weather conditions: rain, wind, heat, even mildly cold weather around freezing temperatures. Wind does not affect the DWC performance.

a)



b)



III. 3. The new digital technologies of "water walls": a) Digital Water Curtain® was created by Lumiartecnia Internacional, 2008 [4–6]; b) the AquaScript technology was created by German artist Julius Popp, 2007 [7]

“The DWP is the first attempt to use water walls on the architectural scale. Moreover, in the DWP water walls are not used merely as a decoration. In fact, they are a key element in the creation of changeable spaces and they act as a medium of communication”, said Matteo Lai, a member of the design team from architectural firm Carlo Ratti Associati of Turin, Italy [4]. The Digital Water Pavilion was selected as Time magazine’s “Best invention of the Year” in the field of architecture when its plans were unveiled in 2007. It was a pioneering construction of its kind and illustrated the potential of digital architecture in creating dynamically transformable spaces.

The fantastic creature of MTI wizards cognates with another interesting technology called AquaScript. Well-known English metaphor “writing on water” always used to refer to something transient quickly passed away and untrustworthy. AquaScript has proven this old stereotype is no longer valid. It was presented to public in 2007 at Tokyo Bay Monster-fashion show by German engineer Julius Popp [7].

The AquaScript information waterfall uses bitmap-rendered water streams to show both text and images in an engaging display. The basic AquaScript module is 2 meters long with a number of magnet-valves that can expel single water-drops on demand. A proprietary computer system and software synchronizes the valves so that the falling water-drops result in a freely definable bitmap-muster. Installation of AquaScript is very flexible. The array can be mounted on a rigging truss for temporary installation using half-couplers or also be fitted with bolts for fixed installation. An 8 meter AquaDisplay will use ~60 litres (~16 gallons) of water per minute. This depends on local water pressure and the density of the bitmaps used.

The Digital Water Curtain works as a ‘water plotter’, computer controlled that displays graphics, patterns and texts by switching fast acting valves on and off. This produces falling segments of water that serve as pixels, creating a surprising display that constantly scrolls downward. Digital Water Curtain® is a brand name created by Lumiartecnia Internacional [6].

### 3.3. *Ice constructions*

Basically, to be more precise, the usage of the water as a construction material is not purely recent invention. Water in its solid state as an ice or snow was traditionally used by people since prehistoric times. Many northern people, such as Eskimos preserved their tradition of building igloos and units often use ice caves for establishing their settlements. European people, both children and adult, always enjoyed winter season for having a chance to create ice or snow castles and other fun stuff. In fact, inside such cold chateaus it’s not so cold as it may be expected.

Until recent times for most of us, the extent of life under ice has been pretty limited or extremely exotic; however, since 1980, the first four ice hotels have set out to change that. Now almost everyone has a chance to feel how to be a true Eskimos. Usually, ice hotels are temporary buildings made up of snow, sculpted blocks of ice and in some cases, some steel framing. Most of the ice hotels are reconstructed every winter, and are dependent upon constant sub-freezing temperatures during construction and operation. “The hotel is usually made (the architecture and size may vary from season to season) in arches of 16 feet (5 m) over rooms. The walls are over 4 feet (1.2 m) thick on average. All furniture is usually also made of ice: the beds, the chairs, the counters, the glasses and more” [8].



a)



b)



III. 4. The Iglu Hotel and Bar at ski resort Grandvalira, Andorra, 2012: a) the entrance to the Ice bar; b) the interior design of main hall in Ice bar (photos by L. Ruban)

During last decade the Ice Hotels were opened in Sweden, Canada, Alaska (USA), Norway, Japan, Germany, Romania etc. Very often they provide additional après-ski facilities at some ski resorts, for example, in Andorra, Sweden, Norway, Canada etc.

Another popular type of ice-made attraction is ice bar. Today you can warm-up in a cold atmosphere of ice bars in almost all major cities, such as London, New York and others. And you can visit them any season. In Las Vegas, for example, sophisticated technology of maintaining the cold and new generation of insulating materials permitted to locate an ice bar in a middle of a desert – area with 40 C plus degree heat.

Beginning of the 21st century shows a steady development of the Ice Architecture Sector, the appearance of new buildings and facilities, a steady increase in demand for this type of vacation. Strong competition in tourism lead to emerging of new exotic ice objects such as elements of spa centres, churches, chapels, museums, sculptures etc. [8, 9]. The range of ice architecture is constantly expanding and does not seem to stop.

#### **4. Water as the habitat (environment of habitation)**

For the complete disclosure of a subject it's necessary to discuss three water states as habitat and design for mankind needs.

##### *4.1. Ice landscapes*

In 21 century the permafrost territories and glaciers became an attractive location for setting constructions which require natural subzero temperature conditions. Some companies establish their remote computer data centres where computers are cooled naturally without high power consuming cooling systems.

One of considerable events in the development of glaciers became a construction of a Global Seed Vault in Norway, 2008. It became a really distinguished construction not only from an architectural point of view but also for its purpose. The Svalbard Global Seed Vault (Norwegian: *Svalbard globale frohvelv*) is a secure seedbank located on the Norwegian island of Spitsbergen in the remote Arctic Svalbard archipelago, about 1,300 kilometres (810 mi) from the North Pole.

Spitsbergen was considered ideal due to its lack of tectonic activity and its permafrost, which will aid preservation. The storage is located in rocky subsoil at a depth of 120-meter and an altitude of 130 m above sea level, where temperature of  $-18^{\circ}\text{C}$  is constantly maintained. Such location ensures that the site remains dry even if the icecaps melt. According to developers of the project, even in case of a flood, falling of a meteorite or nuclear winter, the bank will be able to keep viability of all samples of a collection. Locally mined coal provides power for refrigeration units that further cool the seeds to the internationally recommended standard  $-18^{\circ}\text{C}$  ( $0^{\circ}\text{F}$ ). Even if the equipment fails, at least several weeks will elapse before the temperature rises to the  $-3^{\circ}\text{C}$  ( $27^{\circ}\text{F}$ ) of the surrounding sandstone bedrock [10].

Each country has own part in the storage. The variety and volume of seeds stored will depend on the number of countries participating – the facility has a capacity to conserve 4.5 million sorts of plants. Svalbard Global Seed Vault ranked at No. 6 on *Time's* Best Inventions of 2008.

#### 4.2. Underwater spaces

Life under water always excited admirers of creativity Jules Verne. At the beginning of 21 centuries it became possible thanks to the developed complicated technical solutions and emergence of new composite materials. Many of them were applied at construction of the underwater hotel of a Poseidon Undersea Resorts chain at Fiji (2008). The project was to be the world's first permanent one-atmosphere seafloor structure. 24 undersea suites are accessible by an elevator that takes guests 40 ft. below the surface. Nearly 70 percent of these rooms will be wrapped in 4-inch-thick clear acrylic, providing guests with a more-than-panoramic view of the ocean around them, and guests can use an in-room control console to encourage marine life to their windows with external feeding and lighting options [11]. All guests can use a submarine or a special tunnel from the beach to get into the underwater restaurant, bar, a library, conference room, wedding chapel or spa. Poseidon was conceived and developed by L. Bruce Jones, president of U.S. Submarines, Inc.

The first underwater hotel, which was built in 1986, was Jules' Undersea Lodge located in Key Largo, Florida. However its guests had to scuba dive to get to their room at a depth of 21 feet (6.4 m) under water [12].

#### 4.3. Indoor vapour

The fact of sustained usage of vapour in architecture relates to the far future. For the present it is not so easy to make a long forecast. Today, painters and sculptors widely use vapour like a creative element for art-installation. That is why the new technology of man-made vapour appeared. Creating clouds indoors is only possible through climate engineering, by applying physical principles at the building scale.

The technology of skilfully created clouds (Nimbus) inside indoor spaces was based on controlling the weather conditions of a room. It is an act that requires meticulous planning entailing carefully controlling the temperature and humidity levels of the room, constantly moistening the air inside it and adjusting the lighting to create a dramatic and realistic effect. The Nimbus was created by Berndnaut Smilde – the artist from Holland in 2010–2012 [13].

Another example of similar technology is represented by so called Cloudscapes by Tetsuo Kondo Architects and environmental engineering firm Transsolar. They have suspended a cloud inside the Arsenale exhibition space at the Venice Architecture Biennale 2010. The installation Cloudscapes was created by pumping three layers of air into the space: cold dry air at the bottom, hot humid air in the middle and hot dry air at the top. The installation formed part of the exhibition People Meet in Architecture, directed by Kazuyo Sejima of SANAA [14].

## 5. The results of research

We have considered the advanced experience of modelling of the architectural space by usage of water. Main highlights are summarized in the flowchart “Recent trends in the usage of ‘water’ in modern architecture” (Ill. 5).

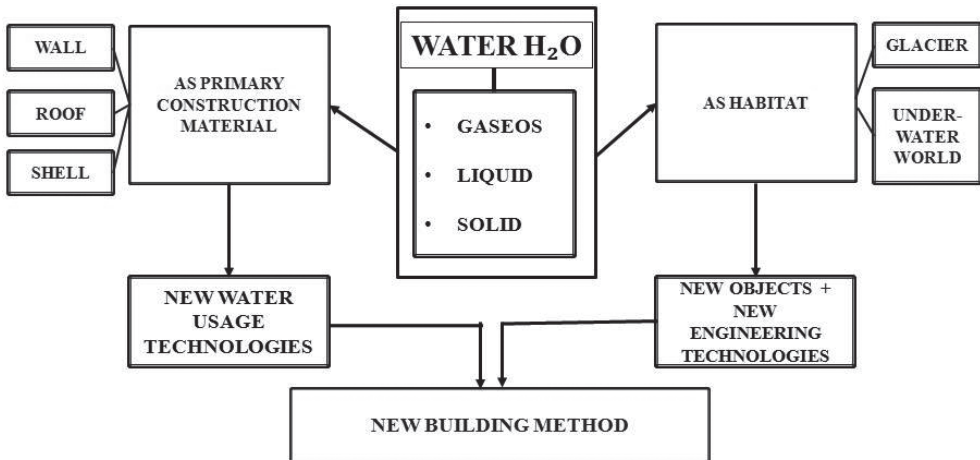

Ill. 5. The flowchart “Recent trends in the usage of ‘water’ in modern architecture” (by author)

It became possible by using of new technologies. The modern technologies connected with the usage of water and the development of unusual environment of habitation such as Arctic permafrost or underwater space represented in the Table 1.

**Main technologies used in the modelling of architectural space (by author)**

Date of appearance	Main technology	Country of realization
2002	DIMENSIONAL METAL FRAMEWORK by BUCKMINSTER FULLER	Switzerland
2002	TECHNOLOGY of ARTIFICIAL CLOUD (THE FOG HIGH PRESSURE NOZZLES)	Switzerland
2007	AQUASCRIPTE TECHNOLOGY by JULIUS POPP(Germany)	Japan
2008	DIGITAL WATER CURTAIN® by LUMIARTECNIA INTERNACIONAL	Spain
Since 1980	TECHNOLOGY of BUILDING STRUCTURE MADE UP OF SNOW, SCULPTED BLOCKS OF ICE	all over the world
2008	BUILDING METHOD IN PERMAFROST	Norway, North Poll
2008	UNDERWATER BUILDING TECHNOLOGIES:	Fiji
2008	USAGE OF NEW ACRYLIC MATERIALS	Fiji
2008	TECHNOLOGY of INROOM CONTROL CONSOLE etc.	Fiji
2010	METHOD OF CREATION CLOUDSCAPES by TETSUO KONDO ARCHITECTS AND ENVIRONMENTAL ENGINEERING FIRM TRANSOLAR (JAPAN)	Italy
2010–2012	METHOD OF CREATION OF AN INDOOR CLOUD NIMBUS by BERNDNAUT SMILDE (HOLLAND)	UK

## 6. Conclusions

Today it's possible to state, that the first decade of the new century is characterized by a technological shift, when water turned from decorative element into construction material. Water can be used in all its three states of matter, as it was shown by some recent constructional projects.

If, concerning usage of water in gaseous or liquid states – they're newest technologies, such as Digital Water Curtains, Aquascript etc. Water was used for making walls, roofs, vapourised water shell. Today mostly digital technologies worked out to show its potential in creating of dynamically transformable spaces. There is a trend for uniting and combination of several technologies together at the same time. For instance, iron construction may be combined with vaporized system or water flow with climate control technology may coexist with informational carrier.

But regarding solid state – it is a phase of further technological improvement and aesthetic development. Freezing technology and maintaining low temperatures, as well as the emerging of new insulating materials contribute to further spread of ice constructions. The steady occupation of its segment in the construction market is indicated together with extending the construction nomenclature.

Another interesting perspective is the developing of new habitats, like adaptation of glaciers or underwater spaces for living. This becomes possible due to further development of modern engineering technologies, computer software and introduction of new composite materials. The progress in construction technology enables the emerging of functional objects, such as computer data centres or seed storages.

Widespread of water in gas state is possible, but it's quite a distant future. Today vapour mostly predominates in some art installations, and, traditionally, at SPAs – e.g. in hamams.

In fact, worlds Expos have always been venues to preview new and innovative architecture. Recently emerged technologies give us an opportunity to reconsider our attitude to the “architecture of water”. Today the specific water technologies are used to create XXI century's architecture.

## References

- [1] Ruban L., *Modern Trends in the Usage of Water in Contemporary Architectural-Landscape Practice*, The new Ideas of New Century – 2014: The Fourteenth International Scientific Conference Proceedings: in 3 vol., Pacific Ocean state university, Ed. Pacific Ocean state university, Habarovsk 2014, V. 3, 160-166.
- [2] Architecture now!, editor P. Jodidio, Hong Kong, Koln, London, Los Angeles, Madrid, Paris, Tokyo, Taschen, 2002, 192.
- [3] Klimek D., Blur Building (Yverdon-les-Bainz, Switzerland), 2012, October, 17 (<http://prezi.com/fmqegooyknqt/blur-building-yverdon-les-bainz-switzerland>, access: 18.08.2014).
- [4] <http://www.carloratti.com/project/digital-water-pavillion>, access: 19.08.2014.
- [5] Bolles D., Pavilion Made of ‘Digital Water’ Merges Science and Technology 2007, Sep.11 (<http://eonline.com/articles/2007/09/11/pavilion-made-of-digital-water-merges-science-and-technology.aspx>, access: 19.08.2014).
- [6] <http://www.digitalwatercurtain.com>, access: 20.08.2014.
- [7] <http://www.technovelgy.com/ct/Science-Fiction-News.asp?NewsNum=1435>, access: 18.08.2014.
- [8] [http://en.wikipedia.org/wiki/Ice\\_Hotel\\_\(Quebec\)](http://en.wikipedia.org/wiki/Ice_Hotel_(Quebec)), access: 20.08.2014.
- [9] Gardner F., A cool place to hang out: Snow sculptures and an open-air Jacuzzi at the igloo hotel, published 2012, October, 28 (<http://www.dailymail.co.uk/travel/article-2224340/The-Iglu-Dorf-hotel-Germany-boasts-snow-sculptures-ice-bar-open-air-Jacuzzi-brave-night-ice.html>, access: 20.08.2014).
- [10] [http://en.wikipedia.org/wiki/Svalbard\\_Global\\_Seed\\_Vault](http://en.wikipedia.org/wiki/Svalbard_Global_Seed_Vault), access: 20.08.2014.
- [11] <http://www.recommend.com/themes/active/sleep-fishes-poseidon-resorts/>, access: 20.08.2014.



- [12] [http://en.wikipedia.org/wiki/Jules\\_Undersea\\_Lodge](http://en.wikipedia.org/wiki/Jules_Undersea_Lodge), access: 20.08.2014.
- [13] <http://www.yatzer.com/nimbus-berdnaut-smilde>, access: 20.08.2014.
- [14] Cloudscapes by Tetsuo Kondo Architects and Transsolar, 2010, September, 6 (<http://www.dezeen.com/2010/09/06/cloudscapes-by-tetsuo-kondo-architects-and-transsolar>, access: 20.08.2014).



STRUCTURES

---

KONSTRUKCJE



TOMASZ DOMAŃSKI\*

## RELIABILITY OF GLUED TIMBER ROOFS BELONGING TO CC3 CLASS CONSEQUENCES OF FAILURE

### NIEZAWODNOŚĆ DACHÓW Z DREWNA KLEJONEGO O KLASIE KONSEKWENCJI ZNISZCZENIA CC3

#### Abstract

The arenas with great grandstands are the public places where the consequences of failure are very high. For this reason, according to EN 1990, they belong to CC3 class consequences of failure. The reliability class RC3 is associated with the consequences class CC3 and is defined by the reliability index  $\beta = 4.3$  with probability of failure  $p_f = 8,54 \cdot 10^{-6}$ . The distributions of horizontal and shear resistance within glued timber body – bolts will be described depending on material characteristics of glued timber body and bolts components. The paper will present methods of timber structural design belonging to CC3 consequences failure class.

*Keywords: structural reliability, timber structures, timber joints*

#### Streszczenie

Konstrukcje budowlane takie jak hale sportowe, widowiskowe, w których konsekwencje awarii są bardzo wysokie zaliczane są wg normy PN-EN 1990 „Podstawy projektowania konstrukcji” do klasy konsekwencji zniszczenia CC3. Klasie CC3 odpowiada klasa niezawodności RC3, która jest definiowana przez wskaźnik niezawodności  $\beta = 4,3$ . W klasie CC3 definiuje się dopuszczalne prawdopodobieństwo awarii na poziomie  $p_f = 8,54 \cdot 10^{-6}$ . W pracy przedstawione zostaną metody projektowania elementów konstrukcji przykryć oraz ich połączeń tak aby obiekty te mogły być zakwalifikowane do klasy konsekwencji zniszczenia CC3.

*Słowa kluczowe: bezpieczeństwo konstrukcji, drewno klejone, połączenia drewniane*

\* Ph.D. Tomasz Domański, Institute of Building Materials and Structures, Cracow University of Technology.



## 1. Introduction

Safety assessments of timber members require taking into consideration many different reasons. The main reason of glued timber structure failure is connection damage. The shear connection will be discussed in this paper. Shear connections have to transfer forces between structural members – glued timber body and bolts with adequate degree of safety. The load-carrying mechanism of bolted shear connections is complex and analytical methods for predicting the shear resistance are not applicable. Instead, the resistance of the connections may be determined using empirical formulas. The distributions of horizontal and shear resistance within glued timber body – bolts will be described depending on material characteristics of glued timber body and bolt components. The characteristic resistance of timber shear connection is obtained as a minimum of two variables: bolts resistance and steel body resistance. Probability function of these minima will be defined and described in this paper. Laboratory tests provide the only practicable basis for specifying safety margins for ultimate strength connections.

## 2. Probabilistic distributions of basic strength properties

According to EN-1995-1-1, the design value  $X_d$  of a glued timber basic strength property shall be calculated as:

$$X_d = k_{\text{mod}} \frac{X_k}{\gamma_M} \quad (1)$$

where:

- $X_k$  – characteristic value of basic property,
- $k_{\text{mod}}$  – modification factor, defined in EN 1995,
- $\gamma_M$  – partial safety factor for connections defined in EN 1990.

The distribution parameters can be determined up on the information given in Table 1.

Table 1

**Distributions of basic properties**

Property	Distribution	COV
Bending strength $f_{m,k}$	lognormal	0.19
Bending modulus of elasticity $E_{0,\text{mean}}$	lognormal	0.08
Glued timber density $\gamma_k$	normal	0.07

### 3. Damage model assumptions

The Eurocode for glued timber structures EC5, EC0 [1, 2], refers to this strength modification with a load duration factor  $k_{\text{mod}}$ . Traditionally, the load duration factor is determined empirically by experience on glued timber structures, but there are probabilistic methods connected with damage accumulation models to estimate factor  $k_{\text{mod}}$  as well [3]. The load duration factor  $k_{\text{mod}}$  is defined in EC5 as a factor which takes into account the effects of load duration and ambient climate on the strength parameters of structural glued timber members. The mechanism, leading to the reduction in strength of a glued timber member under sustained load, is a creep rupture. This could arise from propagation of voids in the microstructure of the timber at a stress level lower than the short-term strength. A number of models of creep rupture, involving a damage state variable (similar to that used in the analysis of metal fatigue), have been proposed to assess damage accumulation in wood structural members subject to loading histories, typically modeled as a renewal pulse process. The basic model has the following form [4]:

$$d\alpha/dt = F[\sigma(t)] \quad (2)$$

where:

- $t$  – time,
- $\alpha$  – the damage state variable which ranges from 0 (no damage) to 1 (failure), the function  $F(\cdot)$  has two constants that must be determined from test data,
- $\sigma(t)$  – the ratio of the applied stress to the failure stress under short-term loading.

### 4. Calibration of modification factor $k_{\text{mod}}$ for Tatra mountain zone

The occurrence of snow packages at times  $X1, X2$  is modelled by the Poisson process. The duration between snow packages is exponentially distributed with expected value  $1/\lambda$ , where:  $\lambda$  – expected number of snow packages per year,  $\lambda = 1.95$  snow packages per year.

- The magnitude of the maximum snow load  $P_m$  in one snow package (snow pulse) is assumed to be Gumbel distributed (expected value  $\mu_p = 0.78$  kN/m<sup>2</sup>, standard deviation  $\sigma_p = 0.39$  kN/m<sup>2</sup>).
- The duration of a snow package  $T$  is modelled by  $X_T P_m$ , proportional to the maximum snow load of snow package  $X_T$  – exponentially distributed with expected value  $\mu_{X_T} = 145$  days/(kN/m<sup>2</sup>).
- The time variation of snow packages is assumed to be rectangular.
- The annual maximum snow load on timber roof is determined by:

$$Q_{S,\text{max}} = C P_{SG,\text{max}} \quad (3)$$

$P_{SG,\text{max}}$  is annual maximum snow load on the ground and is Gumbel distributed (expected value  $\mu_s = 1.86$  kN/m<sup>2</sup> and standard deviation  $\sigma_s = 0.43$  kN/m<sup>2</sup>).  $C$  is shape factor and is

assumed Gumbel distributed. Characteristic value of maximum snow load  $P_{SG, \text{char}}$  on the ground, was obtained for a  $T = 50$  year reference period [6].

In the code format EC5, load duration effect is represented by a modification factor  $k_{\text{mod}}$ . The following design equation can be found in the codes [7].

$$\frac{zf_k k_{\text{mod}}}{\gamma_m} - \left( (1 - \kappa) \gamma_G G_k + \kappa \gamma_Q Q_k \right) = 0 \quad (4)$$

Where  $z$  is the design variable,  $f_k$  and  $Q_k$  are the characteristic values of short-term strength and variable load,  $\gamma_m, \gamma_Q$  are the partial safety factors and  $\kappa$ , the coefficient,  $0 \leq \kappa \leq 1$ .  $G_k, \gamma_G$  are characteristic value and partial safety factors of permanent loads.

In the following probabilistic approach [4, 5] all uncertainties related to strength, model and loads are included in a way consistent with the background for the partial safety factors in Polish structural codes. The limit state function for the long-term load carrying capacity can be formulated as:

$$g = 1 - \alpha(f_o, G, Q, A, B, T_L, \kappa) \quad (5)$$

where:

- $\alpha$  – is the damage function obtained from (1),
- $f_o$  – the short term strength,
- $A, B, C$  – the parameters in damage accumulation model,
- $G$  – the permanent load,
- $Q = Q(t)$  – the variable load as a function of time.

Taking into account the decrease with time of the strength, the following alternative limit state equation is used:

$$g = z(1 - \alpha)f_o - \left( (1 - \kappa)G + \kappa Q \right) \quad (6)$$

Then  $k_{\text{mod}}$  factor can be estimated as follows:

$$k_{\text{mod}} = \frac{\gamma_m^S(\beta)}{\gamma_m^L(\beta)} \quad (7)$$

Where  $\beta$  is the reliability index (EC 0)  $\beta = 4.8$  for Polish standards. The partial safety factor for the long-term strength  $\gamma_m^L(\beta)$  is calibrated to a target reliability index  $\beta$ . The partial safety factor for the short-term strength  $\gamma_m^S(\beta)$  was obtained using equation (6) with  $k_{\text{mod}} = 1$ . Table 2 presents  $k_{\text{mod}}$  factors for different expected duration of snow packages.

**$k_{\text{mod}}$  modification factors for Tatra zone**

$\mu_{Xt} = 145 \text{ days}/(\text{kN}/\text{m}^2)$	1	0,5	0,25	0,15	0,10	0,05
$k_{\text{mod}}$	0.72	0,74	0,76	0,78	0,80	0,84

## 5. Modelling of double shear glued timber connections

### 5.1. Characteristic value of double glued timber connection

The load capacity of two shear glued timber members connections in EN-1995-1-1 models based on the so-called Johansen model. The rigid – plastic model for connecting glued timber elements is assumed. The elastic model of steel is applied for steel fasteners. A few possibilities of fastener damage are being considered. This should be connected with glued timber presser  $F_{JH,1}$ ,  $F_{JH,2}$  and with steel fastener bending capacity  $F_{JH,3}$  and  $F_{JH,4}$ . These capacities with line effect  $F_{ax,R}$  are described as follows:

$$F_{JH,1} = f_{h,1} t_1 d \quad (8)$$

$$F_{JH,2} = 0.5 f_{h,2} t_2 d \quad (9)$$

$$F_{JH,3} = 1.05 \frac{f_{h,1} t_1 d}{2 + \beta} \left[ -\beta + \sqrt{2\beta(1 + \beta) + \frac{4(\beta(2 + \beta)M_{y,R})}{f_{h,1} d t_1^2}} \right] + \frac{F_{ax,R}}{4} \quad (10)$$

$$F_{JH,4} = 1.15 \sqrt{\frac{2\beta}{1 + \beta}} \sqrt{2M_{y,R} f_{h,1} d} + \frac{F_{ax,R}}{4} \quad (11)$$

$$\beta = \frac{f_{h,2}}{f_{h,1}}, \quad M_{y,R} = 0.3 f_u d^{2.6}, \quad f_{h,i} = 0.082(1 - 0.01d) \rho_i, \quad i = 1, 2$$

The values  $F_{JH,1}$ ,  $F_{JH,2}$ ,  $F_{JH,3}$ ,  $F_{JH,4}$  are calculated upon 5% fractile basic variables as: glued timber strength  $f_{h,i}$ , density  $\rho_i$ , fastener steel strength  $f_u$ . The characteristic value of double glued timber member's connection  $F_{v,Rk}$  is obtained as minimum of partial capacities according to EN 1995-1-1:

$$F_{v,Rk} = \min(F_{JH,1,k}, F_{JH,2,k}, F_{JH,3,k}, F_{JH,4,k}) \quad (12)$$

## 5.2. Design value of double glued timber connection

Following EN 1995-1-1 design value of glued timber connection  $F_{v,Rd}$  was obtained as:

$$F_{v,Rd} = k_{mod} \frac{F_{v,Rk}}{\gamma_M} \quad (13)$$

Generally, using EN 1990 assumptions, design value of glued timber connection  $F_{v,Rd}$  can be described as:

$$F_{v,Rd} = F^{-1}(F_v; \Omega, f, f_{conn}, X, T, p_f) \quad (14)$$

where:

- $F^{-1}(\cdot)$  – probability distribution fractile on level  $p_f = \Phi^{-1}(\beta)$ ,  $\beta$  – reliability index for target reliability class according to EN 1990,
- $\Phi(\cdot)$  – Laplace function,
- $F_v$  – random glued timber capacity,
- $\Omega$  – kind connection,
- $f, f_{conn}$  – random parameters of strengths.

For CC3 class consequences of failure design value of shear resistance of connection  $F_{v,Rd}$  for  $T = 50$  year period is defined as follows:

$$F_{v,Rd} = k_{mod} F^{-1}[F_v; \Omega, f_0, f_{conn}, X, p_f = \Phi^{-1}(4.3)] \quad (15)$$

## 6. Probabilistic model

The variables of glued timber strength  $f_h$  and steel fastener strength  $f_u$  are random. These random variables are characterized by adequate probability distribution functions  $P(\cdot)$  and the first two probabilistic moments  $Ex(\cdot)$ ,  $Ex^2(\cdot)$ . It is assumed that probability density functions of glued strength and steel fastener strength are log-normal with coefficients of variation  $v_{f_h} = 0.25$  and  $v_{f_u} = 0.07$ . The expected values depend on glued timber classes and fastener steel grades. There is a new random variable  $F_{JH}$

- joint capacity defined as a minimum of the partial joint strengths  $F_{JH,i}$ :

$$F_{JH} = \min_{i=1..4} (F_{JH,i}) \quad (16)$$

The form and parameters of probability functions of glued timber joint capacity  $F_{JH}$  are unknown. The statistical moments  $E(\cdot)$ ,  $Var(\cdot)$  of random variable  $F_{JH}$  were established upon Monte Carlo methods specifying histogram  $P^{MC}(F_{JH})$ . The form of probability function of  $F_{JH}$  is conveniently defined by minimum cross-entropy  $H$  condition [8].

$$H(P^{MC}, P^*; f_i) = \sum_i P^*(f_i) \ln \frac{P^*(f_i)}{P^{MC}(f_i)} \quad (17)$$

The characteristic values  $F_{JH,k}$ , design value for CC3 classes of consequence of failure  $F_{JH,d}$  partial safety factor are obtained by using the following formulas:

$$F_{JH,k} = P^{*-1}[\Theta(-1.64)], \quad F_{JH,d} = P^{*-1}[\Theta(-4.3)], \quad \gamma_M = F_{JH,k} / F_{JH,d} \quad (18)$$

### Example

Three examples of glued timber GL 24 h member double shear connections are considered. The steel fastener thicknesses are T1, 2T1, T1 with class 4.8 and diameter  $D$ . Three cases of thicknesses T1 = 50 mm, 100 mm, 150 mm and two cases of diameters  $D = 10$  mm, 16 mm are taken into account. The subscript “1” is connected with joint capacity described by using formula (8), subscript “2” – formula (10) and subscript “3” (11). Total capacity of glued joint is without subscript. The example presents the cases with: positive skewness –  $G$  – Gumbell (Frechet) probability distributed, neutral skewness –  $N$  – (Normal) distributed and negative skewness (Weibull)  $W$ . The Table 3 shows characteristics of random vectors generated using the Monte Carlo method –  $E(\cdot)$  – expected value,  $COV(\cdot)$  – Coefficient of Variation for tree options (A), (B), (C). Table 4 shows final results of joint capacity estimation, columns 6, 7 represent the characteristic and design values calculated using probabilistic methods and columns 8, 9 – using Eurocode procedures.

Table 3

### Probabilistic partial joint capacity parameters

	D1 [mm]	T1 [mm]	$E(1)$ [kN]	$COV(1)$	$E(2)$ [kN]	$COV(2)$	$E(3)$ [kN]	$COV(3)$
(A)	16	100	52.11	0.19	40.93	0.13	72.62	0.12
(B)	16	150	89.2	0.18	46.43	0.15	72.12	0.13
(C)	10	50	16.61	0.20	19.68	0.11	33.43	0.11

Table 4

### The glued timber joint capacity parameters

1	2	3	4	5	6	7	8	9
Option	Expected value [kN]	Coefficient of variation	Skewness	Prob. distr.	$F_{JH,k}$ [kN] Prob.	$F_{JH,d}$ [kN] Prob.	$F_{v,Rk}$ [kN] EN	$F_{v,Rd}$ [kN] EN
(A)	35.91	0.14	0.07	$N$	41.63	34.27	44.48	37.37
(B)	39.65	0.16	0.68	$G$	42.23	40.29	45.89	44.57
(C)	13.97	0.18	-0.19	$W$	14.36	11.47	12.34	15.89



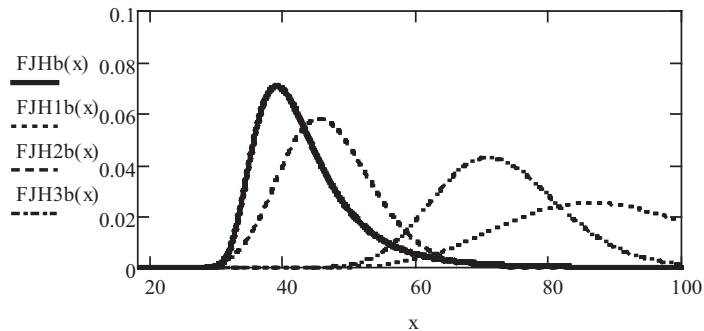

III. 1. Minimization of random variables of timber glued joint capacity

## 7. Conclusions

The probabilistic models for the glued timber joints with dowels in double shear have been formulated in such a way that they can be easily applied in structural reliability analysis. It has been noticed that a significant effect was found in the time variation of snow impulses-packages on the accumulated damage. Therefore the observed snow packages are quite different and the triangular and rectangular time variations are included in the present probabilistic calibration of load duration factors. The probability functions of capacity of timber joints in double shear connections were estimated with the entropy criterion. The target reliability index equal 1.64 and 3.4 was used to obtain characteristic and design capacity of double shear joints. More research is needed on the variance parameters, as found in practice, of the glued timber characteristic joints and on the assumptions of the shape of capacity probability distribution of glued timber joints.

## References

- [1] EN 1990 – Basis of Structural Design.
- [2] EN 1995-1-1 – Design of Timber Structures.
- [3] Gerhard C., *Time related effects on wood strength, a linear cumulative damage theory*, Wood Sci, 11(3), 1979, 139-44.
- [4] Kohler J., Sorensen J., Faber M., *Probabilistic Modeling of Timber*, Structural Safety 29, 2007, 255-267.
- [5] Domanski T., *Snow Load Duration Effects on Timber Roofs*, Proc. of the 10<sup>th</sup> International Conference. Modern Building Materials, Structures and Techniques Vilnius, Lithuania, 2010, 856-863.
- [6] Institute of Meteorology and Water Management, Krakow, Poland.
- [7] Smith I., Follente G., *Joints Design of Timber Load and Resistance Factor*, International Practice and Future Direction, Journal of Structural Engineering, Vol. 128, No. 1, January 1, 2002, 48-59.
- [8] Soofi E.S., Ebrahimi N., Haibullah M., *Information Distinguishability with Application to Analysis of Failure Data*, Journal of the American Statistical, Association, Vol. 90.

ROMAN KINASH\*, VITALIJ BILOZIR\*\*

## DEFORMATIONAL CALCULATION METHOD OF BEARING CAPABILITY OF FIBER-CONCRETE STEEL BENDING ELEMENTS

### ODKSZTAŁCENIOWA METODA OBLICZANIA NOŚNOŚCI ZGINANYCH ELEMENTÓW FIBROBETONOWYCH Z WŁÓKNAMI STALOWYMI

#### Abstract

This article proposes to use parabolic-linear diagram of deformation of steel fiber concrete under the conditions of compression. General principles of calculation method of steel fiber concrete elements, with the use of deformation diagrams of steel fiber concrete, have been submitted. The aim of this study was to present a method for calculating the deformation and deformation capacity steel fiber concrete bending elements based on the results of experimental studies. Results of tensile testing of samples allowed to put forward an analytical description of the time dependence of the stress-strain of steel fiber concrete in tension and compression, and accurately calculate the load and deflection bending elements. The experimental significance of the bearing capacity of steel fiber concrete bending elements on the fiber from the sheet and theoretical implications calculated by the proposed method have shown quite a good convergence.

*Keywords: steel fiber concrete, diagram, design, deformations*

#### Streszczenie

W artykule przedstawiono podstawowe zasady i metody obliczania zginanych elementów stalefibrobetonowych za pomocą paraboliczno-prostokątnych wykresów odkształceń stalefibrobetonu. Celem niniejszej pracy było zaproponowanie odkształceniowej metody obliczania nośności i odkształcenia stalefibrobetonowych elementów zginanych opartej na wynikach badań doświadczalnych. Wyniki badania próbek na rozciąganie pozwoliły na zasugerowanie analitycznego opisu wykresów zależności „naprężenie–odkształcenie” stalefibrobetonu przy rozciąganiu i ściskaniu oraz dokładniejsze obliczenie nośności i ugięcia elementów zginanych. Doświadczalne wartości nośności stalefibrobetonowych elementów zginanych z włóknami stalowymi i wartościami teoretycznymi obliczonymi według proponowanej metody wykazały dobrą zbieżność.

*Słowa kluczowe: stalefibrobeton, wykres, obliczenie, odkształcenie*

\* Prof. Ph.D. Eng. Roman Kinash, AGH University of Science and Technology, Department of Geomechanics, Civil Engineering and Geotechnics; Lviv Polytechnic, Department of Architectural Constructions.

\*\* Ph.D. Eng. Vitalij Bilozir, Department of Civil Engineering and Architecture, Lviv National Agrarian University.

## 1. Introduction

Exertion of fiber reinforcement to reinforce concrete allows us to enhance its exploitation qualities. These can include: lifted comparing to regular concrete resistance to cracking, firmness to stretching and pressure, frost resistance, shockproof, toughness to destruction etc. However, in case of changing diametrical reinforcement of beams and nets, which are used to reinforce the slabs, it is possible to reduce the labor intensity of the production of constructions.

So the calculation method of the bearing capacity of steel fiber elements is crucial [1, 2] and has been elaborated by the analogy of reinforcement cement constructions. Thus at the stage of utmost balance, rectangular distribution diagrams of the strain of steel fiber concrete have been accepted in compact and stretch zones. The research, which has been conducted recently, has shown that such an approach is not fully reasoned and can lead to the situation when the constructions which were calculated according to the norms [1, 2], won't meet the reliability requirements. Therefore, the improvement of the calculation method for steel fiber concrete bending elements on the basis of using whole diagrams of deformation of steel fiber concrete and reinforcement is a problem, the solving of which is explained below.

## 2. Analysis of latest research and publications

In this work [3] it is proposed to use parabolic-linear diagram of deformation of steel fiber concrete under the conditions of compression. By the equation of a parabola, the ascending branch is described up to the level of strains, which are equal to temporary resistance  $f_{fc}$ , and to linear equations  $\sigma_{fc} = f_{fc}$ , in the rest of the diagram. The diagram, under the conditions of distension in the form of a parabola, the ascending branch and hyperbola or bilinear function, is at the descending. Experimentally received results concerning the diagram in assignment [3] haven't been provided.

The specialists of the German committee on concrete, offer an idealized diagram under the extension of steel fiber concrete which is accepted as three-cornered [4]. The ascending branch of this diagram is continuing as a horizontal line to deformations which equal  $\varepsilon_{fct} = 3.5 \cdot 10^{-3}$ , descending branch is finishing under the deformations  $\varepsilon_{fct} = 25 \cdot 10^{-3}$ .

The work [5] has used the diagrams under extension and pressing, in a way of non-linear functions without descending branches.

Therefore, there is a list of propositions regarding the description of idealized diagrams, the parameters of which have not yet enough experimental explanation. Deformation diagrams are recommended to be used only at the stage of destruction, thus its criteria is to reach utmost deformation in concrete or reinforcement [3–5]. The aforementioned works didn't consider such criteria as being upper bound of bearing capacity at the diagram “bending moment – flexion”, which means the loss of balance abilities at the stretched and compressed zones of a bending element.

The aim of this work is to elaborate the deformation method of calculation of steel fiber concrete bending elements on the fiber of the sheet. The objectives of the research are the following: analytically describe whole diagrams of deformation of steel fiber concrete which were received in the assignment [6], elaborate mathematical apparatus to

calculate bearing capacity of steel fiber concrete bending elements, compare the results of the calculations and experimentally received data trying out steel fiber concrete bending samples of beam slabs.

### 3. The method of calculating the deformation capacity of bending elements

The proposed parameters of idealized diagrams when they are stretched or compressed (Ill. 1) are well matched with the results of experimental research received in work [6] and they have a lot in common with the appropriate parameters of hard constructional concrete [7].

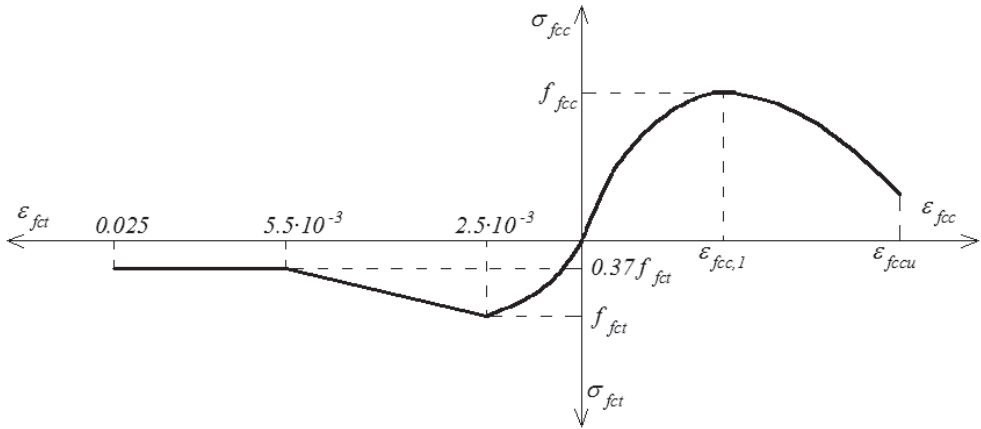

Ill. 1. Idealized diagrams of deformation of steel fiber concrete on the fiber of the sheet under stress and stretching

Here is compression stress:

$$\sigma_{fcc} = f_{fcc} \sum_{k=1}^5 a_k \eta_c^k \quad (1)$$

where:

$$\eta_c = \frac{\varepsilon_{fcc}}{\varepsilon_{fccu,1}},$$

$a_k$  – polynomial coefficients;

– under the extension of ascending branch:

$$\sigma_{fct} = f_{fct} \sum_{k=1}^5 a_k \eta_t^k \quad (2)$$

where:

$$\eta_t = \frac{\varepsilon_{fct}}{2.5 \cdot 10^{-3}};$$

– at the descending branch:

$$\sigma_{fcc} = f_{fct}(1.525 - 210\varepsilon_{fct}) \quad (3)$$

In the formulas (1), (2) the coefficients  $a_k$  are the polynomial coefficients which were calculated by the method accepted at work [7] and takes into consideration the experimental data [6]:

– at pressing:

$$a_1 = \frac{1.1E_{fc}\varepsilon_{fcc,1}}{f_{fcc}}$$

– at stretching for ascending branch:

$$a_2 = 1 - a_1 - a_3 - a_4 - a_5, \quad a_3 = a_1 - 2a_4 - 3a_5 - 2$$

$$a_4 = \left\{ \left[ k - 2a_1(3\gamma - 2) + 12\gamma - 6 \right] - 2a_5(10\gamma^3 - 9\gamma + 2) \right\} / \left[ 2(6\gamma^2 - 6\gamma + 1) \right]$$

$$a_5 = \left\{ \left[ k - 2a_1(2\gamma - 3\gamma) + 12\gamma - 6 \right] (\gamma - 1)^2 \gamma^2 - \left[ \beta + a_1\gamma(2\gamma - \gamma^2 - 1) + \gamma^2(2\gamma - 3) \right] (6\gamma^2 - 6\gamma + 1) 2 \right\} / \left\{ 2\gamma^2 \left[ (10\gamma^3 - 9\gamma + 2)(\gamma - 1)^2 - (\gamma^3 - 3\gamma + 2)(6\gamma^2 - 6\gamma + 1) \right] \right\}$$

where:

– at pressing:

$$\gamma = \frac{\varepsilon_{fccu,1}}{\varepsilon_{fcc,1}}$$

– average value at the stretching for ascending branch:

$$\gamma = \frac{\varepsilon_{fctu,1}}{\varepsilon_{fct,1}} = \frac{2.5 \cdot 10^{-3}}{5.5 \cdot 10^{-3}} = 0.455$$

– at pressing:

$$\beta = \frac{1.1\varepsilon_{fccu,1}}{\varepsilon_{fcc,1}}$$

- at stretching for ascending branch:

$$\beta = \frac{5.5 \cdot 10^{-3}}{2.5 \cdot 10^{-3}} = 2.2$$

- at pressing:

$$k = 2.7 \cdot \left( \frac{\varepsilon_{fccu,1}}{\varepsilon_{fcc,1}} \right) - 6.1 - \frac{0.05}{\left( \frac{\varepsilon_{fccu,1}}{\varepsilon_{fcc,1}} - 1 \right)^2}$$

- at stretching:

$$k = 2.7 \cdot \left( \frac{5.5 \cdot 10^{-3}}{2.5 \cdot 10^{-3}} \right) - 6.1 - \frac{0.05}{\left( \frac{5.5 \cdot 10^{-3}}{2.5 \cdot 10^{-3}} - 1 \right)^2} = -0.195$$

The formulas (1)–(3) describe quite precisely the diagrams of pressing and stretching of steel fiber concrete up to the level of relative deformations which are  $3 \cdot 10^{-3} \dots 4 \cdot 10^{-3}$  at the stretching and pressing. Theoretically received meaning of appropriate tensions, only at certain dots, exceed the experimental ones at 0,3...3,5%, but in most cases they are less, thus the equation (1)–(3) at first approximation can be used to evaluate the bearing capacity of bending elements.

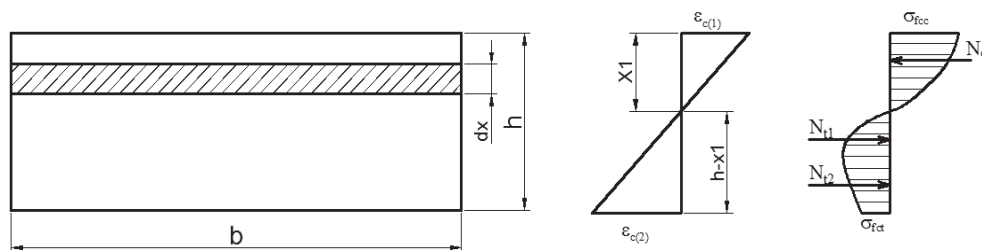

III. 2. Distribution diagram of deformation and compression cross cut of bending steel fiber concrete element

In III. 2 the distribution diagram of deformation and compression of bending element, which is reinforced by fiber, is shown. Bending element which can accept the element equals:

$$M = M_c + M_{t1} + M_{t2} \quad (4)$$

where:  $M_c$ ,  $M_{t1}$ ,  $M_{t2}$  – moments which are accepted by pressed and stretched zones according to the diagram relative to the neutral axis. The results of the experiments and calculations



have proved as will be shown below that in the stretching zone at the stage of utmost balance, the third part of the work of fiber concrete for stretching due to the diagram (Ill. 1) can not be realized.

The balance of inner stresses is provided under the implementation of the conditions:

$$N_c = N_{t1} + N_{t2} \quad (5)$$

At  $\varepsilon_{c(2)} \leq 0.002$ ,  $N_{t2} = 0$ .

Using the similarity of the triangles of the distribution diagram of deformation (Ill. 2) and known correlations of material resistance, it is possible to write for the compressed zone:

$$\begin{aligned} N_c &= \int \sigma_{fc} dF = \int_0^{x_1} f_{fcc} \sum_{k=1}^5 a_k \left( \frac{\varepsilon_c}{\varepsilon_{fcc,1}} \right)^k b dx = \\ &= \int_0^{x_1} f_{fcc} \sum_{k=1}^5 a_k \left( \frac{(\varepsilon_{c(1)} + \varepsilon_{c(2)})x}{h\varepsilon_{fcc,1}} \right)^k b dx = f_{fcc} b \sum_{k=1}^5 \frac{a_k}{k+1} \left( \frac{\varepsilon_{c(1)} + \varepsilon_{c(2)}}{h\varepsilon_{fcc,1}} \right)^k \left( \frac{\varepsilon_{c(1)}h}{\varepsilon_{c(1)} + \varepsilon_{c(2)}} \right)^{k+1} \end{aligned} \quad (6)$$

where

$$x_1 = \frac{\varepsilon_{c(1)}h}{\varepsilon_{c(1)} + \varepsilon_{c(2)}}$$

$$\begin{aligned} M_c &= \int \sigma_{fc} x dF = \\ &= \int_0^{x_1} f_{fcc} \sum_{k=1}^5 a_k \left( \frac{(\varepsilon_{c(1)} + \varepsilon_{c(2)})x}{h\varepsilon_{fcc,1}} \right)^k x b dx = f_{fcc} b \sum_{k=1}^5 \frac{a_k}{k+2} \left( \frac{\varepsilon_{c(1)} + \varepsilon_{c(2)}}{h\varepsilon_{fcc,1}} \right)^k \left( \frac{\varepsilon_{c(1)}h}{\varepsilon_{c(1)} + \varepsilon_{c(2)}} \right)^{k+2} \end{aligned} \quad (7)$$

Similarly by integrating for the stretching zone we receive:

$$N_{t1} = f_{fct} b \sum_{k=1}^5 \frac{a_k}{k+1} \left( \frac{\varepsilon_{c(1)} + \varepsilon_{c(2)}}{h2.5 \cdot 10^{-3}} \right)^k \left( \frac{2.5 \cdot 10^{-3} h}{\varepsilon_{c(1)} + \varepsilon_{c(2)}} \right)^{k+1} \quad (8)$$

$$M_{t1} = f_{fct} b \sum_{k=1}^5 \frac{a_k}{k+2} \left( \frac{\varepsilon_{c(1)} + \varepsilon_{c(2)}}{h2.5 \cdot 10^{-3}} \right)^k \left( \frac{2.5 \cdot 10^{-3} h}{\varepsilon_{c(1)} + \varepsilon_{c(2)}} \right)^{k+2} \quad (9)$$

$$N_{t2} = f_{fct} b h \left( 1.525 \frac{(\varepsilon_{c(2)} - 0.0025)h}{\varepsilon_{c(1)} + \varepsilon_{c(2)}} - 105 \frac{\varepsilon_{c(2)}^2 - 0.0025^2}{\varepsilon_{c(1)} + \varepsilon_{c(2)}} \right) \quad (10)$$

$$M_{t2} = \frac{f_{fct} b h^2 (0.7625(\varepsilon_{c(2)}^2 - 0.0025^2) - 70(\varepsilon_{c(2)}^3 - 0.0025^3))}{(\varepsilon_{c(1)} + \varepsilon_{c(2)})^2} \quad (11)$$

To reach  $\varepsilon_{c(2)} = 0.0025$ , exertions  $N_{t2} = 0$ . The exertions at the stretched zone at this level:

$$\begin{aligned} N_{t1} &= \int \sigma_{fct} dF = \int_0^{x_1} f_{fct} \sum_{k=1}^5 a_k \left( \frac{\varepsilon_c}{0.0025} \right)^k b dx = \\ &= \int_0^{x_1} f_{fct} \sum_{k=1}^5 a_k \left( \frac{(\varepsilon_{c(1)} + \varepsilon_{c(2)})x}{h \cdot 0.0025} \right)^k b dx = f_{fct} b \sum_{k=1}^5 \frac{a_k}{k+1} \left( \frac{\varepsilon_{c(1)} + \varepsilon_{c(2)}}{h \cdot 0.0025} \right)^k \left( \frac{\varepsilon_{c(1)} h}{\varepsilon_{c(1)} + \varepsilon_{c(2)}} \right)^{k+1} \end{aligned} \quad (12)$$

$$\begin{aligned} M_{t1} &= \int \sigma_{fct} x dF = \\ &= \int_0^{x_1} f_{fct} \sum_{k=1}^5 a_k \left( \frac{(\varepsilon_{c(1)} + \varepsilon_{c(2)})x}{h \cdot 0.0025} \right)^k x b dx = f_{fct} b \sum_{k=1}^5 \frac{a_k}{k+2} \left( \frac{\varepsilon_{c(1)} + \varepsilon_{c(2)}}{h \cdot 0.0025} \right)^k \left( \frac{\varepsilon_{c(1)} h}{\varepsilon_{c(1)} + \varepsilon_{c(2)}} \right)^{k+2} \end{aligned} \quad (13)$$

#### 4. Comparative analysis of test results

This analytical apparatus has been used to assess bearing capacity of steel fiber concrete elements of slab type within the sizes  $l = 700$  mm,  $b = 200$  mm,  $h = 30$  mm. The samples have been tested at operating execution 600 mm with the application of concentrated strengths at its thirds. The variations of percentage of fiber reinforcement of the volume  $\rho_{fv}$  and firmness of concrete-matrix  $f_c$  have been anticipated in the testing program. The results of the testing (table 1) have proved that the norms [1] in which the rectangular distribution diagrams of tension in compressed and stretched zones were accepted, don't allow to estimate precisely the bearing capacity of bending steel fiber concrete elements. Destructive bending moments  $M_{exp}$  have appeared to be essentially less than calculated  $M_{[1]}$  by the Norms [1]:

$$M_{[1]} = \frac{f_{fcc} \cdot f_{fct}}{f_{fcc} + f_{fct}} \times \frac{bh^2}{2} \quad (14)$$

Bending moments  $M_{theor}$  calculated under the proposed deformational method at 1...12% less than experimental ones. It is necessary to make a remark that the proposed deformational method allows to receive data about the pressed deformational state of the element during its work from the beginning of loading and up to its destruction. This way, for example, for the samples of first series SFB-1.1 (samples SFB-1.1.1, SFB-1.1.2 and SFB-1.1.3) have been received the following results which are given in the table 2 and in the Ill. 3. For the samples of these series as it is seen in the table 2, the maximum bending moment  $M_{theor} = 110.31$  Nm,  $\varepsilon_{c(1)} = 0.000657$ ,  $\varepsilon_{c(2)} = 0.003$ . Thus, as we see, at the utmost stage of destruction, deformations appear in the almost resilient pressed fibers. At the level of stretched fibers, the deformations agree with the descending branch of the diagram. The criterion of the destruction of a particular sample is the loss of balance of inner efforts (maximum at the diagram 'bending moment – flexures').

**Bearing capability of normal cuts of elements of slab type**

Sample name	$\rho_{fv}$ [%]	$f_{fcc}$ [MPa]	$f_{fct}$ [MPa]	$M_{exp}$ [Nm]	$M_{[1]}$ [Nm]	$M_{theor}$ [Nm]	$\frac{M_{theor}}{M_{exp}}$
SFB-1.1.1	0.7	25.4	2.05	112.17	170.72	110.31	0.98
SFB-1.1.2				110.5			0.99
SFB-1.1.3				113.5			0.97
SFB-1.2.1	1.25	26.35	2.33	143.0	192.66	139.25	0.97
SFB-1.2.2				146.5			0.95
SFB-1.2.3				151.5			0.92
SFB-1.3.1	1.8	28.00	2.62	169.0	215.62	158.16	0.94
SFB-1.3.2				176.5			0.90
SFB-1.3.3				173.0			0.91
SFB-2.1.1	0.7	36.33	2.36	130.0	199.44	126.18	0.97
SFB-2.1.2				129.5			0.97
SFB-2.1.3				129.0			0.98
SFB-2.2.1	1.25	37.54	2.68	173.0	225.12	162.22	0.94
SFB-2.2.2				169.0			0.96
SFB-2.2.3				166.0			0.98
SFB-2.3.1	1.8	38.51	3.02	198.0	252.04	181.11	0.91
SFB-2.3.2				209.0			0.88
SFB-2.3.3				187.0			0.97

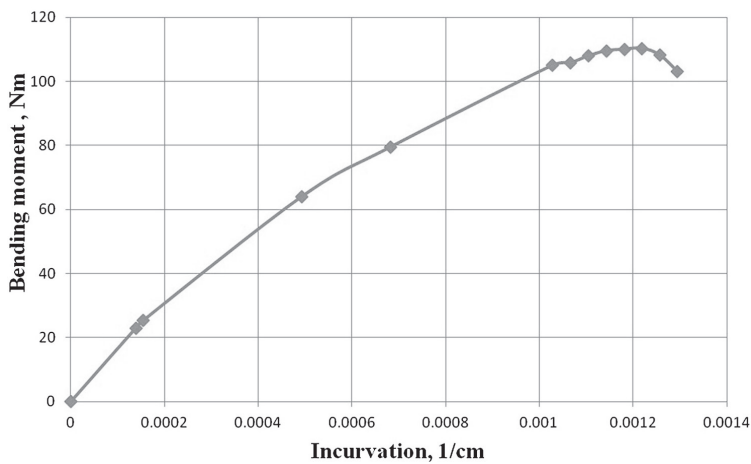

III. 3. The correlation of theoretical meanings of incurvation from bending moment for the pattern of series SFB-1.1

Table 2

**Calculation results of the pattern of series SFB-1.1**

$\varepsilon_{c(1)}$	$\varepsilon_{c(2)}$	$\chi = (\varepsilon_{c(1)} + \varepsilon_{c(2)})/h$	$\Sigma X = 0$	$M_{theor}$ [Nm]
0	0	0	0	0
0.00009	0.00032645	0.0001388	4.33008E-05	22.9838465
0.0001	0.0003638	0.0001546	0.001746577	25.349335
0.0003	0.0011796	0.0004932	0.001398572	64.027182
0.0004	0.0016458	0.0006819	0.000767925	79.4477685
0.000584	0.0025	0.001028	0.000299537	104.988299
0.0006	0.0026	0.0010667	1.31868E-05	105.790229
0.000615	0.0027	0.0011051	0.000173637	107.967217
0.00063	0.0028	0.0011433	0.000410186	109.523891
0.000644	0.0029	0.0011813	0.000983105	110.00438
0.000657	0.003	0.0012192	7.21837E-05	110.312265
0.000671	0.0031	0.0012568	0.00035582	108.217099
0.000683	0.0032	0.0012943	0.000317555	103.160216

It is necessary to mention that calculations were being done with the use of the tabular processor Excel. Received data can also be used to calculate flexures. To accomplish this the use of Excel is needed and the dot chart “flexure – bending element” must be approximated by the equation of a straight line or parabola and then the flexures must be determined by Mohr’s integral.

## 5. Conclusions

1. Deformational calculation method of steel fiber concrete elements has been proposed and appropriate mathematical apparatus have been elaborated.
2. Experimental meaning of bearing capacity of steel fiber concrete bending elements on the fiber from the sheet and theoretical significance calculated by the proposed method have shown quite a good convergence (Table 1).
3. Bearing capacity of steel fiber concrete bending elements calculated by the method [1] provided to the formula of which the experimental meanings of the firmness of steel fiber concrete at the extension and pressing is 28...54% higher than the experimentally received one. It is reasonable to make changes to the standard [1] to take the deformation method as the main method of calculation.

*This research work was performed as a part of the statutory investigations of AGH University of Science and Technology in Cracow no. 11.100.197.*

## References

- [1] *Конструкції будинків і споруд. Настанова з проектування та виготовлення сталефібробетонних конструкцій: ДСТУ-Н Б В.2.6-78: 2009*, Введ. в дію 01.01.2010, К.: Мінрегіонбуд України, 2009, 43.
- [2] *Сталефібробетонные конструкции: СП 52-104-2006*, Введ. в действие 01.09.2006, М.: ФГУП “НИЦ «Строительство””, 2007, 73.
- [3] Рак Н.А., *Методика расчета сталефибробетонных конструкций с использованием диаграмм деформирования сталефибробетона и стержневой арматуры*, Материалы третьего Международного симпозиума “Проблемы современного бетона и железобетона”, Минск, 09–11.11.2011, Режим доступа: <http://www.belniis.by>, 6.
- [4] Zilch K., *Die DafStb- Richtlinie Stahlfaserbeton*, Concrete Solutions 54. Betontage, K. Zilch., J. Lingemann, 09–11 Februar 2011, Neu-Ulm, Режим доступа: <http://www.mb.bv.tum.de>, 13.
- [5] Бабич Є.М., *Робота і розрахунок згинальних сталефібробетонних елементів*, Є.М. Бабич, С.Я. Дробишинець, Луцьк, Лнту 2012, 194.
- [6] Билозир В.В., *Образование и раскрытие трещин в нормальных сечениях изгибаемых сталефибробетонных элементов на фибре из листа*, автореф. дис. на соиск. научн. степени к. т. н.: спец. 05.23.01/ В.В. Билозир, М.: НИИЖБ, 1991, 24.
- [7] Бамбура А.М., *Експериментальні основи прикладної деформаційної теорії залізобетону*, автореф. дис. на здобуття наук. ступеня докт. техн. наук: спец. 05.23.01/ А.М. Бамбура, Харків: ХДТУБА, 2006, 39.
- [8] Glinicki M.A., *Beton ze zbrojeniem strukturalnym*, XXV Ogólnopolskie Warsztaty Pracy Projektanta Konstrukcji. Szczyrk, 10–13 marca, PZITB, Gliwice 2010, 279-308.

ROMAN KINASH\*, DMYTRO GLADYSHEV\*\*

## ANALYSIS OF FACTORS THAT INFLUENCE LONGEVITY AND SAFETY OF THE THIN-WALLED CONCRETE CONSTRUCTIONS

### ANALIZA CZYNNIKÓW WPŁYWAJĄCYCH NA TRWAŁOŚĆ I BEZPIECZEŃSTWO CIENKOŚCIENNYCH KONSTRUKCJI BETONOWYCH

#### Abstract

General data according to the conducted examination of some monolithic and precast steel concrete constructions of tower type, which were built by authors in Ukraine in the period from 2006 to 2011, has been described in this article. Conducted research has shown that unqualified implementation of separate works and factory defects in constructional elements are the basic reason of ruining the buildings and constructions. The materials of the analysis of the consequences from ruining buildings and constructions, and their elements from the defects during implementing building – assembly works, defects from technologic and random impacts are important in the way that from this analysis certain thoughts concerning making basic actions, which are directed on dissolution of different kind of defects to provide reliable operation of buildings and constructions, can be done.

*Keywords: cooling tower; pipes, silage, defects, operational capability*

#### Streszczenie

W artykule przedstawiono uogólnione wyniki badań niektórych monolitycznych i prefabrykowanych cienkościennych żelbetowych budowli wykonanych na terenie Ukrainy przez autorów w okresie od 2006 do 2011 roku. Badania wykazały, że głównymi przyczynami zniszczenia budowli są: zła jakość wykonania niektórych rodzajów prac i wady fabryczne elementów konstrukcyjnych. Bardzo ważne są wyniki analizy przyczyn zniszczenia budowli oraz ich elementów na skutek błędów w trakcie wykonania prac budowlanych, wad technologicznych i efektów losowych. W oparciu o tę analizę można przewidzieć kluczowe działania mające na celu wyeliminowanie różnych defektów w celu zapewnienia trwałości i niezawodności budynków i budowli.

*Słowa kluczowe: chłodnie kominowe, kominy, silosy, wady, trwałość*

\* Prof. Ph.D. Eng. Roman Kinash, AGH University of Science and Technology, Department of Geomechanics, Civil Engineering and Geotechnics; Lviv Polytechnic, Department of Architectural Constructions.

\*\* Ph.D. Eng. Vitalij Bilozir, Department of Civil Engineering and Architecture, Lviv National Agrarian University.



## 1. Introduction

One of the crucial problems of capital construction, which is the key problem in the issues of increasing the effectiveness of labor, its productivity, saving of labor and material resources, is the quality of construction. In this context we shouldn't forget about the influence of the human factor on the quality of construction.

Without profound improvement of construction quality, it is nonsense to implement all other objectives, thus they will strengthen the crisis matters in the sphere of national economy in general and have a ruining loss. If we don't prevent flaw (defects) in the construction, the consequences will be future planned repair and strengthening, changing the construction, accidents and early wear of buildings and constructions.

Most interminable constructions, which are being built 10–15 years, undergo repair and reconstructions even during the implementation work. A lot of them are still being built and used after the reconstructions, while others are forgotten and mothballed projects.

Nowadays, one of the serious objectives is the evaluation of operational capability and safety of holding constructions which are used more than 30 years [1, 2] or are under the conditions of mothballing or not due for a long time to unpredictable atmospheric and climatologic actions.

Critical and profound defects which essentially impact the durability of the constructions or make them functionally unusable can be identified using scientific technical convoy of work implementation concerning reconstruction and finishing building constructional sites. Clients don't always pay appropriate attention to the issues of scientific escort during work implementation of such kind.

Well-timed introduction of scientific convoy facilitates reducing the cost, fasten the work implementation and secure long term reliable exploitation of building sites.

Scientific convoy of the construction at this stage is in the provision and reconstruction of the building part of basic funds. It is getting actual, at each stage of the creation and operation of the building sites, to take into consideration all the aspects of their functioning. To do this, it is necessary to create a basis of experience in the work performance of such direction and develop a normative and methodological basis for its implementation.

Comparative analysis of the project solutions with the quality of implementation of building and assembly works, give us the ability to identify the influence factors, which are not taken into account during projecting of monolithic and prefabricated iron concrete constructions leading to the declining of their operational capability.

To date, the evaluation and increasing the longevity of monolithic, prefabricated and assembly-monolithic iron concrete constructions, which consist of thin-walled slips: towering constructions (chimneys, silages, spray coolers) built in the period of 60s and 70s, after 36–46 years of exploitation, are crucial and without doubt linked with the evaluation of construction quality.

## 2. Analysis of latest research and publications

The authors of the article have an experience in work implementation, especially concerning examination, evaluation of the technical state of building sites and elaboration of technical solutions regarding the strengthening of the constructions and buildings.

In general, this proves the expediency of wide implementation of scientific convoy during the reconstructions of technically complicated and especially responsible sites.

This article has generalized data due to the results of examinations of some thin-walled building sites of tower type (cooling towers, pipes, silages) which are made by the authors within the period from 2006 to 2011, specifically:

- iron concrete monolithic cooling tower station #5 Rivne Power Station [3, 4];
- iron concrete monolithic cooling tower station #1 Kyiv Combined heat and power plant – 6 [5, 6];

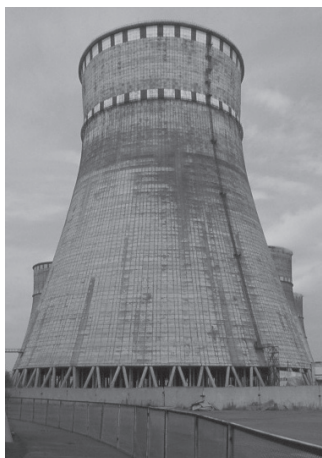

III. 1. Iron concrete monolithic cooling tower station #5 Rivne Power Station



III. 2. Iron concrete monolithic cooling tower station #1 Kyiv Combined heat and Power Plant-6

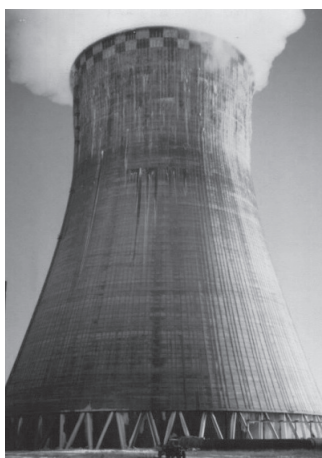

III. 3. Iron concrete monolithic cooling tower station #2 Zuyiv Thermal Power Plant



III. 4. Iron concrete prefabricated cooling tower station #4 Darnytsia Combined heat and Power Plant in Kyiv City



Ill. 5. Iron concrete monolithic pipe  $H = 120$  m  
Kyiv Station #2



Ill. 6. Iron concrete monolithic silages of the building #6 Open Joint Stock Company 'Mykolaiv Cement'

- iron concrete monolithic cooling tower station #2 Zyiv Thermal Power Plant [7, 8];
- iron concrete prefabricated cooling tower station #4 Darnytsia Combined heat and power plant in Kyiv city [9];
- iron concrete monolithic pipe  $H = 120$  m Kyiv station #2 [10];
- iron concrete monolithic silages of the building #6 Open Joint Stock Company 'Mykolaiv cement' in Lviv region [11].

### 3. Analysis of factors that influence x longevity and safety

#### 3.1. Iron concrete cooling towers

Building constructions of cooling towers of tower type are being used in exclusively pressed mode (alternating moistening and drying, freezing and melting, action of aggressive agents of counter waters and gases in the air) which causes their quick destruction.

Having investigated the actual state of iron concrete construction of some cooling towers in the Ukraine regarding their durability at the simultaneous impacts of all the above mentioned factors, the authors have found the following facts.

Actual class of concrete pillars ( $\varnothing 900$  mm) leaning colonnade of spray cooling towers of Rivne Power Station vary from  $B_f 32.5$  to  $B_f 55$  (coefficient of variation  $U_f = 3.25 \div 14.48\%$ ) within the project class B30, which affirms good monitoring of quality of their manufacturing. However, during instrumental research of cracking, the lengthwise shrink and cross-cut cracks in each pillar (Ill. 7) in depth immersion  $h_{cr}$  mainly up to 60 mm have been indentified, which result in steel reinforcement corrosion.

Actual class of concrete pillars ( $400 \times 500$  mm) leaning colonnade of cooling towers of Kyiv combined heat and power plant 6 vary within  $B_f 15$  to  $B_f 35$  (coefficient of variation  $U_f = 8.48 \div 31.62\%$ ) the project class B32.5, which signifies lack of quality for its manufacture. Changeability of firmness characteristics of concrete pillars leads to redistribution at the

lower cover contour of spray cooling towers and at the pillars of leaning colonnade (Ill. 8): 32÷36 mm for working steel reinforcement (according to the project 40 mm) and 17÷32 mm for transversal steel reinforcement (according to the project 30 mm). Besides, it was identified that during the assembly of beams of the lower supporting hoop on the pillars of leaning colonnade, a major constructional error has been made regarding the fact that beams were installed on the pillars 'dry' and 150 mm higher x than the farther monolithing of the knot (Ill. 9). This error was the reason for cracking in the cover of the spray cooling tower.



Ill. 7. The lengthwise and cross-cut cracks in pillars of leaning colonnade of cooling tower station #5 of Rivne Power Station



Ill. 8. Insufficient thickness of protective concrete layer and corrosion of transversal reinforcement in the pillar of leaning colonnade of cooling tower station #1 Kyiv Combined heat and Power Plant 6

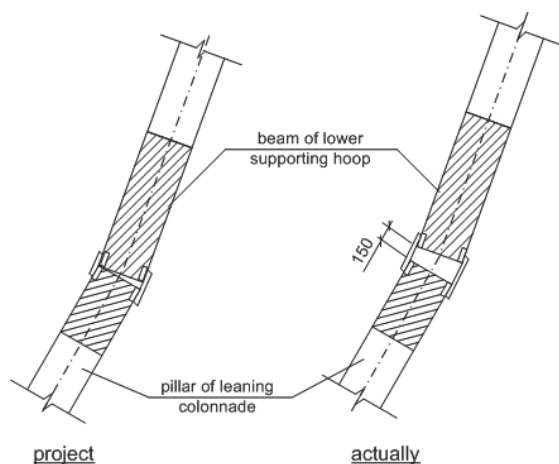

Ill. 9. Knot of pressing the pillars of leaning colonnade with iron concrete beams of lower supporting hoop of cover of cooling tower station #1 Kyiv Combined heat and Power Plant 6

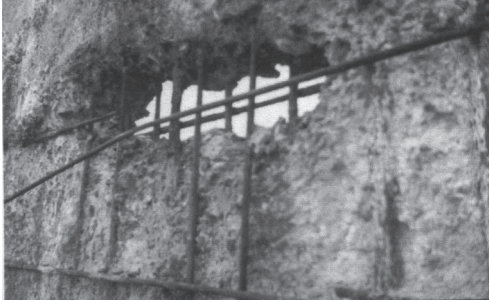

Ill. 10. Defective tier of concreting of cooling tower #2 at Zuyiv Thermal Power Plant (difference +122 m). Deviation of steps of working reinforcement. Absence of linking reinforcement in the net

According to the conducted research [7, 8] of the monolithic iron concrete cover of cooling tower #2 Zuyiv Thermal Power Plant, decent changeability of firmness characteristics of concrete has been approved regarding tiers of concreting. After identifying the most defective areas, the deviation from the project and the steps of working steel reinforcement has been determined, as well as the connection absence of reinforcement bars in the net (Ill. 10).

Actual class of concrete prefabricated iron concrete keyed slabs of the cover of cooling tower #4 of Darnytsia Combined heat and power plant varies between  $B_f 30$  to  $B_f 50$

(coefficient of variation  $U_f = 5,56 \div 20,87\%$ ) with the project class B25. Even though the actual class of concrete is larger than the designed one, changeability of coefficients of variation tell us about the lack of quality of its manufacturing. Furthermore, disparity of thickness of protective layers of concrete has been recorded:  $0 \div 14$  mm (Ill. 11) for steel reinforcement in the shelves of keyed slabs (according the project 18.5 mm) and  $10 \div 60$  mm (Ill. 12) for working steel reinforcement in keys of slabs (under the project 30 mm).



Ill. 11. Steel reinforcement corrosion and destruction of concrete of upper belt of firmness of the cooling tower #4 at Darnytsia Combined heat and Power Plant, protective layer of concrete is lower than designed

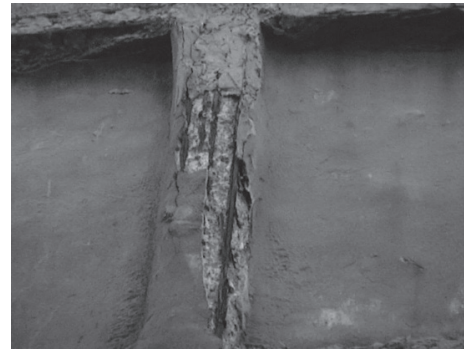

Ill. 12. Steel reinforcement corrosion and destruction of concrete of vertical ribs of prefabricated slabs of cover of cooling tower #4 at Darnytsia Combined heat and Power Plant, protective layer of concrete is lower than designed

Besides, it was observed that complicated details of adjacent slabs are linked with metal cover straps and the maximum designed thickness of the protective layer of concrete of laps is only 7 mm, which is not sufficient for the protection of the corrosion processes. Moreover, this protective layer is made of ordinary gunite which has not enough adherences to the material.



### 3.2. Iron concrete haze pipes – complicated long high-altitude engineering constructions

Quite often the defects of haze monolithic iron concrete pipes are mentioned because of low quality materials and constructions. It is necessary to say that defects which are linked with low quality protection from atmospheric and technological influences are stipulated by an attitude of neglect to the manufacturing of details and the constructions themselves, inefficient performance of the departments of surveillance of ‘the construction and exploitation of the buildings.

Having investigated the actual state of construction of iron concrete haze pipe  $H = 120$  m of Kyiv station #2 [10], the authors have found the following things.

Actual class of concrete monolithic stem of pipe at different levels of height varies within  $B_f 17.5$  to  $B_f 22.5$  (coefficient of variation  $U_f = 17,7 \div 29,2\%$ ) under the designed class B25. Insufficient firmness of concrete and decent changeability are due to insufficient monitoring of firmness characteristics of concrete and technologies of its stacking during the installation of stem pipes. Besides, during the process of examination, the spots of insufficiently compressed concrete have been determined, as well as sulfate corrosion of concrete and deflation (Ill. 13, 14).



Ill. 13. Insufficiently compressed concrete at the joint of tier of concreting



Ill. 14. Sulfate corrosion of concrete, filtration of moisture at the joint of concreting

To protect supporting stems of haze pipes from the impact of high temperatures and acids, protective fettlings are used which can be made of bricks, steel, polymer concrete or others. If the cracks appear in fettlings, burnout or other defects, destruction of the supporting stem can be doubly accelerated. During the examination of inner fettling of monolithic iron concrete pipes, the destruction of the brick wall of fettling with “through” penetrating? cracks has been identified (Ill. 15).

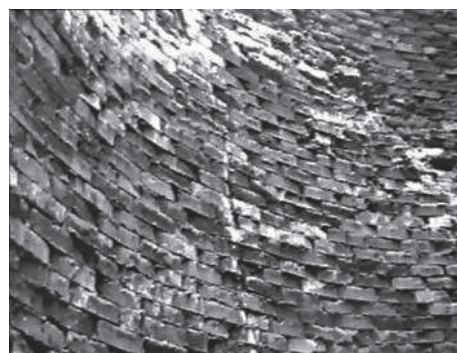

Ill. 15. Destruction of brick wall of fettling



### 3.3. Iron concrete monolithic silages – reservoirs to save friable materials

Conducted instrumental research [11] of monolithic iron concrete constructions of eight silages of building #6 at the factory Open Joint Stock Company ‘Mykolayv Cement’, after 42 year exploitation, has shown the following results.

Actual class of concrete of monolithic iron concrete constructions varies within B<sub>i</sub>10 to B<sub>i</sub>22,5 (coefficient of variation  $U_f = 9 \div 35,8\%$ ) when designed class is B15. Although the actual class of concrete in the majority of constructions satisfies designed significance, changeability of coefficients of variation indicates the insufficient quality of its manufacturing. In addition, according the investigation of the walls of silages, the disparity of thickness of the protective layer of concrete has been recorded – 10÷40 mm (due to the project 20 mm). Under the least thick protective layers, exfoliation is occurring and uncovering steel reinforcement as well (Ill. 16). Besides, the changeability of the steps of vertical and circular steel reinforcement of the walls of silages (up to 52.3% for vertical and up to 80% for circular steel reinforcement) has been noticed. All these point to low quality of control in all technological cycles of construction manufacturing.

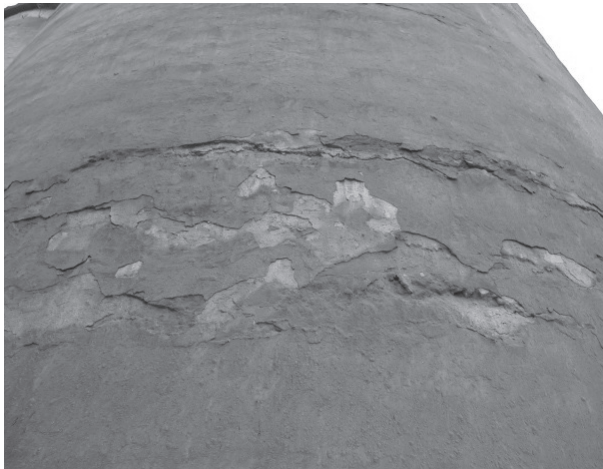

Ill. 16. Scaling of protective layer of concrete with stripping and corrosion of steel reinforcement on the surface of silage walls

Conducted research has shown that inferior performance of certain types of work and factory defects in constructional elements are the main issues of destruction of buildings and constructions. Losses from defects in x construction are happening because of the lack of appropriate monitoring over the following:

- using sub-quality construction materials supplied to the construction site, which are suitable to the requirement of the project,
- adherence to the allowances and aberrations from the standardized and designed solutions: lengths of elements and sizes of their diametrical cross cuts, thickness of the protective layer, pitches of steel reinforcement and other geometrical parameters,

- actual quality of implied output materials to produce concrete (cement, fillers, water) at all stages of technological process to ensure the necessary design firmness and homogeneity of concrete,
- work performance (installing concrete mixtures and their maintenance, quality of welded and other connections etc.).

#### 4. Conclusions

The information taken from the analysis of the consequences of destruction of buildings and constructions and their elements, from the defects during the implementation of building assembly works and flaws from technological and random impacts are important in a way that out of this analysis some thoughts, regarding the dissolution of different kind of defects to provide reliable operation of buildings and constructions, can be made.

Under the conditions when almost all governmental establishments which are responsible for quality assurance have been terminated in the Ukraine, the situation regarding the quality of construction is getting considerably worse and worse, which is not a good position anyway. The most dangerous tendency is the abrupt redundancy of the amount of building laboratories, geodesic and metrological services, and quality assurance engineers.

Building manufacture and its monitoring should not counteract each other, since more precise controlling doesn't guarantee the absence of defects, but the quality assurance of the building operation implementation can give the possibility to prevent, identify and eliminate the reasons which cause flaws, and the members of building manufacturing have to realize this by themselves.

The issues of construction quality have to be solved on a scientific basis. Quality control pertains not only to building materials, construction and other works, but also to all stages of building processes, particularly the technology of building manufacture and personnel qualification. The management activity as a whole, has to be directed to receive building precuts of certain quality and on time defect prevention, the further correction of which, would be quite an expensive issue.

In the case of the creation of mutual enterprises with foreign partners  $x$  in the country, these companies will face a new processes which our national building firms have never experienced so far. Thus, the functions of technical surveillance have become the functions of the representatives of foreign firms and in the manufacturing activity the issues of reaching high quality, which has been minor until recently, must be solved. This reality, forced to gain more profound knowledge of methods of how to assure high quality of building work performance according to the requirements of Building norms and rules, governmental building norms, governmental standards of the Ukraine, state standards, departmental norms, norms of foreign partners and other regulatory documents. The foreign partner doesn't take into consideration our difficulties and inability to find an agreement. In case we can't do something or refuse to implement any kind of work, another worker is hired and the building company loses  $x$  part of the desirable revenue.

The necessity to guarantee the customer and consumer appropriate quality and refund in case of inflicted loss can lead to the need to insure the quality which is analogical to the one which is stipulated by law, and includes the building expenses in the cost of insurance fees.

The conditions which guarantee quality must become an attestation of the contracting agency where its technical equipment must be taken into consideration as well as staffing levels of the appropriate type and qualification, availability of control-measuring equipment, devices, tools and presence of structural subdivisions of the organization, which are responsible for regulatory compliance and maintenance of governmental standards.

It is possible to introduce some actions, which are implemented in other foreign countries, where the institutes of quality and service of state building surveillance that provide services to municipal authorities are present, but in all these cases a new and more profound approach to protect the interests of government and customers of building products must be realized.

In the situation where the possibility of global modernization of economy is absent, the function of safe exploitation of old constructions is getting more important.

One of the promising directions to enhance the reliability of buildings and constructions from accidents, is the need of constant monitoring of their technical state. In order to prolong the periods of safe utilization of buildings and constructions, it is necessary to ban their further exploitation when they reach their deadline of normative exploitation. To allow continuation of the period of their exploitation, it is necessary to evaluate the residual resource of these buildings and constructions according to the conclusions of expert examination, using new efficient and technological solutions to extend their capability and appointment to the next term of their exploitation.

*This research work was performed as a part of the statutory investigations of AGH University of Science and Technology in Cracow No. 11.11.100.197.*

## References

- [1] *State building standards B.1.2-6-2006. The system of reliability and security assurance of construction projects. The basic requirements to buildings and constructions of mechanic resistance and stability*, Kyiv: Ministry of regional constructions of Ukraine, 2008, 15 (in Ukrainian).
- [2] *GOST27751-88. Reliability of building units and foundation. The main points concerning calculations*, Moscow: State standard of Soviet Union, 1988, 8 (in Ukrainian).
- [3] Gladyshev D.G., Gladyshev G.M., *The analysis of the phenomenon of concrete contraction by way of example of pillars of leaning colonnade of spray cooler*, Theory and practice of building: bulletin of Lviv National Polytechnic University #627, Lviv 2008, 44-49 (in Ukrainian).
- [4] Gladyshev D.G., Gladyshev G.M., *The influence of longitudinal shrink cracks on the way of operation of pillars of circular cut*, Resource saving materials, constructions, buildings and building sites: digest of scientific works of Lviv National Polytechnic University of water economy and management of nature #19, Rivne 2009, 109-115 (in Ukrainian).
- [5] Gladyshev G.M., Gladyshev D.G., Marakhovskiy K.V., *Analysis of examination results of leaning colonnade of steel concrete spray cooler # 1Kyiv CHP-6*, Resource saving

materials, constructions, buildings and building sites: digest of scientific works of Lviv National Polytechnic University of water economy and management of nature #5, Rivne 2000, 299-305 (in Ukrainian).

- [6] Gladyshev D.G., Gladyshev G.M., Butrynskiy I.Z., *The analysis of stress-strain state of steel concrete spray cooler #1 CHP6 in Kyiv*, Bulletin of Lviv territorial department of Building Academy of Ukraine #4/08, Lviv 2008, 30-35 (in Ukrainian).
- [7] Kosrun V.I., Machshenko A.N., Karmikov Y.Y., *The research of stress-strain state of steel concrete slip of spray coolers*, Bulletin of Donbass State Building and Architecture Academy #5(30), Makyeevka: DSBAA, 2001, 201-205 (in Ukrainian).
- [8] *The repair of steel concrete slip of spray cooler #2 Zyev Thermal Power Station. Technical report. "Spetzvysotremstroy"*, Makyeevka, Zygres 2002, 9 (in Ukrainian).
- [9] Gladyshev G.M., Gladyshev D.G., *The experience in examination, reinforcement and repair of slip of collapsible steel concrete biconical spray cooler*, Theory and practice of building: bulletin of Lviv National Polytechnic University #697, Lviv 2011, 68-75 (in Ukrainian).
- [10] Gladyshev D.G., Gladyshev G.M., Butrynskiy I.Z., *The determination of actual firmness of concrete according to the results of examination of shaft of steel concrete smoke pipe H = 120 m boiler #1, 2, 3 at Kyiv Station 2*, Bulletin of Lviv territorial department of Building Academy of Ukraine #4/08, Lviv, 2008, 35-41 (in Ukrainian).
- [11] *Measuring drawing and tool-making research of the designs of workshops of concrete silages of the factory 'Mykolayiv cement'*, Technical report. Scientific design firm "Reconstrproject", Lviv 2003, 400 (in Ukrainian).



JANUSZ RĘBIELAK\*

## DESIGNING OF STRUCTURAL SYSTEMS WITH APPLICATION OF PRINCIPLE OF SUPERPOSITION

---

### PROJEKTOWANIE SYSTEMÓW KONSTRUKCYJNYCH Z ZASTOSOWANIEM ZASADY SUPERPOZYCJI

#### Abstract

The paper refers to a method of statical calculation and to the forms of structural systems developed as results of an appropriate application of the principle of superposition. The point of the two-stage method of calculation of the statically indeterminate trusses is to do a suitable reduction of scheme of a given truss in order to obtain the scheme of a statically determinate truss together with a double application of simple methods used for these purposes and then application of superposition of obtained values of forces in appropriate members of the truss. Discussed also, are the procedures of shaping of selected forms of structural systems where the principle of superposition has been applied. It will be shown on suitable examples of the forms of a lenticular girder and of a system of combined foundation and a high-rise building.

*Keywords: method of statically calculation, structural system, designing*

#### Streszczenie

Przedmiotem artykułu jest metoda obliczeń statycznych oraz formy systemów konstrukcyjnych opracowane w wyniku odpowiedniego zastosowania zasady superpozycji. Dwuetapowa metoda obliczeń kratownic statycznie niewyznaczalnych polega na odpowiednim zredukowaniu schematu danej kratownicy do układu kratownicy statycznie wyznaczalnej i dwukrotnym zastosowaniu prostych metod obliczeń używanych do tych celów, a następnie superpozycji otrzymanych wartości sił w stosownych prętach. Omówiono także procesy kształtowania wybranych postaci systemów konstrukcyjnych, gdzie zastosowano zasadę superpozycji. Jest to przedstawione na przykładach odpowiednich form dźwigara soczewkowego oraz zespolonego systemu fundamentu i budynku wysokiego.

*Słowa kluczowe: metoda obliczeń statycznych, system konstrukcyjny, projektowanie*

---

\* Prof. D.SC. Ph.D. Eng. Arch. Janusz Rębielak, Institute of Construction Design, Faculty of Architecture, Cracow University of Technology.

### 1. Two-stage method of calculation of statically indeterminate trusses

The principle of superposition is constantly applied in numerous types of mathematic operations. Its suitable application constitutes the base of the two-stage method of the statically indeterminate trusses [1]. Procedure of an exact determination of the force values in this type of statical systems requires application of the appropriate calculation methods, which are taking into account differences of stiffness of members creating these structures. The aim of the proposed method is to make possible the initial and easy calculation of such type of trusses by means of the simplest possible way of the approximate determination of forces acting on their members. The method was worked out during the initial calculations of a statically indeterminate truss, which was a simplified scheme of a vertical cross-section of a certain group of the statically indeterminate spatial tension-strut structures [2] composed of cross-braces made as struts and tension members creating their external layers and vertical members. Structures built in this way have to be suitably pre-stressed, but if they will be overloaded by appropriately applied forces then the pre-stress effect disappears, results, that usually members of the upper layer are excluded from process of the force transmission. In this case it becomes a statically determinate truss and for want of the calculation of forces, one can apply the Cremona's, Ritter's or other suitable method [3–6]. A scheme of a simple procedure of the proposed method is presented in Ill. 1.

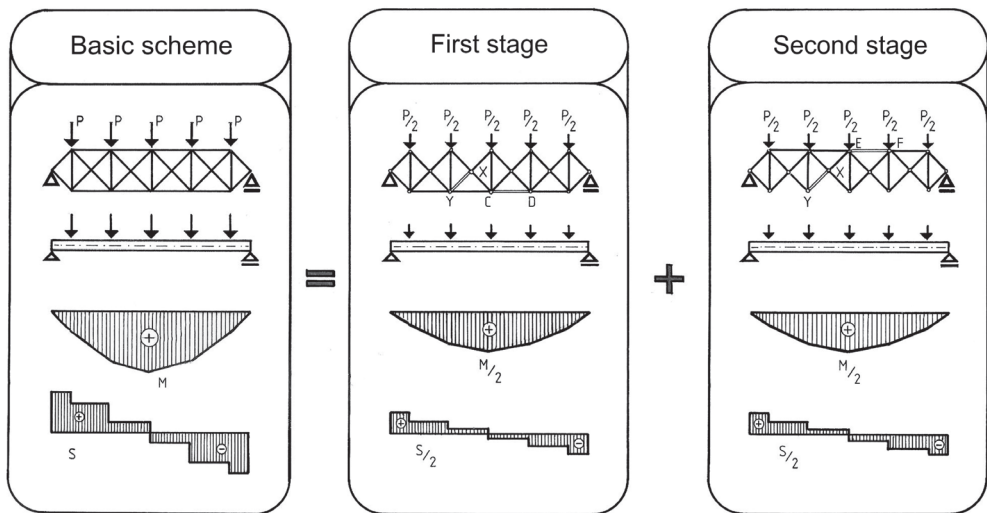

Ill. 1. Schemes of exemplary shapes of trusses calculated in successive stages of the proposed method

An exemplary shape of the basic flat statically indeterminate truss is loaded by forces  $P$  applied to nodes on the upper chord. Singular members of the external chords and the vertical posts are 1.00 meter in length. In the first stage of this method one should remove a number of e.g., the upper members, which equals the degree of statically indetermination of the basic truss and to apply to the same nodes the load of half the value of forces ( $P/2$ ) than applied



previously. In the second stage, one should reduce exactly the same number of members, but this time e.g. from the lower chord, due to which like in the first stage, it becomes the statically determinate truss and has to be loaded by forces of value  $P/2$  applied to the above mentioned nodes. In each stage the truss has the same clear span like the basic truss and the necessity of application of the twice smaller values of forces resulting follows from the general conditions of static equilibrium of the coplanar force system. Force values calculated in this way have to be summed up by means of appropriate application of the basic rules of superposition. The total values of forces acting in cross-braces are obtained by the sum of the values calculated in each stage for each particular member, see III. 2. The force values acting in members of the lower chord are determined in the first stage, while the sizes of forces acting on members of the upper chord are calculated in the second stage of the proposed method. Because the methods assigned to the calculation of the statically determinate systems are used in both stages, that is why the two-stage method gives as a result, the approximate values of forces. The method does not take into consideration the various stiffness of the members joined to the nodes in the way of force distribution. In spite of this circumstance, the differences between values of forces obtained in this method and force values calculated by application of suitable computer software are relatively little for the trusses built by means of members having not a greatly differentiated range of lengths. Due to this feature, the proposed two-stage method can be applied to the preliminary processes of the design of this type of structure. After taking into account the suitable numerical procedures together with the application of appropriate co-factors, this method can be applied to obtain very exact results from the statical calculations [2, 7].

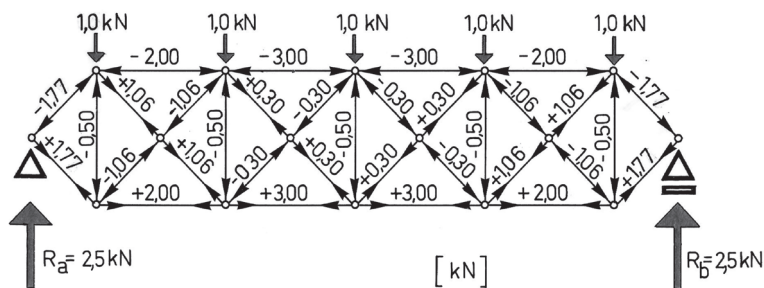

III. 2. Values of forces acting on members of an exemplary truss calculated by means of the two-stage method

## 2. Shaping of new types of lenticular girder

A group of new forms of the lenticular girder, as the plane and also spatial structural systems, has been shaped as result of the aim to design an assortment of simple, economic and easy to assemble structural systems of roof covers [8]. They should be built of compression members having a relatively small buckling length and of relatively long tension members. Moreover the new shape of such a girder, should be composed of typical members connected together in nodes having the simplest possible shape and to create structures, which can

take the load forces applied to them at optional directions on their main planes. The inspiration in the process of their design were trajectories of the main stresses in a free-end beam, see Ill. 3a. Schemes of examples of flat forms of such girders are presented in Ills 3b-d. Red lines indicate positions of the compression members while the arrangement of tension members is indicated by blue lines. Girders built in this way have to be pre-stressed, which can be done by means of e.g., suitable shortening of selected tension members [9, 10].

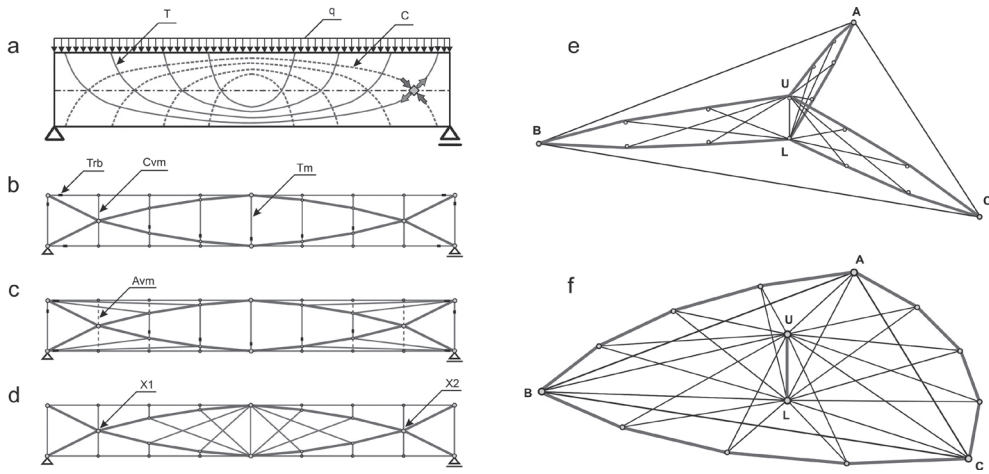

Ill. 3. Scheme of main vertical cross-section of a building designed by means of combined form of structural system

The structural concept described above has been adapted in the process of designing the spatial forms of the lenticular girders the selected shapes of which are shown in Ill. 3e and in Ill. 3f. These modules can be suitably connected together and can create double- or multi-layer bearing structures of the roof covers, particularly of large spans whose covers can be spaced over almost any optional shape of the base projection and can also take optional geometrical forms.

### 3. Shaping of the combined structural system of a foundation and of a building

The structure of a foundation, having transmitting loads from the building to the subsoil, has to be characterized by appropriate reliability and by a suitable set of technical conditions ensuring the safe foundation of the whole building on the ground having previously defined the parameters determining its load carrying ability. The proposed system of the combined foundation has been worked out mainly for objects located on the subsoil of small load capacity and in earthquake areas [10–14]. During the process of its design the principle of superposition was also applied [15] demonstrating an arrangement of component parts in the space of this system, as presented in a visual way in Ills 4a-d. In the narrow space between concrete elements (1) an upper set of the intermediate members, Ill. 4b, is supplemented



- [2] Rębielak J., Beranek W.J., Hobbelman G.J., *Wielowarstwowe struktury przestrzenne. Zagadnienia statyczne i geometryczne*, TH Delft, Afdeling der Bouwkunde, Vakgroep 4, UII – 396, September 1985, Raport Instytutu Architektury i Urbanistyki Politechniki Wrocławskiej, Nr I-1/P-332/1985.
- [3] Kolendowicz T., *Mechanika budowli dla architektów*, Arkady, Warszawa 1993.
- [4] Allen E., Zalewski W. and Boston Structures Group, *Form and Forces. Designing efficient, expressive structures*, John Wiley & Sons, Inc., Hoboken, New Jersey 2010.
- [5] Pyrak S., Szulborski K., *Mechanika konstrukcji dla architektów. Przykłady obliczeń*, Arkady, Warszawa 1994.
- [6] Przewłócki J., Górski J., *Podstawy mechaniki budowli*, Arkady, Warszawa 2006.
- [7] Rębielak J., *Metoda obliczania kratownic statycznie niewyznaczalnych w dwóch etapach*, XVII Międzynarodowa Szkoła Komputerowego Wspomagania Projektowania, Wytwarzania i Eksploatacji, Wojskowa Akademia Techniczna, Warszawa–Szczyrk, 2013, tom 2, 281-287.
- [8] Rębielak J., *Dźwigar soczewkowy*, Zgłoszenie patentowe, Urząd Patentowy Rzeczypospolitej Polskiej, nr P-385991, 2008.
- [9] Rębielak J., *Lenticular girder – structural shape and proposals for applications*, Evolution and trends in design, analysis and construction of shell and spatial structures, 50<sup>th</sup> Anniversary Symposium of the International Association for Shell and Spatial Structures (IASS), Valencia 2009, 256-257.
- [11] Rębielak J., *Koncepcje prętowo-cięgnowych systemów przekryć dachowych*, Inżynieria i Budownictwo, nr 1, 2011, 3-8.
- [12] Rębielak J., *Systemowy fundament zespolony*, zgłoszenie patentowe, Urząd Patentowy Rzeczypospolitej Polskiej, nr P.394745, 2011.
- [13] Rębielak J., *Combined form of structural system proposed for tall buildings*, Taller, Longer, Lighter – Proceedings of IABSE-IASS Symposium, London 2011, 308.
- [14] Rębielak J., *Budynek o zespolonej formie systemu konstrukcyjnego*, Czasopismo Techniczne, 2-A/2/2011, 303-308.
- [15] Rębielak J., *Koncepcja systemu konstrukcyjnego budynku wysokiego*, Inżynieria i Budownictwo, nr 1, 2012, 45-51.
- [16] Rębielak J., *A method of static calculation and shape of structural system developed by application of principles of superposition*, Lightweight structures in civil engineering – contemporary problems, Local seminar of IASS Polish Chapter, Warsaw 2012, 155-158.
- [17] Rębielak J., *System of combined foundation for tall buildings*, Journal of Civil Engineering and Architecture, Vol. 6, No. 12, December 2012, (Serial No. 61), 1627-1634.
- [18] Rębielak J., *Metody numeryczne w modelowaniu struktur przestrzennych. Kształtowanie systemów konstrukcyjnych budynków wysokich*, Archivolta, nr 1, 2013, 50-57.

AGNIESZKA SROKA-BURDZIŃSKA\*

## DETERMINANTS OF SHAPING AN ARCHITECTURAL FORM AND STRUCTURE IN WOODEN HALLS

### UWARUNKOWANIA KSZTAŁTOWANIA FORMY ARCHITEKTONICZNEJ I KONSTRUKCJI OBIEKTÓW HALOWYCH Z DREWNA

#### Abstract

In the paper, objects of modern hall construction of wood and mixed construction of primary structural systems are presented. Plane beam structures as well as trusses, post-and-beam construction, frame and arch construction are described in this paper. Cross-sectional dimensions and maximum span are estimated as well as information on the slope of roof surface is presented for the respective structural systems. The possibilities, restrictions and problems in shaping of architectural forms of the objects' structural systems also are presented in the paper.

*Keywords: glued laminated timber, glulam, transport limitations, girders, frames, arches, hall*

#### Streszczenie

W artykule omówiono obiekty nowoczesnego budownictwa halowego z drewna oraz rozwiązania mieszane o podstawowych układach konstrukcyjnych. Zaprezentowano płaskie ustroje belkowe i kratowe, słupowo-rygłowe, ramowe oraz łukowe. Dla odpowiednich układów konstrukcyjnych przedstawiono orientacyjne wysokości przekroju poprzecznego i maksymalne rozpiętości, a także informacje o pochyleniu połączy dachowej możliwej do osiągnięcia. Przedstawiono możliwości oraz ograniczenia i problemy, jakie należy uwzględnić w kształtowaniu form architektonicznych obiektów, ich układów konstrukcyjnych.

*Słowa kluczowe: drewno klejone, ograniczenia transportowe, dźwigary, ramy, łuki, hala*

\* M.Sc. Eng. Agnieszka Sroka-Burdzińska, Institute of Building Materials and Structures, Faculty of Civil Engineering, Cracow University of Technology.

## 1. Introduction

The first patents for glued-laminated timber (glulam) were issued more than a hundred years ago; however, Polish experience with this material is still quite poor. The use of this material in practice is restricted mainly to hall buildings functioning as sport, factory or sacral buildings.

In the era of modern emphasis on protecting the environment, wood is presently becoming the pivotal building material. The favorable ratio of the weight of timber to its stiffness and strength makes it possible to carry out the project with wide-span structures. Investors are choosing glulam more and more often as a solution, which at the same time gives the impression of being similar to solid wood. Moreover, it gives “psychological comfort” by introducing an warm and natural atmosphere to the object and its visual elegance and high aesthetic values of structure does not require additional finishing work. Timber is the material for which architects eagerly reach for as it allows for the realization of their creativity and imagination. Thus, the huge potential hidden in wood enables them to fulfill a wide variety of projects requiring uncommon and sophisticated ideas. In spite of this, the restrictions concerning the possibilities of shaping different forms of construction should be taken into account.

This publication is limited to give the characteristic features of the typical hall construction, most commonly observed in Poland, consisting of flat bearing systems placed perpendicularly to the longitudinal axis of the building.

## 2. Construction systems of a wooden hall

The classification of the glued-laminated timber with respect to the shaping of forms was made by Professor Wiesław Rokicki in [1]. Hall architecture, considered as the most typical and characterized by simple geometrical relations, has been placed as the primary construction of classification. It is implemented most frequently as a plane structural system such as: beam, truss, post-and-beam, frame and arch construction.

### 2.1. Plane structural system

The most frequently used flat systems with respect to the distance between particular flat systems (trusses, frames and arches) of about 4–10 m were presented in tables 1–5. Cross-sectional dimensions, economical and maximum span were estimated as well as information on the slope of roof surface was presented.

#### *2.1.1. Structural systems of beam and truss*

Structural systems of beam and truss are implemented as triple-hinged systems, consisting of two beams or trusses very often supported by a steel brace. The use of a brace is usually essential when the height of construction is lower than  $1/3$  of its span.



Table 1

## Beam and truss structures [4]

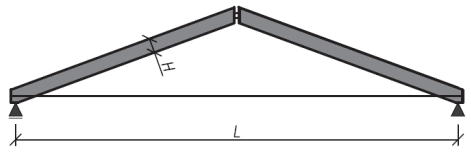
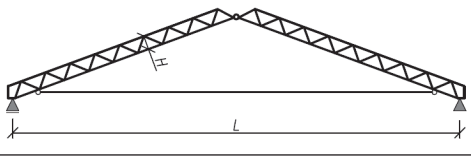
$L$ [m]	$H$	$\alpha$ [°]	Three-hinged structure, consists of two beams
without brace 15 ÷ 30 (maximum span 45 m) with brace 15 ÷ 40 (maximum span 50 m)	$\sim L/30$	$\geq 14^\circ$	
$L$ [m]	$H$	$\alpha$ [°]	three-hinged structure, consists of two trusses
without brace 15 ÷ 30 (maximum span 45 m) with brace 15 ÷ 40 (maximum span 60 m)	$\sim L/20$	$\geq 14^\circ$	
where: $L$ – the span of the structure $H$ – the depth of the member $\alpha$ – the roof pitch angle			

## 2.1.2. Post-and-beam constructions

They are most frequently used as construction of beam and truss girder. Constructions of this type can be implemented as mixed systems; glulam girders are based on steel or reinforced concrete columns, or masonry, concrete and reinforced concrete walls.

Table 2

## Post-and-beam constructions (beam girder of rectangular cross-section) [4, 5]

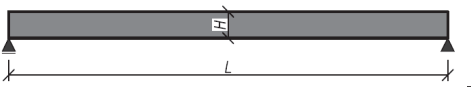
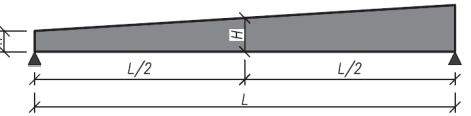
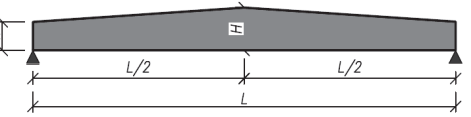
Rectangular cross-section constant over the entire length of the beam				
$L$ [m]	$H$	$\alpha$ [°]	with edges parallel	
< 30	$\sim L/17$	$\geq 3^\circ$		
Rectangular cross-section linearly variable along the beam length				
$L$ [m]	$H$	$h$	$\alpha$ [°]	single tapered beam
10 ÷ 35	$\sim L/16$	$\sim L/30$	5 ÷ 12°	
$L$ [m]	$H$	$h$	$\alpha$ [°]	double tapered beam
10 ÷ 30	$\sim L/16$	$\sim L/30$	3 ÷ 10°	

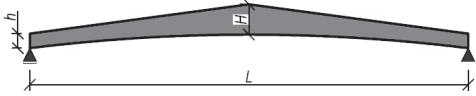
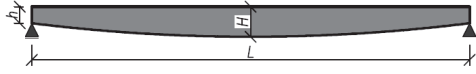
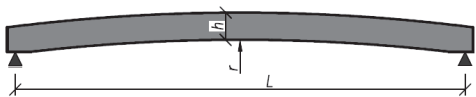
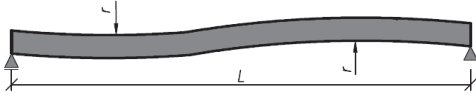
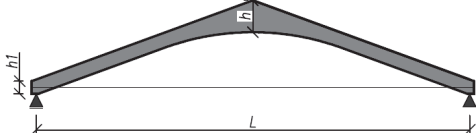
Beams with a curved lower edge and a variable cross sectional height				
$L$ [m]	$H$	$h$	$\alpha$ [°]	<b>Double tapered pitched cambered beams „boomerang”</b>
10÷20	$\sim L/16$	$\sim L/30$	3÷15°	
$L$ [m]	$H$	$h$		<b>„fish belly”</b>
20÷35	$\sim L/16$	$\sim L/32$		
Curved beams with rectangular cross sections with constant height				
$L$ [m]	$h$	$r$ [m]		<b>arch</b>
6÷30	$\sim L/17$	$\geq 7,5^*$		
$L$ [m]	$h$	$r$ [m]		<b>beam type „S”</b>
6÷30	$\sim L/17$	$\geq 7,5^*$		
Bowstring girders				
$L$ [m]	$H$	$h$	$\alpha$ [°]	<b>tie-beam „boomerang”</b>
10÷40	$\sim L/14$	$\sim L/34$	$< 12^\circ$	
where: $L$ – the span of the structure $H, h$ – the depth of the member $\alpha$ – the roof pitch angle $r$ – the radius of curvature				

Truss constructions can have different shapes. Currently, the ones which are most frequently used are timber and steel trusses, which give the effect of visual lightness of construction.

**Post-and-beam constructions (truss girders) [4]**

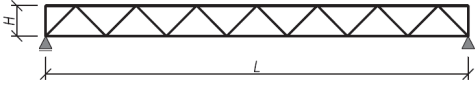
Truss girders			
$L$ [m]	$H$	$\alpha$ [°]	truss of parallel booms
30÷85	$\sim L/14$	$\geq 3^\circ$	
where: $L$ – the span of the structure $H$ – overall rise of the truss $\alpha$ – the roof pitch angle			

*2.1.3. Frame and arch constructions*

Due to the importance of the static scheme, we can distinguish between frames and arches: hingeless, single-hinged, double-hinged and triple-hinged in the ridge. The most commonly used are triple-hinged systems usually made of two elements connected by hinges in the ridge. Arches can be constructed in any shape; however, architects usually make it in the shape of a parabola.

Table 4

**Frames [4]**

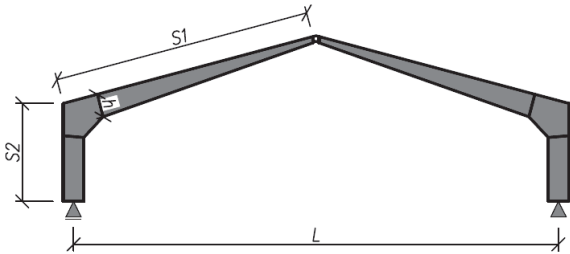
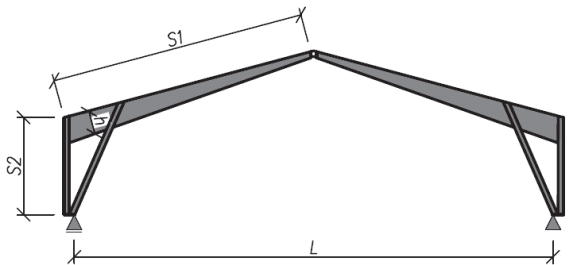
Triple-hinged frames			
$L$ [m]	$h$	$\alpha$ [°]	
15÷25	$\sim (S1 + S2)/13$	$\geq 14^\circ$	
10÷35	$\sim (S1 + S2)/15$	$\geq 14^\circ$	

15÷50	$\sim(S1 + S2)/15$	$\geq 14^\circ$	
<p>where:</p> <p><math>L</math> – the span of the structure</p> <p><math>h</math> – the depth of the member</p> <p><math>\alpha</math> – the roof pitch angle</p>			

Table 5

**Arches [4]**

Arches with solid rectangular cross section			
$L$ [m]	$H$	$f$	<b>double-hinged arch</b>
30÷100	$\sim 0.025L$	$\sim L/0.125$	
$L$ [m]	$H$	$f$	<b>triple-hinged arch</b>
20÷100	$\sim 0.025L$	$\sim L/0.17$	
Truss arches			
$L$ [m]	$H$	$f$	<b>hingeless , double-hinged, triple-hinged</b>
50÷120	$\sim 0,035L$	$\sim L/0,16$	
<p>where:</p> <p><math>L</math> – the span of the structure</p> <p><math>H</math> – the depth of the member</p> <p><math>f</math> – the rise of the arch</p>			

### 3. Possibilities and restrictions

The development of technology in the area of timber constructions, the invention of combining techniques and special water-proof glues on the basis of resin have made it possible to cross the biggest boundaries which had restrained the development of solid wood architecture. The length and thickness of tree bole is not a problem; however, the restrictions concerning the technological and production possibilities as well as transportation seem to be very important limiting factors. Quality restrictions are also very important, most manufactures have no technical approval to produce glulam elements above GL28h.

Polish manufacturers of glulam are still limited by production and technological restrictions caused by the excessively small capacity of machines and tools used in manufacture. Thus, Polish producers in comparison with manufacturers from abroad seem to have a rather poor record in terms of the length of elements offered by them as well as their capacity of manufacturing curved elements. Contractors very often import construction elements made of glulam from foreign manufacturers who are capable of making even 60 meter long elements. Moreover, the bending radii they achieve reach even 2 meters (for the thickness of 8 mm lamellae). Taking that into consideration, we assume that the key restriction for timber construction is the problem of transport. The longest girders transported across Poland are not usually longer than 45 meters. It must be remembered that transport with oversized vehicles is related to the necessity to obtain essential permits for transit, and the use of special tools and the use of special transportation, and if the length of the element exceeds 23 m, even pilot transit is necessary [3]. Not including transportation limitations at the stage of the project and at the same time designing oversized elements may hinder or even make it impossible to transport them which could result in the necessity of redesigning of the whole project.

For frame and arch systems, an important limiting factor is the width of the transport vehicle, these structures are usually implemented as triple-hinged and delivered to the construction site usually in two elements. Designing an arch that is not soaring or a girder of an overly small slope, can be the reason for significant transportation problems. The solution to transport problems of frame structures can involve designing of a stiff joint of the frame as connections can be implemented on the building site.

Transportation problems concern mainly solid-web elements. If the restriction does not allow for the use of solid-web construction, the solution to the problem may be the truss system. Such constructions can be supplied to the building site in segments. If the visual effect is not satisfactory, the truss can be finished (rimmed) by panels of glulam which give the effect of a solid beam. Obviously, because of aiming at maximal prefabrication of elements, the time of assembling and possible faults in constructing are reduced. However, we have to take into account the condition of Polish roads as it happens very often that transportation of oversized construction elements to small towns is impossible.

What seems to be a crucial limitation for shaping glued-laminated timber elements is the capability of bending. Despite the fact that production of bent elements in two or more dimensions is possible, this process is technically complex and expensive [2]. Usually, bending is performed in the vertical plane of the element. The most frequently implemented are elements of a similar curvature along the entire length, apart from those elements where the bending radius at the length of the beam is variable or partly curved and partly linear. The possibilities of shaping forms of structural elements are additionally limited by the value

of the minimum bend radius. The bending radius should not be too small in relation to the thickness of the lamella in order to reduce stress in the timber. The standard thickness for the lamella in glulam beams is 40 mm; the arched beams are made of timber with a thickness of 33 1/3 mm – for such thickness of the lamellas, the minimum radius, which it is possible to obtain, is 6 m. For smaller radius of bend, accordingly thinner timber should be used, which greatly increases the cost of production and the price of the final product; therefore, mainly elements of standard bend radius are produced.

#### 4. Conclusions

The possibilities of shaping forms of glued laminated timber are huge. Manufacturers or suppliers offering glued laminated timber, provide almost unlimited opportunities in shaping timber elements [6–9]. However, each architect or designer, who implements the construction of glued laminated timber, especially large span, must be aware of existing restrictions in particular transport; also technological and production limitations are important. A relevant barrier to the implementation of the construction of custom elements, offered by manufacturers of timber are economic considerations. Production of elements of non-standard forms, for example, less than the standard range of bending radii, significantly increases the cost of production of these elements and thereby increasing the cost of the investment.

*The work reported in this paper has been partially funded by the project L-1/115/DS/2013 Building compatible with Sustainable Development.*

#### References

- [1] Rokicki W., *Konstrukcja w aeurytmicznej architekturze*, Oficyna Wydawnicza Politechniki Warszawskiej, Warszawa 2006.
- [2] Maciejko-Grzeskowiak A., *Analiza przydatności konstrukcji z drewna klejonego o dużych rozpiętościach do realizacji form architektury współczesnej*, praca doktorska, Politechnika Wroclawska, Wrocław 2010.
- [3] Rozporządzenie ministra infrastruktury z dnia 26 kwietnia 2004 r. w sprawie pojazdów wykonujących pilotaż.
- [4] <http://www.svensktlimtra.se/> (*Limträ Guide*); access: 15.09.2013.
- [5] <http://konsbud.com/> (*Katalog rozwiązań konstrukcyjnych*); access: 15.09.2013.
- [6] <http://kondrew.com.pl/drewno-klejone.html>; access: 15.09.2013.
- [7] [http://www.piodo.pl/pl/aktualnosc/p\\_1182.htm](http://www.piodo.pl/pl/aktualnosc/p_1182.htm); access: 15.09.2013.
- [8] <http://www.drewniane-konstrukcje.pl/>; access: 15.09.2013.
- [9] <http://konsbud.com/showpage.php?pageID=15>; access: 15.09.2013.



TERESA ZYCH\*

## NEW GENERATION CEMENTITIOUS COMPOSITES WITH FIBRES – PROPERTIES AND APPLICATION

### FIBROKOMPOZYTY CEMENTOWE NOWEJ GENERACJI – WŁAŚCIWOŚCI I ZASTOSOWANIA

#### Abstract

The paper presents the properties of new generation cementitious composites with fibres, such as “bendable concrete” (ECC, Engineered Cementitious Composites) (plastic, not brittle but resistant to cracking material) with the addition of polyvinyl alcohol (PVA) fibres, high performance concrete (HPC) with glass fibres, reactive powder concrete (RPC) (characterized by ultra-high compressive strength, above 200 MPa) with short steel fibres. The detailed characteristics of the composition of the cement matrix and the role of fibres in the formation of the composite properties are described. Various applications of the composites as structural and architectural materials are also given.

*Keywords: polyvinyl alcohol (PVA) fibres, glass fibres, steel fibres, bendable concrete (ECC – Engineered Cementitious Composites), reactive powder concrete (RPC), high performance concrete, ultra-high performance concrete, architectural concrete, concrete durability, cracks*

#### Streszczenie

W artykule przedstawiono właściwości najnowszej generacji kompozytów cementowych z dodatkiem włókien, m.in. „betonów zginalnych” (ECC) (plastycznych, a nie kruchych przy zginaniu, odpornych na pękanie) z włóknami polialkoholowinyłowymi (PVA), wysokowartościowych betonów (HPC) z włóknami szklanymi, betonów z proszków reaktywnych (RPC) (cechujących się ultrawysoką wytrzymałością na ściskanie – powyżej 200 MPa) z krótkimi włóknami stalowymi. Szczegółowo scharakteryzowano skład matrycy cementowej oraz opisano rolę, jaką spełniają włókna w kształtowaniu właściwości kompozytu. Pokazano możliwości zastosowania kompozytów jako materiałów konstrukcyjnych oraz architektonicznych.

*Słowa kluczowe: włókna polialkoholowinyłowe (PVA), włókna szklane, włókna stalowe, beton zginalny (ECC), beton z proszków reaktywnych (RPC), beton wysokowartościowy, beton ultrawysokowartościowy, beton architektoniczny, trwałość betonu, rysy*

\* Ph.D. Teresa Zych, Institute of Building Materials and Structures, Faculty of Civil Engineering, Cracow University of Technology.

## 1. Introduction

The requirements given for concrete technologists by architects and constructors lead to the development of new types of concrete. The new generation **high performance fibre reinforced cement composites** (HPFRCC) presented in the paper: **reactive powder concrete** (RPC) with short steel fibres, **bendable concrete = engineered cementitious composite** (ECC) with **polyvinyl alcohol (PVA)** fibres, **high performance concrete** (HPC) with glass fibres are the effect of the modification of plain (conventional) cement concrete throughout many years.

During the past thirty years there has been considerable progress in concrete technology. Through the reduction of typical drawbacks of plain concrete (cement matrix microcracks resulting from shrinkage or excessive loading, destruction of the material in a brittle manner, as well as high open porosity, and thus high penetration of water and aggressive agents, low frost resistance) new types of cement composites have been obtained [9, 24]. The following changes in the composition of concrete have been introduced to provide better mechanical properties and durability: the significant reduction of water-cement (w/c) ratio, the application of cement binder with the highest strength, the filling of the intergranular space with small particles (e.g. silica fume) to obtain low porosity, the limitation of the size of inclusion grains (e.g. not applying coarse aggregate) in order to obtain a material of much higher homogeneity, as well as the addition of new generation admixtures (e.g., highly effective superplasticizers – polycarboxylates) to achieve good workability of composites [6, 24]. Furthermore, various types of fibres have been used in order to strengthen the matrix by the reduction of all kinds of cracks and the improvement of strength properties due to the interaction of fibres in the transfer of tensile stresses [4, 7, 11] (Ill. 1).

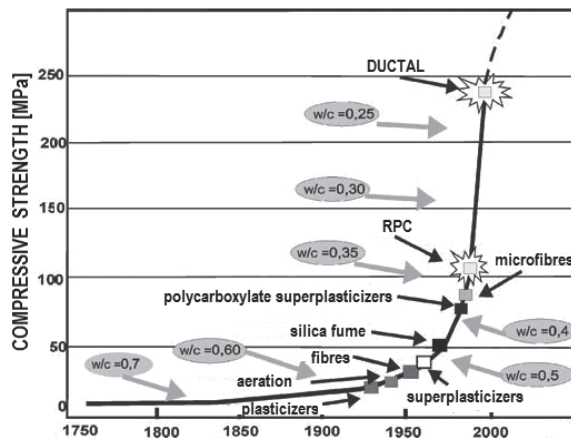

Ill. 1. Generalized curve of concrete development [9]

In the eighties of the 20th century, the following types of concrete were invented: **self compacted concrete** (SCC) characterized by very good workability and the lack of necessity

of intentional concrete mixture compaction (due to new generation superplasticizers), **high performance concrete** (HPC) having not only high compressive strength (classes above C50/60 according to PN-EN 206-1 standard [46]), but also other properties of higher level (mainly low permeability for liquid and gaseous environmental media, high resistance to abrasion due to low value of water-cement ratio, the application of silica fume and new generation superplasticizers etc.) [3, 9].

The search for new types of high-performance concretes led to the determination of the composition of **reactive powder concrete** (RPC) and **bendable concrete = engineered cementitious composite** (ECC) in the 90s of the twentieth century. RPC with short steel fibres and ECC with polyvinyl alcohol (PVA) fibres constitute a group of **high-performance fibrous cementitious composites**, characterized by, apart from high durability, ultra-high compressive strength in the case of RPC (e.g., of 200 MPa) and ultra-high ductility in the case of ECC [18, 39]. Experimental studies concerning these composites are still carried out by research centres and universities from different countries around the world, and the latest research achievements are presented at international conferences: “International Symposium on **Ultra-High Performance Fibre Reinforced Concrete**” – “**UHPC**” (2009, 2013 – Marseille, France) [39], “International RILEM Conference on **Strain Hardening Cementitious Composites**” – “**SHCC**” (2009 – Stellenbosch, South Africa, 2011 – Rio de Janeiro, Brazil, 2014 – Dordrecht, the Netherlands), etc. In the case of **RPC (UHPC)** the leading countries in the world, both in research work and implementations are the USA, Canada, France, etc. [5, 15, 49, 52, 56], and in the case of **ECC (SHCC)**, the USA, Japan, South Africa, Czech Republic, the Netherlands, etc. [17, 22, 55].

The paper contains up-to-date information on new generation high-performance fibre reinforced cementitious concretes, their composition, properties and the range of application as structural and architectural materials.

## 2. Reactive powder concrete

**Reactive powder concrete (RPC)** is one of the most advanced mineral building materials. The composite belongs to the group of **ultra-high performance concretes (UHPC)**, i.e., concretes with 28-day compressive strength of above 150 MPa (typically 200 MPa) (high-performance concretes of lower strength: High-Performance Concrete /HPC/ with compressive strength of 60–120 MPa, Very High Performance Concrete /VHPC/ with compressive strength of 120–150 MPa) [7, 13, 17].

The composition of reactive powder concrete was developed in the early 90s of the 20th century, after a decade of research in the laboratory of **Bouygues** (a French company, which designs and constructs structures) [33, 34]. Concrete with a compressive strength of 200 MPa and flexural strength of 40 MPa was then obtained. The result of further research, carried out since 1994 by Bouygues together with the French companies: **Lafarge** (the manufacturer of concrete) and **Rhodia** (the manufacturer of building chemistry), was a patent for RPC. The innovative material was called **Ductal®** to emphasise in its name that the material is characterized not only by ultra high strength, but also by **ductility** [13, 24, 31, 32, 35, 38].

Nowadays, apart from Ductal®, RPC-type composites, offered as commercial products are: **BSI/Ceracem®** (**B**éton **S**écial **I**ndustriel), produced by **Eiffage** (France)/**Sika**

(Switzerland), **BCV®** (**B**éton **C**omposite **V**icat), produced by **Vinci/Vicat** (France), etc. [35, 39]. **Ductal®** is most commonly used in the United States, Australia and Asian countries.

Reactive powder concrete is a fibre reinforced cementitious composite made from powders: the highest class of Portland cement (CEM I 52.5 R), silica fume, powdered quartz (0/0.1 mm), quartz sand (0/0.6 mm) as well as water, superplasticizer and the fibrous reinforcement in the form of short and very thin steel fibres (Ill. 2). RPC does not contain coarse aggregate and the average size of coarse particles is 200  $\mu\text{m}$  (sand grains). Determining the composition of the composite is a complex problem, which involves not only the assumption of the appropriate ratio between the components with different grain size (in order to get possible maximal packing of the granular component), but also in their appropriate selection as to their physical and chemical properties [3, 7, 38]. The example of the proportion of the components (by mass) is as follows [6, 43]: cement: silica fume: ground quartz: sand: water = 1:0.2:0.34:0.81:0.24. A superplasticizer is used in the amount of about 2% of the weight of the cement. RPC is a self-leveling concrete, which does not require compaction. RPC is mostly manufactured in a concrete plant and is transported to the construction site.

**CEM I 52.5R Portland Cement** (with the particle diameter /size/ of **1–100  $\mu\text{m}$** ) is used in the amount of about 700  $\text{kg}/\text{m}^3$ , which is more than double than in the case of ordinary concrete.

**Silica fume** (a by-product obtained in the metallurgical process during the production of metal silicon, ferro-silicon and other alloys) is a component of concrete of the smallest size. Microscopic grains of spherical shape, which are almost pure, amorphous  $\text{SiO}_2$ , have a diameter of less than 1  $\mu\text{m}$  (**0.1–1  $\mu\text{m}$** ). The average grain size is **0.2  $\mu\text{m}$**  (cement particles are 100 times greater) [13, 28, 29]. Silica fume is characterized by an enormous surface area (from 130 000 to 200 000  $\text{cm}^2/\text{g}$  measured by the BET method) [29]. A very large surface area of silica fume particles enables the adsorption of water and concrete mixture containing this additive hardens very quickly, thus the mix cannot be used without superplasticizers. Silica fume creates the microstructure of the cement matrix by physical (as a microfiller) and chemical interaction. The essential role of silica, due to its granulation, is to fill the empty spaces between the larger grains of cement and aggregate. In order to get the maximum possible packing of granular components, silica fume is applied in the amount of 20% of the weight of the cement. Silica fume results not only in sealing, but also in strengthening the cement matrix. As a result of the chemical reaction of silica fume ( $\text{SiO}_2$ ) with calcium hydroxide  $\text{Ca}(\text{OH})_2$  (contained in cement paste) hydrated calcium silicates ( $\text{CaO-SiO}_2\text{-H}_2\text{O}$ ) are formed, i.e. the additional amount of **C–S–H** (Calcium – Silicate – Hydrate) phase [43].

**Quartz flour=Ground quartz** (=Quartz powder=Silica flour) (with the particle diameter of **0.1–100  $\mu\text{m}$** ) complements the fine sand fractions and therefore the granulation of the ground quartz should be close to the cement's granulation. When the quartz grains are very fine (smaller than 5 $\mu\text{m}$ ), the quartz (known for its low reactivity to  $\text{Ca}(\text{OH})_2$ ) may react with  $\text{Ca}^{2+}$  ions. The amorphous silica (silica fume)/crystalline silica (ground quartz) ratio should be selected in such a way that the forming of the C–S–H phase would take place by the C/S mole ratio within the range of 0.83 to 1.0 [37, 38].

**Quartz sand** (Silica sand) (with the particle diameter of **150–600  $\mu\text{m}$** ) plays the role of a micro-aggregate [3, 37]. Granulation of quartz sand ought to be continuous to provide the tightness of the stack of particles when the micro-aggregate is mixed with ground quartz. Quartz sand is added in almost the same amount as the cement fraction.

**Water/cement ratio** is very low and is usually about 0.2 (lower than 0.28). Such a low amount of water (in particular at high temperatures of curing) reacts completely with the cement, which limits the possibility of formation of capillary pores effected by the evaporation of non-reacted water. The use of such low w/c ratio is possible by the application of new generation polycarboxylate superplasticizers (Ill. 1). The cement particles that are not totally hydrated serve as microfillers (Ill. 2) [7].

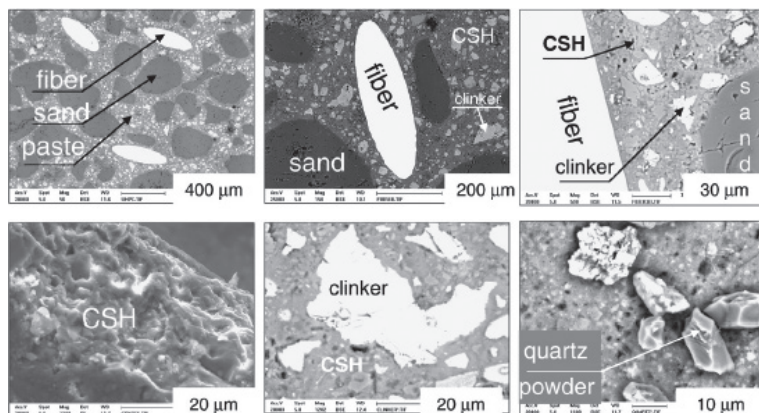

Ill. 2. RPC – microstructure (SEM images) [37]

**Superplasticizer** is added both because of the very low water-cement ratio and the presence of a fibrous inclusion that worsens workability.

**Steel fibres** (fibrous reinforcement of concrete), typically having a diameter of **0.2 mm** and a length of 12 mm (with dimensions not exceeding these values to ensure the homogeneity of the composite) are used in the amount of **2%** by volume ( $150 \text{ kg/m}^3$ ). Fibre properties are given in Table 1. The presence of fibres (taking over the tensile stresses) is intended to improve resistance to cracking of reactive powder concrete, which is a very brittle material [10, 45, 52].

**Heat-moisture treatment** of concrete (curing in a water vapour environment at higher temperatures) is applied for improvement of the microstructure of the cement matrix. The process, conducted in atmospheric pressure conditions (low-pressure treatment) or in autoclave (high-pressure treatment) affects the improvement of strength properties of the composite [1, 3, 6, 21, 37, 38]. The low-pressure heat treatment at the temperature of  $90^\circ\text{C}$  (in water vapour) [24] is specific in the acceleration of the cement hydration process and induction of pozzolanic reactivity of residual components, and then the amount of the C–S–H phase formed. It also affects positively the limitation of autogeneous shrinkage of the material which contains a substantial amount of binder [3, 6, 21]. The high-pressure heat treatment (steaming in the autoclave, e.g. for 2 days), conducted at the temperature of  $250^\circ\text{C}$ , may lead to the formation of crystalline hydrated calcium silicates (e.g. tobermoryte  $\text{C}_5\text{S}_6\text{H}_5$  and ksonotlite  $\text{C}_6\text{S}_6\text{H}$ ), which improve the mechanical properties of RPC [3, 38].

Table 1

Properties of fibres [7, 10, 23, 41, 53, 55]

Type of fibre	Diameter [mm]	Density [g/cm <sup>3</sup> ]	Tensile strength [GPa]	Modulus of elasticity [GPa]	Elongation [%]
Steel	0.20	7.8	2.2	210	3–4
Polyvinyl alcohol (PVA)	0.04	1.3	0.9	26	6–10
Glass (AR-Alkali Resistant)	0.01	2.8	2.2	70–80	0.5–4.0
Cement paste	–	2.0–2.2	0.003–0.006	10–30	–

RPC is characterized not only by ultra-high compressive strength (200 MPa), but also by other advantageous mechanical properties: flexural strength – above 20 MPa (Ill. 3), tensile strength – about 10 MPa (see Table 2), high resistance to impact and abrasion [39, 40, 47]. The research on the behaviour of RPC during tension has shown the formation of a large number of tiny cracks, but not big ones. Moreover, in RPC subjected to bending, no single, wide cracks have been observed (which do occur in the case of brittle composites), but many dispersed microcracks. Tiny cracks do not adversely affect the durability of the composite [10, 13]. RPC shows the increase in load capacity after the first crack during bending, i.e. hardening after cracking and therefore it belongs to the group of “deflection-hardening” composites (compare Chapter 3, Ill. 3, 16) [13].

Table 2

Properties of plain concrete, RPC, ECC, HPGRC [20, 21, 34, 35, 39, 40, 41, 47, 52, 53]

Property	Plain concrete	RPC	ECC	HPGRC
Compressive strength [MPa]	till 50	150–200	60–70	70
Tensile strength [MPa]	1–3	5–10	4–6	9
Strain during tension [%]	0.01	0.02–0.06	3–5	0.6
Modulus of elasticity [GPa]	15–40	50–60	20	17

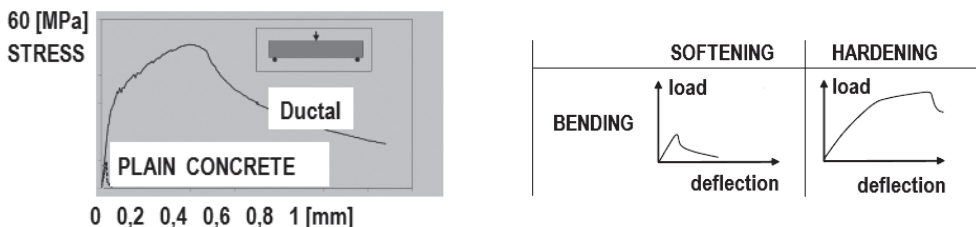

Ill. 3. Behaviour of RPC during flexion – hardening after cracking (“deflection-hardening”) seen on the “stress-deflection” diagram [3]

Tight microstructure of RPC (open porosity: RPC: 1.5–6%, plain concrete: 12–16%; oxygen permeability: RPC < 10<sup>-19</sup> m<sup>2</sup>, plain concrete: 10<sup>-15</sup>–10<sup>-16</sup> m<sup>2</sup>; portlandite content:



RPC: none, plain concrete:  $76 \text{ kg/m}^3$  [34]) prevents the penetration of any corrosive agents (harmful liquid and gaseous media) into concrete, and thus provides durability of the material. Reactive powder concrete, combining **ultra-high strength properties with durability**, may be suitable for buildings exposed to various aggressive environmental conditions.

Moreover, the structure of concrete is constantly being sealed. In RPC **self-healing (self-sealing)** of microcracks has been observed. The particles of cement, which are not totally hydrated because of the use of a small quantity of water (w/c ratio of about 0.2), significantly improve material durability as they may potentially continue the hydration process whenever any micro-cracks appear (at the appropriate ambient humidity) [24]. The image of self-healing of microcracks is presented in Ill. 4a.

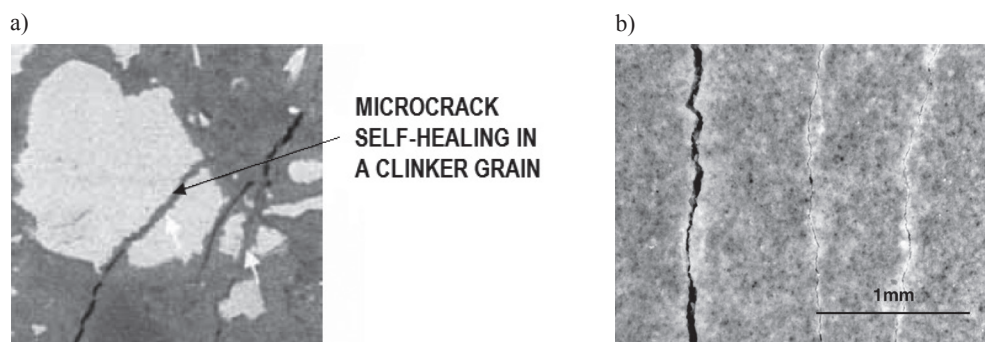

Ill. 4. Self-sealing of microcracks: a – RPC composite, b – ECC composite [23, 42]

Advantageous properties of reactive powder concrete have determined its application as a **structural** material from which are made:

- prefabricated structural elements (beams, girders, slabs, columns etc.), e.g. elements of footbridges (Ill. 5, 6) [31, 39] (these elements are slender and light as opposed to previously applied large, massive and heavy elements made of other materials),

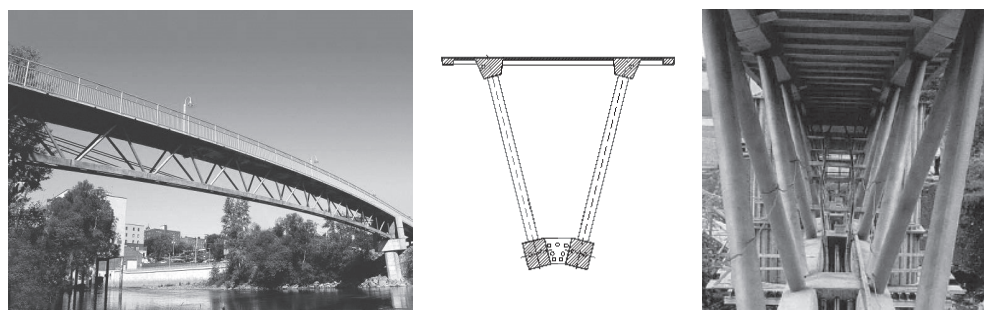

Ill. 5. Application of RPC (Reactive Powder Concrete) – “Ductal®”: “Sherbrooke footbridge” – the first structure in the world made of RPC (span: 60 m) (3 cm thick RPC slab, steel-concrete composite elements – RPC confined in steel tubes) – prestressed concrete structure, Sherbrooke, Canada, 1997 [24, 52]



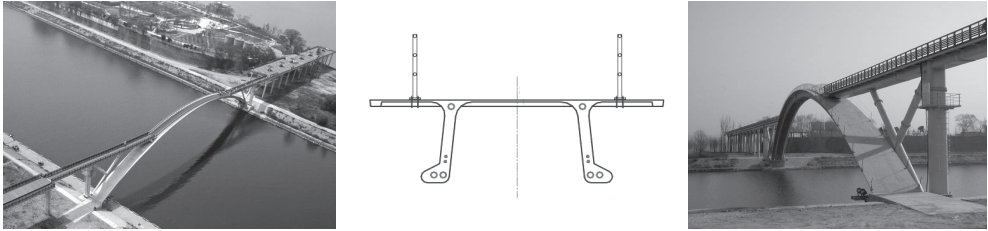

III. 6. Application of RPC (Reactive Powder Concrete) – “Ductal®”: “Seonyu footbridge” (“Footbridge of Peace”) – the longest footbridge in the world made of RPC (span: 120 m) (3 cm thick slab,  $\pi$ -shaped cross-section of the arch) – prestressed concrete structure, Seoul, South Korea, 2002 [24, 52]

- elements of marine structures, hydraulic structures, etc., exploited in harsh environmental conditions, exposed to abrasion [31],
- roof shells (also with a complicated geometrical shape) such as railway (III. 7), car (III. 8), bus and cycling (III. 9) sheds,
- pipes [24].



III. 7. Application of RPC (Reactive Powder Concrete) – “Ductal®”: Shawnessy Light Rail Train (LRT) Station (RPC precast elements: ultra-thin (2 cm) curved roof shell, columns), Calgary, Canada, 2004 [40]



III. 8. Application of RPC (Reactive Powder Concrete) – “BSI/CERACEM®”: shed: Millau Viaduct Toll Gate, Millau, France, 2004 [49, 56]

The world’s first structure made of RPC (Ductal®) is a footbridge in Sherbrooke in Canada, built in 1997 (III. 5) [1, 5, 13]. The footbridge is a prestressed structure with the

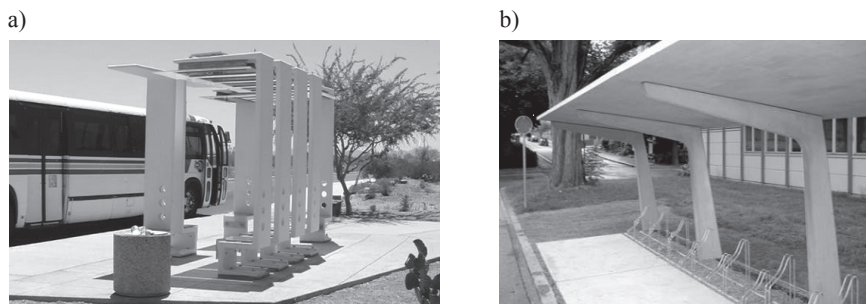

III. 9. Application of RPC (Reactive Powder Concrete): sheds: a – bus shelters, Tucson, Arizona, USA (“Ductal®”) [52], b – bicycle shed, Bern, Switzerland (“BCV®”) [47]

span of 60 m, made of prefabricated elements. RPC was used as a filler of steel tubes and to construct the bridge deck bottom which was 3 cm thick [53]. Nowadays the world’s thinnest coating made of RPC (2 cm thick) is a part of the roof (designed as Catalan surface) at Shawnessy Boulevard railway station in Calgary, Alberta, Canada (III. 7).

**Reactive powder concrete** is also applied as an **architectural** material from which are constructed:

- prefabricated cladding panels and façade sun-shades (with various textures – III. 11b), e.g. façade elements of bus station buildings (III. 11a), airport buildings (III. 12b), apartment and office buildings (III. 10, 12a), etc. [24],



III. 10. Application of RPC (Reactive Powder Concrete) – “Ductal®”: façade panels (curtain wall system) (ultra-thin), “The Atrium”, Victoria, Canada, 2010 [12, 52]

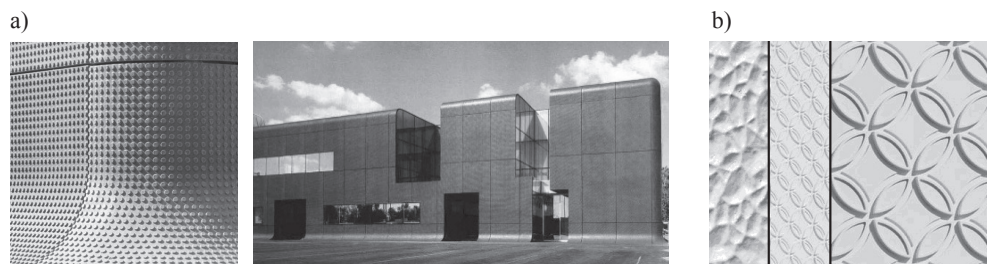

III. 11. Application of RPC (Reactive Powder Concrete) – “Ductal®”: a – façade panels (“LEGO® style” texture), Thiais RATP (Régie Autonome des Transports Parisiens) Bus Centre building, Thiais (near Paris), France, 2007 [12, 32, 50, 52], b – various textures of cladding panels [52]

a)



b)



III. 12. Application of RPC (Reactive Powder Concrete) – “Ductal®”: façade panels – sun-shades (“double-skin façade”=“building envelope”), a – Plescop City Hall, Plescop, France, 2010, b – Rabat-Salé Airport building, Rabat, Morocco, 2011 [52]

- prefabricated façade elements with complicated shapes (III. 13) [32, 51, 52],
- pathways (III. 14),
- elements of interior furnishings: benches, tables (III. 15b), floor tiles, etc.,
- elements of parks and gardens “small architecture”: plant pots (III. 15a), urban and garden furniture, etc. [32],
- repair layers.

a)

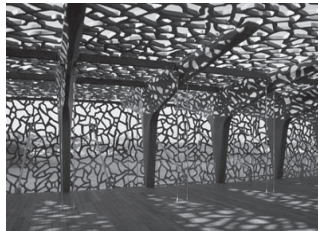

b)



III. 13. Application of RPC (Reactive Powder Concrete) – “Ductal®”: cladding (façade) elements, a – Museum of the Civilisations of Europe and the Mediterranean (MuCEM), Marseille, France, 2013 [51], b – housing block, ZAC Paris Rive Gauche, Paris, France, 2007 [52]



III. 14. Application of RPC (Reactive Powder Concrete) – “Ductal®”: pathway – “Flying Carpet”, Tomi Ungerer Museum – International Centre for Illustration, Strasbourg, France, 2007 [52]



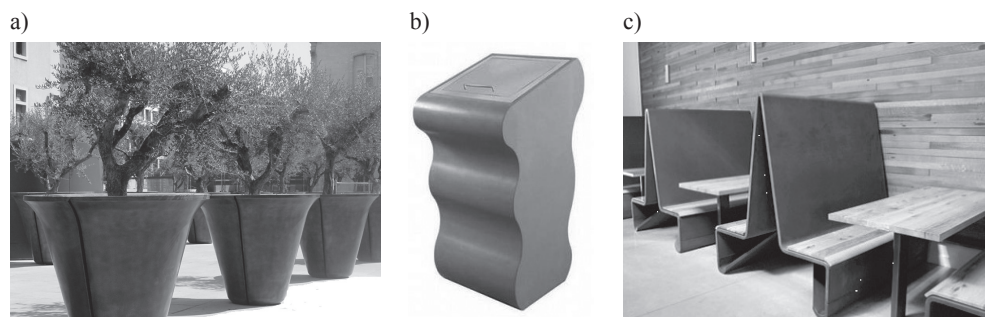

Fig. 15. Application of RPC (Reactive Powder Concrete) for “small architecture” elements: a – plant pots (“BSI/Ceram®”), Marseille, France, 2006 [49], b – litter-bin (“Ductal®”) [52], interior elements: c – benches (“Ductal®”) [30]

### 3. Bendable concrete

**Bendable concrete - ECC (Engineered Cementitious Composite)** belongs to the group of HPFRC (**H**igh **P**erformance **F**ibre Reinforced Cement Composite) because of the **very high plasticity** of the material. As a fibrous material, ECC does not destruct in a brittle manner. The first publications about this material appeared in the 90s of the twentieth century. ECC is the effect of the research conducted by Professor Victor C. Li from the University of Michigan in the USA [33, 34].

ECC is made from CEM I 42,5R Portland cement, siliceous fly ash, quartz sand, water, superplasticizer and fibrous reinforcement in the form of short polyvinyl alcohol (PVA) fibres. ECC does not contain coarse aggregate. The particle size (diameter) of composite components does not exceed 200  $\mu\text{m}$ : **1–100  $\mu\text{m}$**  (cement), **1–45  $\mu\text{m}$**  (fly ash), up to **200  $\mu\text{m}$**  (sand). The example of the proportion of the components (by mass) is as follows [42]: cement: fly ash: sand: water = 1:1.2:0.8:0.55. Superplasticizer is used in the amount of about 3% of the weight of the cement [42]. **PVA (Polyvinyl alcohol)** fibres with a length of 12 mm and diameter of 39  $\mu\text{m}$  (Tab. 1) are added in the amount of 2% by volume (26  $\text{kg}/\text{m}^3$ ) [7, 19, 20, 23, 42]. Siliceous fly ash should contain a minimum of 70%  $\text{SiO}_2 + \text{Al}_2\text{O}_3 + \text{Fe}_2\text{O}_3$ , a maximum of 5% sulphates calculated as  $\text{SO}_3$ , and the fineness should not exceed 34% (class F according to ASTM C618) [21]. A very high amount of fly ash, whose particles are smaller than cement grains, provides the uniformity of the cement matrix. The addition of fibres increases ductility (plasticity) of the composite.

New generation high performance fibrous composite ECC differs from plain **FRC (Fibre Reinforced Concrete)**, known and widely used for several decades, see [4, 8, 11, 45]) in behaviour during **tension**. ECC is a ductile material. Strain during tension in the case of ECC is 3–5% (in comparison to **0.01%** for plain concrete, **0.02–0.06%** for RPC) [16, 17, 19] (Fig. 17). ECC shows **hardening** after cracking during tension and therefore it belongs to the group of “strain-hardening” composites (according to Naaman’s classification from 2006 [27]); however, plain fibre reinforced concrete demonstrates softening after cracking, seen on the “stress-strain” curve (stress decreases after cracking) and belongs to the group of “strain-softening” composites (Ill. 16a).

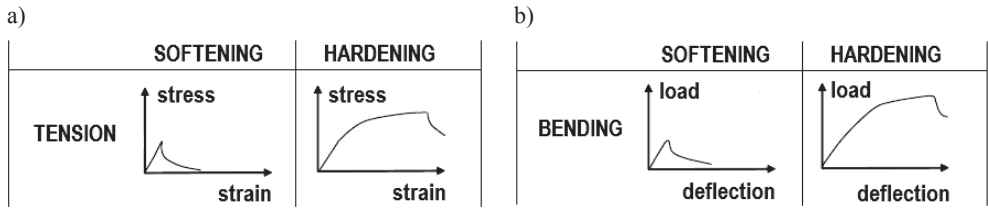

III. 16. Behaviour of composites during tension (a) and flexion (b): a – tension: softening after cracking (“strain-softening”), hardening after cracking (“strain-hardening”), b – flexion: softening after cracking (“deflection-softening”), hardening after cracking (“deflection-hardening”) [4, 7, 15, 20, 27]

In ECC subjected to tension, scattered microcracks with a width of less than 60 μm (about the size of half the diameter of a human hair) and ductile behaviour of material can be observed (see III. 17) [20, 42]. In the case of plain fibre reinforced concretes, the addition of fibres causes only the increase in concrete resistance to cracking (fibres take over tensile stresses and prevent the formation of cracks), but without visible changes in ductility. Contrarily, plain concrete destructs in a brittle manner (single cracks are formed, which may broaden very quickly and lead to the destruction of material). The presence of only micro-cracks, in the case of ECC, allows for **high durability** of this material because the transport of environmental media into the concrete takes place through the cracks with a width above 0.1 mm [7].

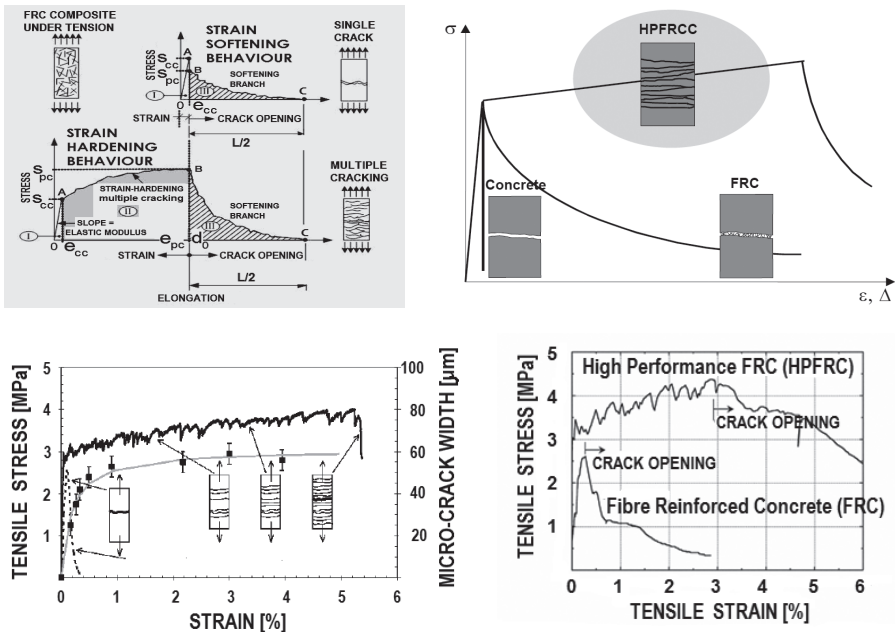

III. 17. Behaviour of ECC during tension – hardening after cracking (“strain-hardening”) seen on “stress-strain” diagram; the width of microcracks ( $s_{cc}/s_{pc}$  – first cracking /postcracking stress,  $e_{cc}/e_{pc}$  – first cracking /postcracking elongation) [16, 20, 21, 23, 27, 41, 44]

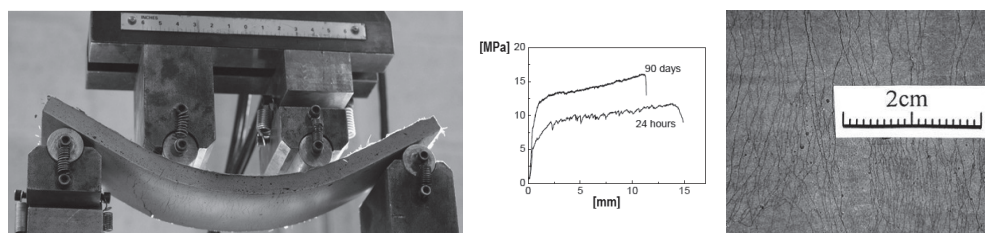

III. 18. Behaviour of ECC during flexion – hardening after cracking (“deflection-hardening”) seen on “stress-deflection” diagram and microcracks [20, 41]

Not only during tension, but also during bending, a large number of distributed microcracks and the lack of single, wide cracks are observed in ECC [20, 41] (III. 18).

ECC shows plastic behaviour during bending, reaching a 28-day flexural strength of about 15 MPa. Bendable concrete is characterized by **hardening** after cracking during bending. Thus, it belongs to the group of “deflection-hardening” composites (according to Naaman’s classification [27]) (see III. 16). ECC has also high shear strength, impact, fatigue and abrasion resistance [18, 22, 44].

In ECC, similar to RPC, the phenomenon of **self-healing (self-sealing)** of microcracks has been observed. The continuation of the hydration process whenever any micro-cracks appear (at the appropriate ambient humidity) can result from the high content of fly ash in ECC [23, 42]. The image of self-healing of microcracks is presented in III. 4b.

Advantageous strength and durability properties of ECC (bendable concrete) have determined its application as a **structural** and **architectural** material from which are constructed:

- structural elements to protect against hurricane winds, earthquakes and other natural disasters (by the absorption of the energy by the material), e.g., coupling beams (III. 19a),
- other structural elements: bridge deck link-slabs (III. 19b), elements of road pavements, floor panels, etc.,
- pipes (produced by extrusion method),

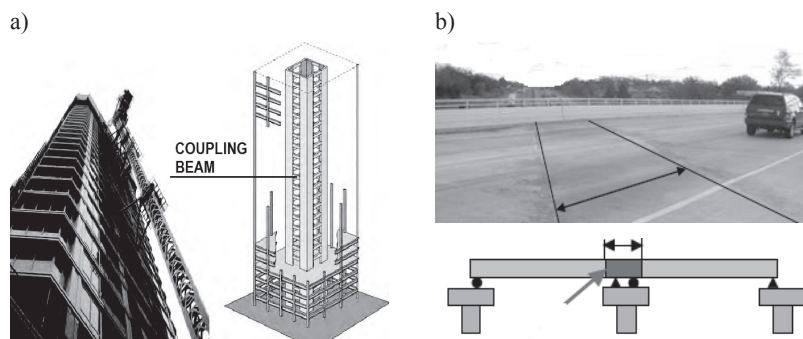

III. 19. Application of ECC: a – coupling beams, 41-storey building Nabeaura Yokohama Tower, Yokohama, Japan, 2010, b – bridge deck link-slab [18]

- architectural elements (prefabricated): cladding panels, façade sun-shades, elements of “small architecture” (e.g., benches, flower pots), etc.,
- protective coatings (as a corrosion protection), repair layers of e.g. bridge decks, strengthening of slopes with the application of spraying methods, etc. [17–20, 22].

#### 4. High performance cementitious composite with glass fibres

Fibre reinforced cement composite with glass fibres (**GRC**, **GFRC** – **Glass Fibre Reinforced Concrete**), which belongs to the group of High Performance Concretes (**HPC**, see Chapter 1), is fibre reinforced mortar with a compressive strength of 50–80 MPa from which external cladding panels are obtained (Ill. 20) [48, 53, 54]. The example of the composition of fibre reinforced mortar (for the implementation of elements by spraying method) is as follows [53]: 50kg of CEMI 42.5R Portland cement, 50 kg of sand 0/2 mm, 5 kg of polymer, 13.5 kg of water, 0.5 kg of superplasticizer and 5% (by volume) of AR (**Alkali Resistant**) glass fibres (with the properties given in Table 1). High-performance cement-polymer mortar, having a tensile strength of about 9 MPa, shear strength of 8–11 MPa and modulus of elasticity of 10–20 GPa, is also characterized by high durability resulting from the tight structure of the composite [53].

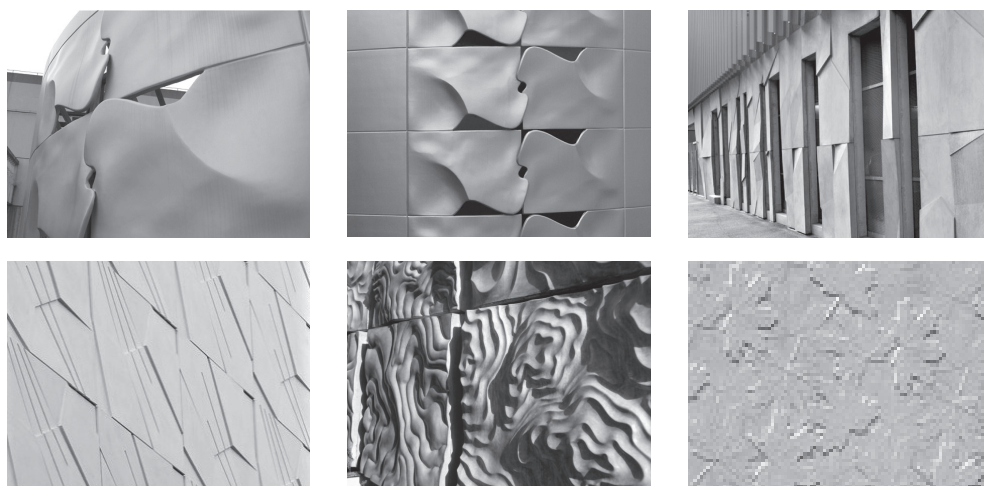

Ill. 20. Application of HPGRC (High Performance Glass Fibre Reinforced Concrete): cladding panels [48, 53, 54]

#### 5. Conclusions

New generation fibre reinforced cementitious composites are characterized in the paper. The possibility of the application of the latest advances in concrete technology for architects and constructors are presented. The high-performance cementitious fibrous composites of high



strength and/or plasticity (ductility) as well as durability and aesthetics allow for designing “new cubature and shapes”. By decreasing of the dimensions of construction elements (due to the high strength of the composites) and thus reducing the weight of the construction, it is possible to obtain slender and light construction elements (e.g. slabs of the thickness of 2 cm of RPC). Plastic composites (RPC, ECC) enable the formation of architectural elements of complicated shape with a smooth and non-cracked surface.

The article presents the possibility of the application of fibre reinforced composites as structural materials (to construct e.g. elements of footbridges, offshore and hydraulic structures, roof shells /RPC/, elements to protect against seismic actions /ECC/, road pavements) and as architectural materials /RPC, ECC, HPGFRC/ (to perform façade panels, elements with complicated shapes, e.g. elements of “small architecture”, etc.). The application of new generation high performance concretes fits well with the strategy of sustainable development because of the durability of composites [1, 3, 9] and also in the case of ECC due to the use of a waste material: siliceous fly ash.

Despite the still high price (the cost of 1 m<sup>3</sup> of RPC from which the world’s first building: the footbridge in Sherbrooke, Canada was made (Ill. 5) was around 1000US \$ in 1997 [1]), the current price is below half of this amount, depends on the country and has varied considerably [52]; the cost of ECC is related to the high price of polyvinyl alcohol (PVA) fibres: 20 Euro/kg [55]; the cost of 1 m<sup>2</sup> of HPGFRC cladding panels is about 80-100 Euros [48, 54]) new generation fibre cementitious composites are the “concretes of tomorrow” because they allow architects and designers to fulfill the eternal principles of design as contained in an ancient work of Vitruvius (first century BC) “The ten books on architecture” (“De Architectura” Libri Decem): “Architecture is to keep the three principles: durability (firmitas), utility (utilitas), beauty (venustas)”.

## References

- [1] Aïtcin P.-C., *Cements of yesterday and today. Concrete of tomorrow*, Cement and Concrete Research, 30, 2000, 1349-1359.
- [2] Aïtcin P.-C., *High-Performance Concrete*, E&FN Spon, 1998.
- [3] Aïtcin P.-C., *The art and science of durable high-performance concrete*, Conference “Concrete Days”, Szczyrk, 8–10.10.2002, 7-36 (in Polish).
- [4] Bentur A., Mindess S., *Fibre reinforced cementitious composites*, Taylor&Francis, 2007.
- [5] Blais P.Y., Couture M., *Precast, prestressed pedestrian bridge – world’s first reactive powder concrete structure*, PCI (Precast/Prestressed Concrete Institute) Journal, September–October 1999, 60-71.
- [6] Brandt A.M., *Cement based composites: materials, mechanical properties and performance*, Taylor&Francis, 2009.
- [7] Brandt A.M., *New generations of structural concrete*, Building Materials, 9, 2001, 182-188 (in Polish).
- [8] Chawla K.K., *Fibrous materials*, Cambridge University Press, 2005.
- [9] Czarnecki L., Kurdowski W., *Tendencies shaping the future of concrete*, Conference “Concrete Days”, Wisła, 9–11.10.2006, 47-64 (in Polish).

- [10] Glinicki M.A., *Concrete with structural reinforcement*, 25th Workshop for Structural Designers (“WPPK’2010”), Szczyrk, 10–13.03.2010, 279-308 (in Polish).
- [11] Hannant D.J., *Fibre-reinforced concrete*, [in:] J. Newman, B.S. Choo (Eds.), *Advanced Concrete Technology. Processes*, Elsevier Ltd., 2003, Chapter 6.
- [12] Henry K.A., Seibert P.J., *Manufacturing UHPC architectural products*, CPI (Concrete Plant International), Special Print: Concrete Technology, October 2011.
- [13] Kaszyńska M., *HPC: opportunities, properties, applications*, 17th Workshop for Structural Designers (“WPPK’2002”), Ustroń, 20–23.02.2002 (in Polish).
- [14] Kurdowski W., *Chemistry of cement and concrete*, Association of Cement Manufacturers / Polish Scientific Publisher, 2010 (in Polish).
- [15] Lappa E.S., *High Strength Fibre Reinforced Concrete. Static and fatigue behaviour in bending*, PhD Thesis, Delft University of Technology, Delft, The Netherlands, 28.06.2007.
- [16] Lepech M.D., Li V.C., *Long term durability performance of engineered cementitious composites*, International Journal for Restoration of Buildings and Monuments, Vol. 12, No. 2, 2006, 119-132.
- [17] Li V.C., *Advances in ECC research*, ACI (American Concrete Institute), SP 206-23, 2002, 373-400.
- [18] Li V.C., *Bendable composites. Ductile concrete for structures*, Structure, July 2006, 45-48.
- [19] Li V.C., *Durable overlay systems with Engineered Cementitious Composites (ECC)*, International Journal for Restoration of Buildings and Monuments, Vol. 9, No. 2, 2003, 1-20.
- [20] Li V.C., *Engineered Cementitious Composites (ECC) – material, structural and durability performance*, Concrete Construction Engineering Handbook, Taylor&Francis, 2008, Chapter 24.
- [21] Li V.C., *High Performance Fiber Reinforced Cementitious Composites as durable material for concrete structure repair*, International Journal for Restoration of Buildings and Monuments, Vol. 10, No. 2, 2004, 163-180.
- [22] Li V.C., Kanda T., *Engineered Cementitious Composites for structural applications*, Journal of Materials in Civil Engineering, Vol. 10, No. 2, 1998, 66-69.
- [23] Li V.C., Yang E., *Self healing in concrete materials*, van der Zwaag S., Self Healing Materials. An Alternative Approach to 20 Centuries of Materials Science, Springer, 2007, 161-193.
- [24] Łukasik U., J., Acker P., Vernet Ch., Behloul M., *Ductal®: ultrahigh-performance concrete with ductility*, Conference “Concrete Days”, Wisła, 11–13.10.2004, 111-124 (in Polish).
- [25] Maeder U., Lallemand-Gamboa I., Chaignon J., Lombard J.P., *CERACEM – a new high performance concrete: characterization and applications*, International Symposium “Ultra High Performance Concrete” (“UHPC”), Kassel, Germany, 13–15.09.2004, 67-76.
- [26] Mindess S., *High performance concrete: recent developments in material design*, International Seminar “Design and Application of High Performance Cement Based Materials”, IPPT PAN, Warszawa, 16–18.10.2003.
- [27] Naaman A.E., *High performance fiber reinforced cement composites: classification and applications*, International Workshop “Cement Based Materials and Civil Infrastructure” (“CBM-CI”), Karachi, Pakistan, 10–11.12.2007, 389-401.

- [28] Neville A.M., *Properties of concrete*, Association of Cement Manufacturers, Cracow, 2012 (in Polish).
- [29] Nocuń-Wczelik W., *Application of silica fume in concrete technology*, Ceramic Materials, 2, 2007, 68-71 (in Polish).
- [30] Perry V.H., Seibert P.J., *Manufacturing UHPC artisan products*, CPI (Concrete Plant International), Special Print: Concrete Technology, August 2011.
- [31] Perry V.H., Seibert P.J., *Manufacturing Ultra-High Performance Concrete structural products*, CPI (Concrete Plant International), Special Print: Concrete Technology, June 2011.
- [32] Perry V.H., Seibert P.J., *Working with Ductal Ultra-High Performance Concrete*, CPI (Concrete Plant International), Special Print: Concrete Technology, February 2011.
- [33] Richard P., Cheyrezy M., *Composition of reactive powder concrete*, Cement and Concrete Research, Vol. 25, No. 7, 1995, 1501-1511.
- [34] Richard P., Cheyrezy M., *Reactive Powder Concrete with high ductility and 200–800 MPa compressive strength*, ACI (American Concrete Institute), SP 144-24, 1994, 507-518.
- [35] Russell H.G., Graybeal B.A., *Ultra-High Performance Concrete: a state-of-the-art Report for the Bridge Community*, Report No. FHWA-HRT-13-060, Federal Highway Administration, McLean (VA), USA, June 2013.
- [36] Shah S.P., *High Performance Concrete: strength vs. ductility and durability*, International Symposium on Non-Traditional Cement & Concrete, Brno, Czech Republic, 11–13 June 2002, 347-358.
- [37] Sorelli L., Constantinides G., Ulm F.J., Toutlemonde F., *The nano-mechanical signature of Ultra High Performance Concrete by statistical nanoindentation techniques*, Cement and Concrete Research, 38, 2008, 1447-1456.
- [38] Śliwiński J., Zdeb T. *Reactive Powder Concrete (RPC) as ultra high strength cement-based composite*, New Generation Cement Concretes (NGCC) – Ideas, Design, Technology and Applications, LLP-ERASMUS-IP 9203-0574, Kraków 2010, 108-122.
- [39] Toutlemonde F., Resplendino J. (editors), *Designing and building with UHPFRC: state-of-the-art and development*, John Wiley&Sons, 2011.
- [40] Vicenzino E., Culham G., Perry V.H., Zakariasen D., Chow T.S., *First use of UHPFRC in thin precast concrete roof shell for Canadian LRT Station*, PCI (Precast/Prestressed Concrete Institute) Journal, Vol. 50, September-October 2005, 50-67.
- [41] Wang S., Li V.C., *Polyvinyl alcohol fiber reinforced engineered cementitious composites: material design and performances*, International RILEM Workshop “High Performance Fiber Reinforced Cementitious Composites (HPFRCC) in Structural Applications”, Honolulu, Hawaje, 23–26.05.2005, 65-73.
- [42] Yang Y., Lepech M.D., Yang E.-H., Li V.C., *Autogenous healing of engineered cementitious composites under wet-dry cycle*, Cement and Concrete Research, 39, 2009, 382-390.
- [43] Zdeb T., Śliwiński J., *The influence of steel fibre content and curing conditions on mechanical properties and deformability of Reactive Powder Concrete in bending*, 9th International Symposium “Brittle Matrix Composites” (BMC 9), Warszawa, 25–28 October 2009, 33-42.
- [44] van Zijl G.P.A.G., Wittman F.H., *Durability of strain-hardening fibre-reinforced cement-based composites (SHCC)*, RILEM State-of-the-Art Reports, Vol. 4, Springer, 2011.

- [45] Zych T., *Contemporary fibre reinforced concrete – possibility of forming of structural elements and architectural forms*, Czasopismo Techniczne (Technical Transactions), 8-A, Issue 18, 2010, 371-386 (in Polish).
- [46] PN-EN 206-1:2003 Concrete–Part 1: Specification, properties, production and conformity (in Polish).
- [47] <http://f2fcontinuum.wordpress.com/notes-on-materials-and-techniques>; access: 15.09.2013.
- [48] <http://www.architecturalmaterials.com/gfrc-high-performance-cement-cladding>; access: 15.09.2013.
- [49] <http://www.bsieiffage.com>; access: 15.09.2013.
- [50] <http://www.dezeen.com/2007/12/03/thiais-bus-centre-by-ecdm-architects>; access: 15.09.2013.
- [51] <http://www.designboom.com/architecture/mucem-by-rudy-riccioti-sports-a-delicate-concrete-filigree>; access: 15.09.2013.
- [52] <http://www.ductal-lafarge.com>; access: 15.09.2013.
- [53] <http://www.greenvironments.com.au>; access: 15.09.2013.
- [54] <http://www.grcuk.com>; access: 15.09.2013.
- [55] <http://www.kuraray.eu>; access: 15.09.2013.
- [56] <http://www.nxtbook.fr/newpress/Sika/ceracem>; access: 15.09.2013.
- [57] [http://www.theconcreteportal.com/reac\\_pow.html](http://www.theconcreteportal.com/reac_pow.html); access: 15.09.2013.

PAWEŁ ŻWIREK\*

## SELECTED ISSUES OF STRUCTURE FORMING OF THE CONTEMPORARY SINGLE AND MULTI-CURVED ROOFS

### WYBRANE ZAGADNIENIA KSZTAŁTOWANIA KONSTRUKCJI WSPÓŁCZESNYCH DACHÓW JEDNO- I WIELOKRZYWIZNOWYCH

#### Abstract

In modern architecture, the roof function is not only to protect buildings against environmental influences. Designers often use single or multi-curved roofs. One of the issues to be considered at the structural design stage is selection of the support structure technology, thanks to which it will be possible to obtain a curved roof with a smooth surface. In case of objects such as airport terminals (eg., in Wrocław, Łódź, Rzeszów-Jasionka), sports and entertainment halls, conference centers (such as presently constructed in Kraków) and theme parks, mostly self-supporting metal panels are used (usually aluminum, about the length of one element up to tens of meters). The paper will present selected issues of forming the supporting structure of the multi-curved roofs made of self-supporting metal panels.

*Keywords: roof structure, metal cladding, multi-curved roof*

#### Streszczenie

We współczesnej architekturze dach przestał pełnić funkcję czysto techniczną sprowadzającą się jedynie do ochrony wnętrza budowli przed wpływami środowiskowymi. Projektanci obiektów często stosują dachy o postaci powierzchni jedno- lub wielokrzywiznowej. Jedną z kwestii, które należy rozważyć na etapie sporządzania projektu konstrukcji nośnej dachu, są rozwiązania techniczne, dzięki którym możliwe będzie uzyskanie gładkiej powierzchni zakrzywionej połączy dachowej. W przypadku takich obiektów jak terminale lotnicze (np. we Wrocławiu, Łodzi, Rzeszowie-Jasionce), hale widowiskowo-sportowe, centra konferencyjne (jak np. budowane obecnie w Krakowie), parki rozrywki stosowane są przeważnie samonośne panele metalowe – na ogół aluminiowe – o długości jednego elementu dochodzącej do kilkudziesięciu metrów. W artykule zostaną przedstawione wybrane zagadnienia kształtowania konstrukcji nośnej dachów wielokrzywiznowych z pokryciem wykonywanym z samonośnych paneli metalowych.

*Słowa kluczowe: konstrukcja dachu, pokrycie metalowe, dach wielokrzywiznowy*

\* Ph.D. Eng. Paweł Żwirek, Faculty of Civil Engineering, Cracow University of Technology.



## 1. Introduction

Roofs of buildings currently under construction, in addition to safe handling of loads acting on them and for protection of the interior of buildings against environmental influences, often become the “fifth façade” which confers a unique character of the building. A very dynamic development of CAD software supporting design work, allows creating detailed design documentation for objects with complex geometries. Roofs of modern airport terminals, sports and entertainment halls, stadiums and conference facilities often have roofs with a single- or multi-curved surface (see Ill. 1). The aesthetic appearance of the metal cover

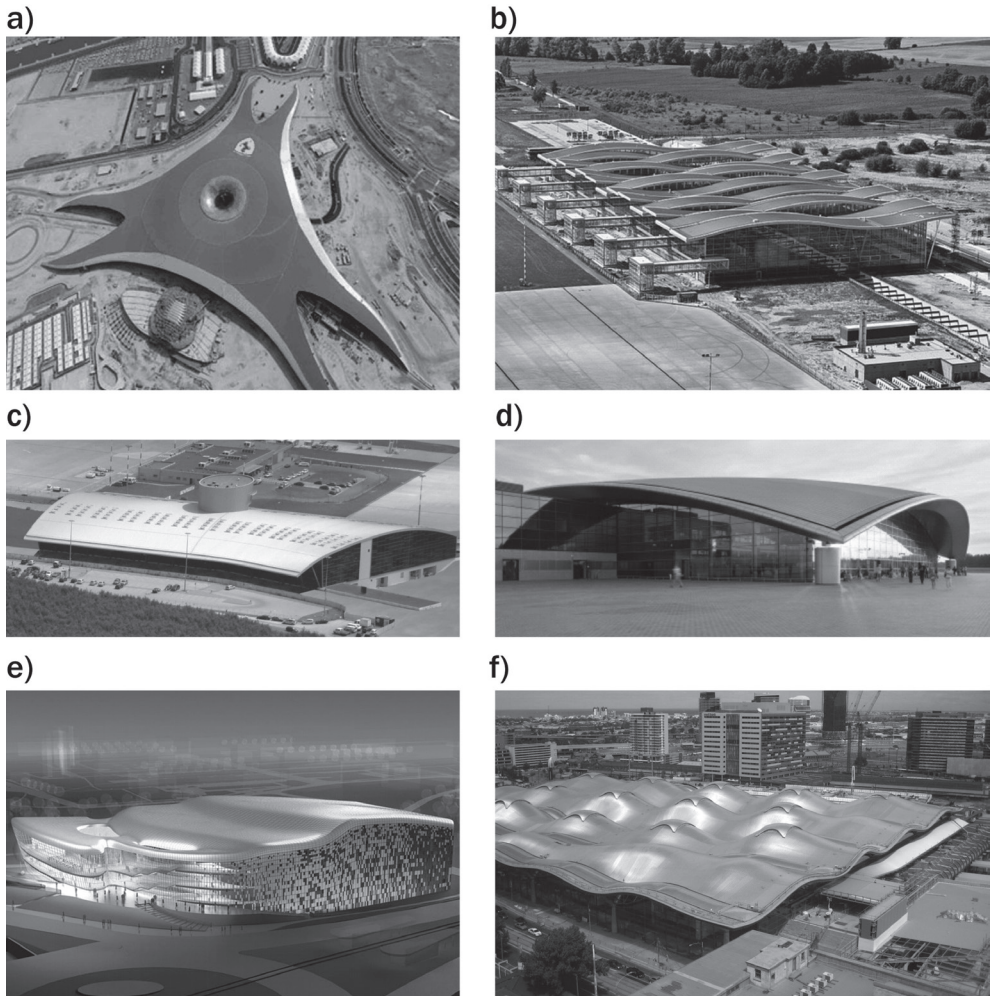

Ill. 1. Examples of roofs covered with self-supporting metal panels: a) Ferrari World Abu Dhabi [14], b) airport terminal in Wrocław [18] c) airport terminal in Łódź [16], d) airport terminal in Rzeszów Jasionka [9], e) Convention Center in Kraków now under construction [11], f) Southern Cross Station Melbourne, Australia [17]

and the possibility of forming complex shapes while maintaining the integrity and durability, enable their wide use for these objects. Among the currently used types of metal roofing materials the most technologically advanced are self-supporting metal panels with a standing seam and carried out in accordance with the standards [3, 4, 6, 7]. This article will present selected issues of forming the supporting structure of the multi-curved roofs made of self-supporting metal panels.

Proper formation of the roof support structure, usually steel with complex geometry, requires knowledge of roof cladding systems with self-supporting metal panels. Currently there are a number of similar roofing systems of self-supporting metal panels on the market (e.g., [10, 12, 13]). The system consists mainly of metal panels produced on site from metal sheets (in coils) in a range of up to several tens of meters. For objects as shown in Ill. 1c and 1d, roof panels have a length equal to the distance between the drainage troughs located at the eaves on both sides of the roof. The panels are supported on brackets spot called clips (see Ill. 2).

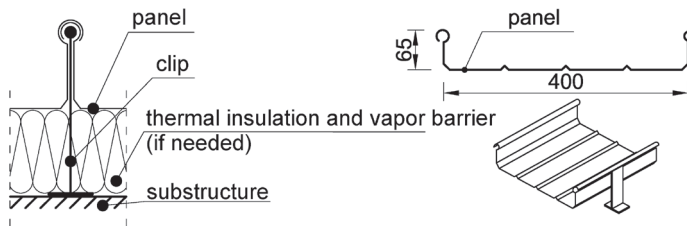

Ill. 2. Cover of the roof with self-supporting metal panels: components and sample shape of panel

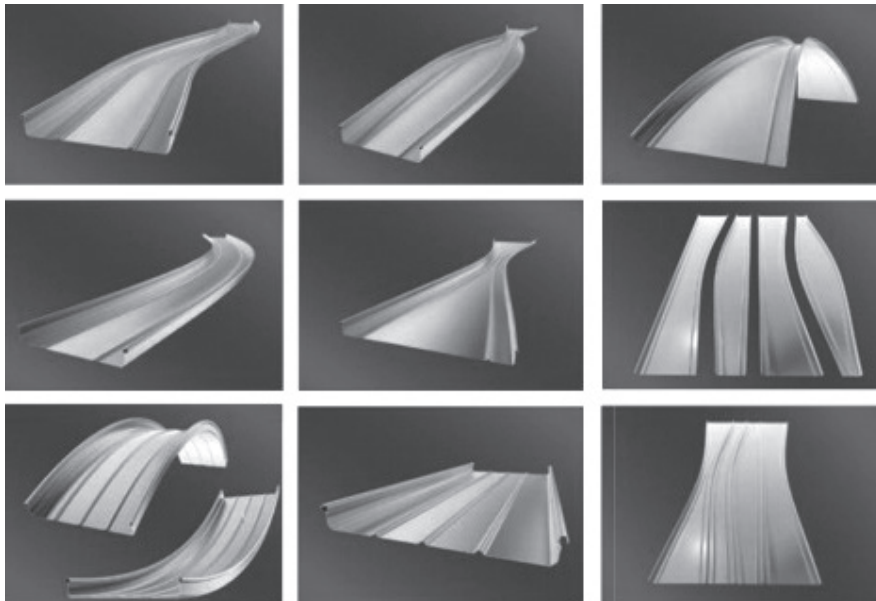

Ill. 3. Sample shapes of roof panels [10]



Description of the systems, methods of manufacturing and assembly of self-supporting roofing metal panels can be found in the paper [19]. Shapes of panels possible to produce (see Ill. 3) allow making airtight and aesthetic roofings even with very complex geometry.

## 2. Structural issues

Roofing panels only reproduce the shape that results from the location in the space grid points to which the clips are attached. Construction of clips does not allow for a smooth change of their length, therefore for proper shaping of the structure supporting the clips is of utmost importance to achieve the designed shape of the roof. The method for forming the roof structure is affected by: roof barrier layer system, the orientation of the panels in reference to the elements supporting the clips, roof shape. For single-curved roofs without thermal insulation, the simplest solution is to fix the design clips directly to the roof purlins arranged perpendicularly to the roof panels. During the design phase of construction it is important to match the spacing of purlins to the required spacing of clips. Allowable spacing of clips depends on the loads on the roof panels and the type of adopted panel (panel shape, type and thickness of the material). In the selection of clips' spacing, specialists in engineering departments of vendors and the information contained in such publications as [1, 2] might be helpful. Roof purlins should be designed so that their top flanges are aligned parallel to the tangent of the roof slope at rest point of the roof slope on the clip. For the present design solution roof beams can be both curved and piecewise linear (Ill. 4). The use of curved beams, purlins and panels of suitable shape makes it relatively easy to achieve a multi-curved roof.

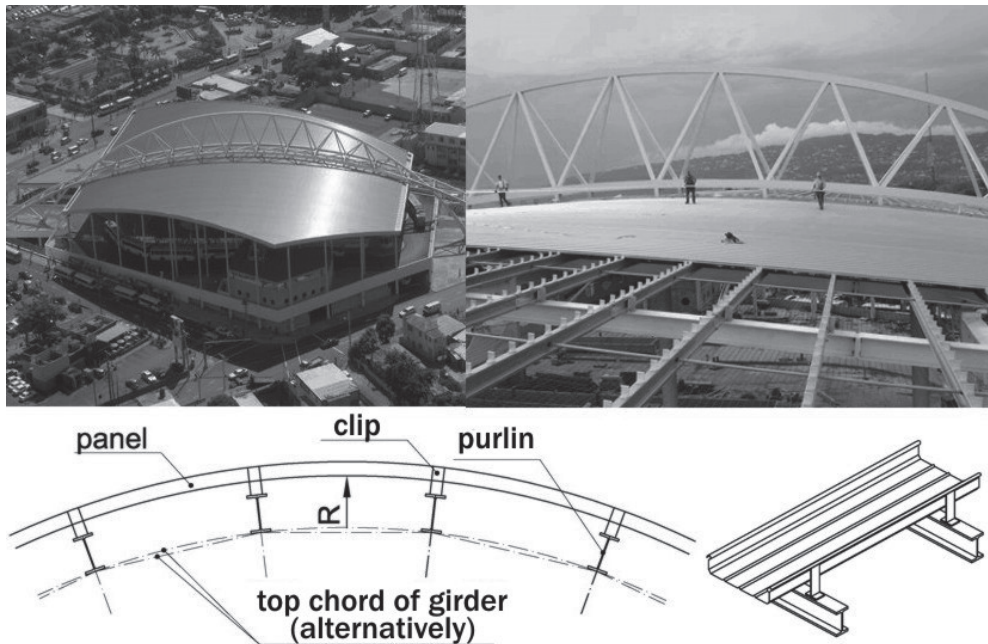

Ill. 4. Construction of the non-insulated single-curved roof

Non-insulated metal panel roofs may be used as so-called false roofs, which are used for higher visual aesthetics instead of the proper, sealed and insulated flat roof, along with the devices installed on the roof such as intakes, exhausts and air conditioning systems. These solutions were used in the currently constructed congress centre in Krakow.

If for economic or construction reasons it is required to use purlins with spacing greater than the allowable spacing of clips supporting the panels, trapezoidal sheets are used additionally. Trapezoidal sheets are also used in situations where directly under the roofing panels insulation is to be laid. In case of the roof shape as e.g., of the airport terminal in Wroclaw (see III. 1b, III. 5a), the roof structure consists of a suitably profiled girders and purlins. The purlins are covered with arch bent trapezoidal sheets. The use of arch bent trapezoidal sheets is generally economically feasible only for small differences due to the bending radius and the length of the number of types of sheets, which must be delivered to the construction site.

a)

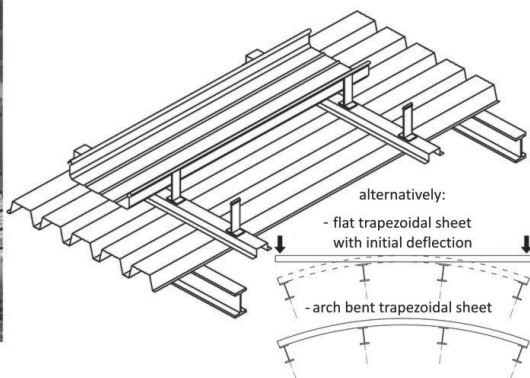

b)

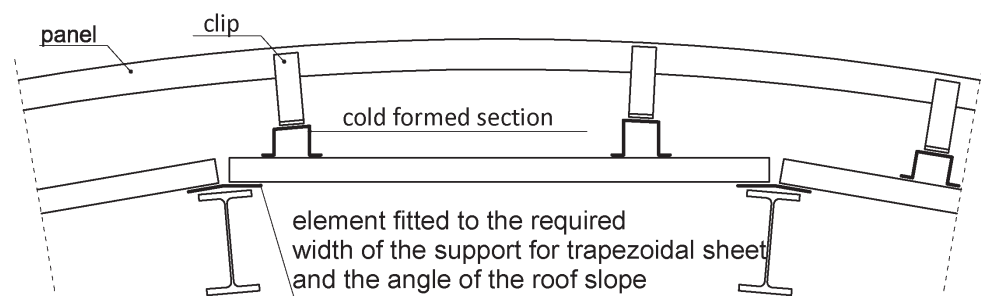

III. 5. Structure of single-curved insulated roof using: a) curved folded sheets, b) flat sheets

Due to the relatively small selection of arch bent trapezoidal profiles (compared to flat ones), flat trapezoidal sheets are used instead. Flat trapezoidal sheets are bent during assembly to the designed curvature of the roof (see III. 5a) set by location of e.g., roof purlins. The effect of initial deflection on the strength of the trapezoidal sheet can be significant and should be

taken into account when computing the static strength [5]. One should remember about the parallel to the tangent to the designed curve of arrangement of flanges of roof purlins. Roof panels are placed parallel to the folds of the sheet. The width of the roof panels is usually not a multiple of the width of the sheet folds, which prevents the assembly of clips directly to the trapezoidal sheet, as it can be in the case of the perpendicular arrangement of the panels and folds of the trapezoidal sheet (see Ill. 6). It is therefore necessary to introduce additional substructure. In the case of arch bent trapezoidal sheets or trapezoidal flat sheets with initial deflection, all the elements of the substructure may have the same shape. It is also possible to obtain a single-curved roof shape as in fig. 1b using a flat sheet without initial deflection. In such a situation purlins allowing for the proper support of the trapezoidal sheet should be designed as well as the substructure for clips of cold formed sections of suitable cross-sectional shape (see Ill. 5b). In the static strength calculation, one should consider the linear nature of the load of trapezoidal sheets by substructure supporting clips.

For single-curved roofs with insulation, one of the simplest design solutions is the use of the roof structure without purlins (see Ill. 6). The trapezoidal sheet is laid directly on the top chords of properly profiled roof girders. Roof panels run perpendicularly to the fold of the trapezoidal sheet. Axial spacing of clips is a multiple of axial spacing of the sheet folds. In the static strength calculations of the trapezoidal sheet, one should consider the nature of the load transferred from the roof panels to individual sheet folds. To avoid overloading a single fold sheet, clips of subsequent panels are moved along the standing seam of a sheet fold.

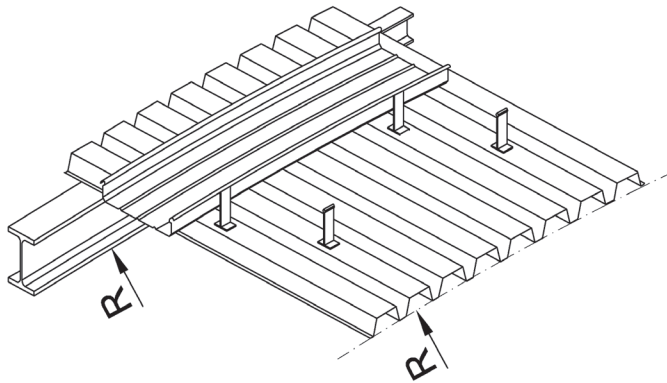

Ill. 6. Single-curved roof without purlins with trapezoidal sheet

For the roof as shown in Ill. 1d using only perpendicular or parallel position of panels regarding sheet folds is virtually impossible. Because of the variation in radius of curvature, the use of arch bent trapezoidal sheets can be economically unjustified. In this case, it is possible to use trapezoidal flat sheets. Individual folds of originally flat trapezoidal sheets are pre-bent, twisted or bent laterally or transversely deformed as a result of deliberate changes in the width of the folds [8]. Trapezoidal sheets are attached to a specifically shaped steel structure. Roof clips are attached to the substructure extending obliquely with respect to roof panels and sheet folds (see Ill. 7).

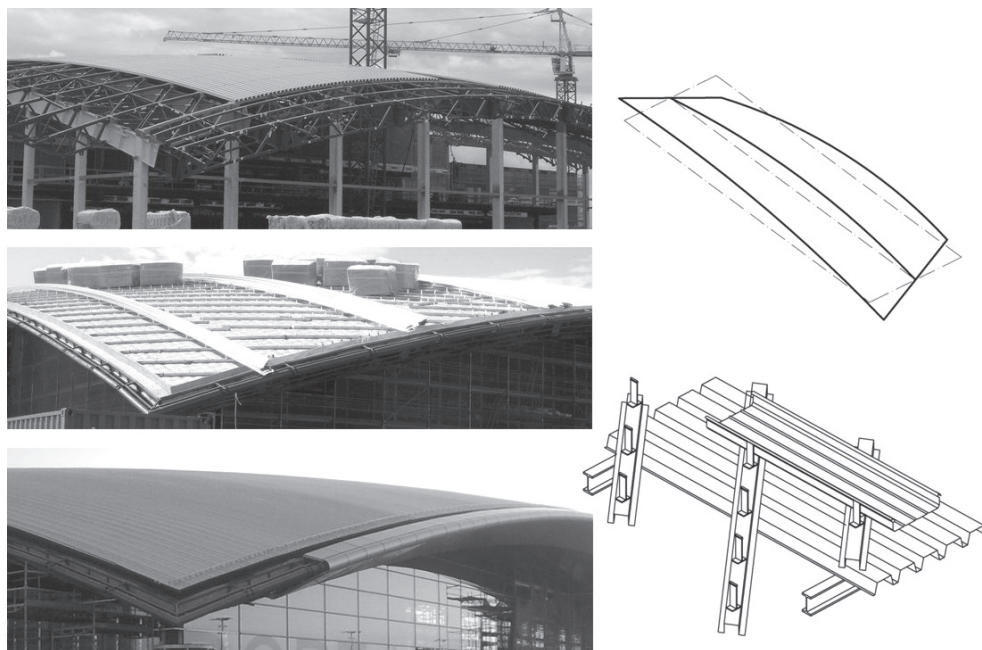

III. 7. The structure of two-curve roof [15]

Another of the most technologically advanced ways to achieve a roofing of complex shape, is to use special clips mounted on the rotating base installed on a curved section bar of the circular cross section (see Ill. 8). It is both possible to move and turn the clip relatively to the base of the profile. After determining the correct position, the base is stabilized by using mechanical fasteners. Thanks to this, the main support structure can be designed from simple straight elements, which only approximate the curvature of the roof. This solution makes full use of opportunities to develop roofings from panels of shapes as in Ill. 3. Installing the system requires constant surveying supervision.

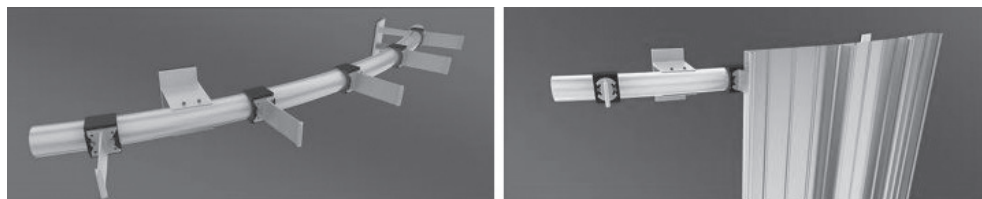

III. 8. Bemo-Dome system structure[10]

### 3. Conclusions

Possibilities of modern software supporting design work and technological advancement of carrying out roofing systems from self-supporting metal panels, allow

for making tight and aesthetic roofing even in the most complex geometry of the roof slope. At the stage of making technical and economic analyses in the selection of design solutions of roof systems, one must consider the requirements of self-supporting metal panels. Proper configuration of the supporting structure allows the realization of aesthetic and cheap solutions (Ill. 4).

## References

- [1] Allgemeine Bauaufsichtliche Zulassung Z-14.1-181 Kalzip-Aluminium-Stehfalzprofil-Dach.
- [2] Allgemeine Bauaufsichtliche Zulassung Z-14.1-419 Aluminium-Stehfalzprofil-Dachelemente Falz-Ripp.
- [3] PN-EN 14782:2008 Samonośne blachy metalowe do pokryć dachowych, okładzin zewnętrznych i wewnętrznych. Charakterystyka wyrobu i wymagania.
- [4] PN-EN 508-1:2010 Wyroby do pokryć dachowych z metalu. Charakterystyka wyrobów samonośnych z blachy stalowej, aluminiowej lub ze stali odpornej na korozję. Część 1: Stal.
- [5] Pięciorak E., Żwirek P., *Wpływ wygięcia wstępnego na nośność blachy faldowej, Izolacje: budownictwo, przemysł, ekologia*, 11-12/2011.
- [6] PN-EN 508-2:2010 Wyroby do pokryć dachowych z metalu. Charakterystyka wyrobów samonośnych z blachy stalowej, aluminiowej lub ze stali odpornej na korozję. Część 2: Aluminium.
- [7] PN-EN 508-3:2010 Wyroby do pokryć dachowych z metalu. Charakterystyka wyrobów samonośnych z blachy stalowej, aluminiowej lub ze stali odpornej na korozję. Część 3: Stal odporna na korozję.
- [8] Reichhart A., *Analiza powłok z blach faldowych*, Nowoczesne Hale, 1/2011.
- [9] [www.apa.krakow.pl](http://www.apa.krakow.pl); access: 15.09.2013.
- [10] [www.bemo.com](http://www.bemo.com); access: 15.09.2013.
- [11] [www.iea.com.pl](http://www.iea.com.pl); access: 15.09.2013.
- [12] [www.interfalz.com](http://www.interfalz.com); access: 15.09.2013.
- [13] [www.kalzip.com.pl](http://www.kalzip.com.pl); access: 15.09.2013.
- [14] [www.meconstruct.be](http://www.meconstruct.be); access: 15.09.2013.
- [15] [www.me.com.pl](http://www.me.com.pl); access: 15.09.2013.
- [16] [www.rotwl.pl](http://www.rotwl.pl); access: 15.09.2013.
- [17] [www.trifixx.com.au](http://www.trifixx.com.au); access: 15.09.2013.
- [18] [www.wroclaw.naszemiasto.pl](http://www.wroclaw.naszemiasto.pl); access: 15.09.2013.
- [19] Żwirek P., *Wybrane zagadnienia projektowania dachów z pokryciem metalowym*, Czasopismo Techniczne, 2-A/1/2011.

BUILDING PHYSICS

---

FIZYKA BUDOWLI





ALEKSANDER BYRDY\*

## A MOISTURE TRANSFER IN EXTERNAL WALLS WITH NATURAL STONE CLADDING GLUED DIRECTLY TO THERMAL INSULATION LAYER

### TRANSPORT WILGOCI PRZEZ ŚCIANY ZEWNĘTRZNE Z OKŁADZINĄ KAMIENNĄ KLEJONĄ BEZPOŚREDNIO DO WARSTW IZOLACJI TERMICZNEJ

#### Abstract

Currently the most common stone cladding facades are made of 3 to 4 cm thick panels fixed with steel anchors. A new approach of gluing 2 cm thick stone boards directly to the thermal insulation layer made of EPS polystyrene or mineral wool insulation is currently investigated. The aim of the article is to present natural stone cladding hygrothermal properties obtained from laboratory research. Also analysis results of moisture transfer through wall thickness are provided for the walls finished with a natural stone cladding glued directly to the thermal insulation layer.

*Keywords: natural stone claddings, moisture transfer*

#### Streszczenie

Współcześnie najbardziej popularną technologią wykonywania elewacyjnych okładzin kamiennych są okładziny wentylowane z płyt o grubości od 3 do 4 cm, mocowane na kotwicach stalowych. Nowym, obecnie wprowadzanym do stosowania rozwiązaniem jest klejenie dwucentymetrowej grubości płyt kamiennych bezpośrednio do warstwy izolacji termicznej ze styropianu EPS lub z wełny mineralnej. Celem artykułu jest przedstawienie parametrów ciepłno-wilgotnościowych okładzin z kamienia naturalnego uzyskanych z badań laboratoryjnych, a także analiza przepływu wilgoci przez ścianę z zewnętrzną okładziną kamienną klejoną bezpośrednio do warstwy izolacji termicznej.

*Słowa kluczowe: okładziny z kamienia naturalnego, transport wilgoci*

\* D.Sc. Aleksander Byrdy, Institute of Building Materials and Structures, Faculty of Civil Engineering, Cracow University of Technology.

## 1. Introduction

The function of stone, applied in historical buildings, has been currently and significantly altered in modern civil engineering. Solid and structural (beam and trusts) elements have been replaced by thin-layer stone claddings laid on reinforced concrete walls, brick walls and other structural elements made of various building materials. The changes of stone function are caused mostly by: economic, structural strength and workmanship factors. Modern stone claddings are commonly used at representative building facades. These buildings are often designed as tall structures located in large urban agglomerations. Typical stone facings are connected to the structure with both stainless steel and aluminum anchoring systems.

A new solution of gluing thin-layer stone claddings directly to the structure thermal insulation layer is being introduced. In the first stage, the installation method is similar to making thermal insulation together with thin-layer plasters in the ETICS system. Arrangement of layers in the component with stone cladding glued directly to the thermal insulation of the wall is shown in Ill. 1.

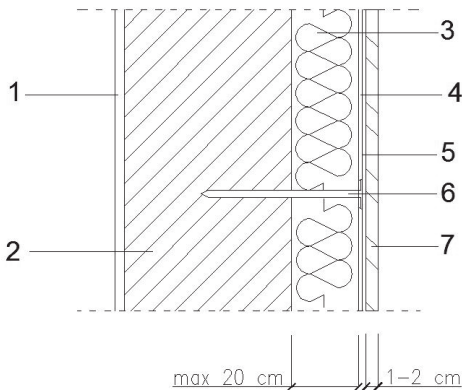

Ill. 1. Section of external walls with a natural stone cladding glued directly to the thermal insulation layer: 1 – internal plaster, 2 – bearing wall, 3 – thermal insulation layer, 4 – adhesive mortar, 5 – reinforcing fabric, 6 – PVC fastener, 7 – stone cladding

The stone facing is glued directly to the thermal insulation in several steps. In the first step, the thermal insulation layer made of polystyrene, XPS or mineral wool up to 20 cm thick is attached on the gluing mortar to the structural base. In the second step the thermal insulation layer is covered with a reinforcing fiberglass mesh glued with white cement mortar. Next, to improve thermal insulation adherence to the structural base, mechanical (PVC) fasteners are installed. On such a prepared substrate, thin-layer stone boards of a surface density of up to 40 kg/m<sup>2</sup> are laid [2]. At the final stage, once the gluing mortar dries, the point board joints are made. The technology of fixing the claddings directly to thermal insulation is much cheaper than traditional technology, but due to the lack of the layer of ventilated air, there can be problems with water vapour diffusion through the building component.

## 2. Stone cladding water vapor diffusion resistance

### 2.1. Natural stones vapor diffusion resistance

Thermally insulated external wall layers should be characterized by low water vapor diffusion resistance. Depending on the quality of the stone type, the stone claddings applied as an external layer exhibit different diffusion resistance coefficients. Vapor diffusion resistance coefficient values for various stone type qualities are summarized in Table 1.

Table 1

**Water vapour diffusion factors for different stone types according to [3]**

Stone sort quality	Vapor diffusion resistance factor $\mu$	
	Dry	Wet
Natural stone-crystalline rock	10 000	10 000
Natural stone-sedimentary rock	250	200
Natural stone-light sedimentary rock	30	20
Natural porous stone (e.g. lava)	20	15
Basalt	10 000	10 000
Bastrad granite-genesis	10 000	10 000
Granite	10 000	10 000
Marble	10 000	10 000
Limestone extremely soft	30	20
Limestone soft	40	25
Limestone semi-hard	50	40
Limestone hard	200	150
Limestone extremely hard	250	200
Sandstone	40	300
Natural pumice stone	8	6

Natural stone physical parameters strongly depend on: chemical constitution and composition, structure and density. The vapor diffusion resistance factor value for the particular stone type qualities should be evaluated as based on research made on samples taken from particulars beds. Vapor diffusion resistance factor values for two of the most popular polish sandstones evaluated from laboratory research are shown in Table 2.

### 2.2. Moisture transfer throughout the walls with natural stone cladding

Granite, hard limestone, semi-hard limestone and sandstone reveal the best aesthetic and functional qualities. However, granite stone claddings show a high water vapor diffusion resistance coefficient value. Better water vapor diffusion resistance factor values are displayed by limestone and sandstone. Although sandstone cladding displays a relatively low vapor diffusion resistance value due to low strength parameters, sandstone claddings should be designed at least 2 cm thick.

**Sandstone vapor diffusion resistance factor values evaluated from laboratory research**

Stone type quality	Vapor diffusion resistance factor $\mu$	
	Dry	Wet
Sandstone "Skala"	20,3	18,5
Sandstone "Czaple"	22,7	19,5

In polish climatic conditions, moisture interstitial condensation in the walls designed with stone claddings glued directly to the thermal insulation layers is observed only during the winter season. An example of moisture pressure distribution based on the "Fick" law and worked out for the wall made of an inner concrete bearing layer and externally insulated with polystyrene is depicted on Ill. 2. The seasonal water vapor condensation balance at a wall for the typical climatic conditions in Cracow Poland (an average value for a 30 year period) for a concrete reinforced wall insulated with polystyrene is depicted in Ill. 3.

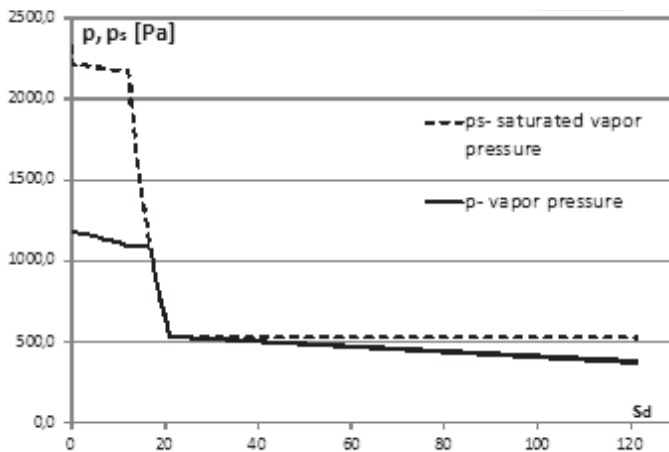

Ill. 2. Moisture pressure distribution scaled in terms of vapor diffusion thickness for the wall made of reinforced concrete insulated with polystyrene and granite stone claddings glued directly to the insulation layer (see also Table 3)

**Water vapor transfer throughout the bulkhead is significantly impacted by stone cladding humidity.** Wet stone, depending on its kind, may indicate a different vapor diffusion resistance than dry stone. Stone cladding humidity may be caused not only by interstitial moisture condensation but also by rainfall. Stone cladding is highly prone to soak and once it becomes humid, it may impact on the humidity of the wall insulation layers. In order to analyze the above described phenomena, calculations of moisture transfer through the wall with stone cladding glued directly to the thermo-insulation layer have been made utilizing

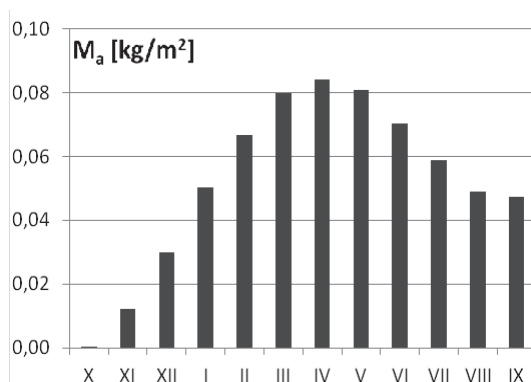

III. 3. Moisture condensation annual balance for the wall made of reinforced concrete insulated with polystyrene and granite stone claddings glued directly to the insulation layer

WUFI software. For the purpose of analysis, the multi-layer walls insulated by polystyrene foam EPS and mineral wool combined with stone cladding made of granite, limestone and sandstone have been used. The northern wall of a residential building (located in Cracow Poland) subjected to the climatic changes for a period of two years, beginning from September to September two years later, has been analyzed. The results demonstrated by the analysis of the humidity changes of insulation layers, also taking into account the process of technological dry up, are shown on the pictures 4, 5 and 6.

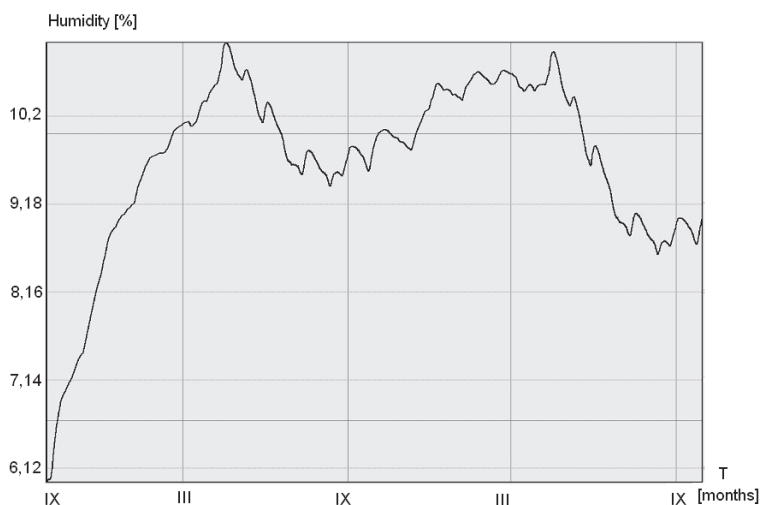

III. 4. Chart of the polystyrene EPS humidity changes in the wall of a reinforced concrete structure and granite cladding

The scope of the research covers the seasonal moisture balance analysis for the walls insulated with polystyrene EPS or mineral wool and stone cladding and for the wall heat



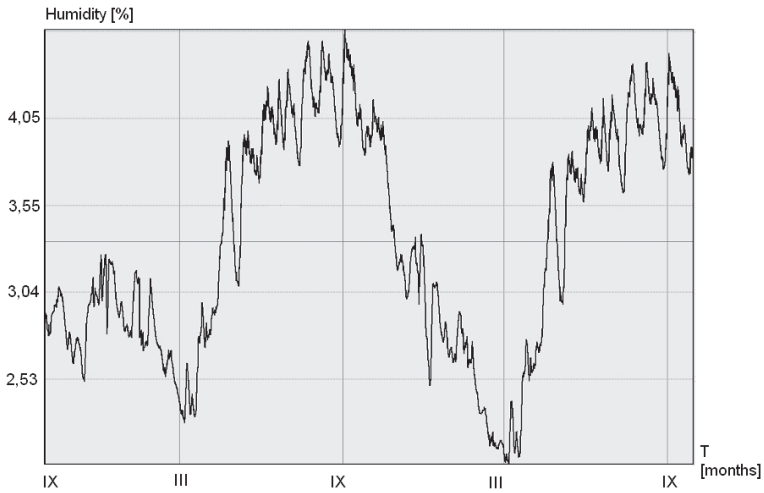

III. 5. Mineral wool humidity changes in the wall made of reinforced concrete structure with sandstone cladding

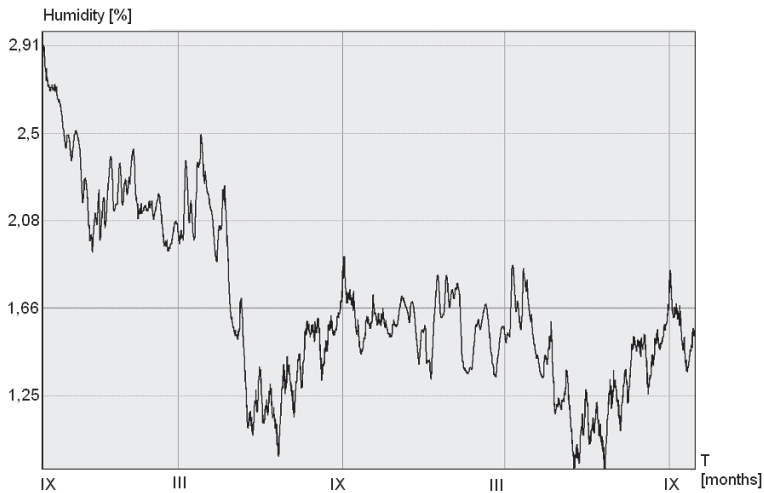

III. 6. Mineral wool humidity changes in the wall made of reinforced concrete structure and limestone cladding

transfer coefficient assumed as  $U \approx 0,25$  [ $W/(m^2K)$ ]. As a result of the computational analysis, the use of granite stone cladding for the climatic conditions of Cracow Poland is not recommended. Granite stone cladding, due to high water vapour diffusion resistance, causes condensation of moisture defused from the structure's interior at the wall and obstructs condensed moisture released from wall in the summer season. Particular stone type quality claddings usage capabilities to be glued directly to insulation layer are summarized in Table 3.

**Analyzed wall configurations with assumed wall heat-transfer coefficient  
of  $U \approx 0,25$  [W/(m<sup>2</sup>K)]**

Structural bearing layer/ thermal insulation	Cladding sort		
	Genesis, granite 1cm	Sandstone 2 cm	Hard limestone 1 cm
Structural bearing layer/ thermal insulation	–	+	+
“Porotherm” ceramic brick 25 cm /polystyrene 9 cm	–	+	+
Reinforced concrete 14 cm/ polystyrene 15 cm	–	+	+
“Porotherm” ceramic brick 25 cm /polystyrene 9 cm	–	+	+
“Ytong” aerated concrete 24 cm /polystyrene 9 cm	–	–	+
Reinforced concrete 15 cm/mineral wool 15 cm	–	–	+

Remarks: + sign denotes recommended usage  
– sign denotes not recommended usage

### 2.3. Influence of thermal insulation moisture on the facade operating service

Thermal insulation moisture should not influence the aesthetic aspect of a natural stone façade and in particular should not adversely impact its look. Stone cladding should be made of materials resistant to atmospheric factors. A stone cladding layer should be glued on cement mortar chemically neutral to natural stone. The main problem which should be taken into consideration is the change of the material’s mechanical properties. The long-term presence of water in the material according to [5], may affect the resins used to hold the fibres together. In that case, stone wool’s compressive and tensile strength values may be significantly weakened, leading to structural failures of part of the façade.

## 3. Conclusions

Directly glued to the thermal insulation layer, natural stone cladding technology implementation significantly reduced workmanship and overall cost of an architectonically attractive stone façade. Computational analysis has indicated some usage limitation of cladding made of granite due to multi-seasonal moisture accumulation in the building components. For practical applications the diffusion resistance coefficient value has to be checked for any particular stone type quality.

Analysis of water vapour diffusion resistance factors, conducted for the most popular sandstone in Poland, have indicated significant differences compared to data provided by [3]. The use of diffusion resistant value data provided by [3] may lead to high calculation inaccuracy.

For the purpose of analysis of the seasonal moisture condensation balance in the building component, the external air temperature is assumed as being based on meteorological statistical data. Walls made with stone facing are warmed up as a result of sun radiation and indicate capabilities to accumulate a considerable amount of heat. Cladding stone surface

temperature during the summer seasons reaches up to 70°C which improves the capability to dry condensed moisture [1].

Thermal insulation layer moistness impacts both its thermal insulation parameters and its strength parameters. Described moisture adversely affects particularly the mineral wool parameters. According to the research described in [5], mineral wool moistness causes high thermal conductivity coefficient reduction of even up to 38%.

In order to verify the conducted calculation and analysis of moisture transfer through the wall with stone cladding glued directly to the thermal insulation layer, a validation test in a climatic chamber should be made accordingly to the procedures provided in [4] or verified based on sophisticated numerical models.

*The work reported in this paper was partially funded by the project L-1/116/DS/2013 “Revitalization of existing buildings”. This financial support is gratefully acknowledged.*

## References

- [1] Balocco C., Grazzini G., Cavalera A., *Transient analysis of an external building cladding*, Energy and Buildings, No. 40, 2008, 1273-1277.
- [2] Byrdy A., *Okladziny kamienne ścian klejone bezpośrednio do warstw izolacji termicznej*, Izolacje 2/2010 143,40-42.
- [3] EN 12524:2000 Building materials and products – Hygrothermal properties – tabulated design.
- [4] Hens H., *The vapor diffusion resistance and air permeance of masonry and roofing systems*, Building and Environment, No, 41, 2006, 745-755.
- [5] Karamanos A., Hadiarakou S., Papadopoulos A.M., *The impact of temperature and moisture on the thermal performance of stone wool*, Energy and Buildings, No. 40, 2008, 1402-1411.

ANDRZEJ CHĄDZYŃSKI\*

## THE HYGROTHERMAL ASPECTS OF FORMING THE INTERNAL STRUCTURE OF THE ROOF SLOPE

### HIGROTHERMICZNE ASPEKTY KSZTAŁTOWANIA WEWNĘTRZNEJ STRUKTURY SKOŚNEJ POŁACI DACHU

#### Abstract

The system of external, sloping construction barriers protecting the bearing structure and the building's interior from the influence of environment's adverse weather conditions is one of the crucial elements of interior's thermal and acoustic protection. The steep roof effectively protects the interior against rain, snow, and wind. Proper thermal and damp-proof protection of the attic's microclimate space enclosed by the roof plane requires the application of new materials, which permit the system to obtain technical and functional values complying with the contemporary requirements. The roof's plane structure requires the use of multilayered construction barrier functioning as an oblique outer wall.

*Keywords: roof, layers, building physics*

#### Streszczenie

System skośnych, zewnętrznych przegród budowlanych, chroniących konstrukcję nośną i wewnątrz budynku od wpływu niekorzystnych warunków atmosferycznych otoczenia, jest jednym z istotnych elementów ochrony termicznej i akustycznej wnętrza. Stromy dach skutecznie chroni przed deszczem, śniegiem i wiatrem. Właściwa ochrona cieplna i przeciwwilgociowa, zamkniętej dachem przestrzeni mikroklimatycznej poddasza, wymaga wprowadzania w strukturę połaci dachowej nowych materiałów pozwalających na uzyskiwanie przez ten ustrój wartości techniczno-użytkowych odpowiadających współczesnym wymaganiom. Konstrukcja skośnej połaci dachu wymaga zastosowania wielowarstwowej przegrody pełniącej funkcję pochyłej ściany zewnętrznej.

*Słowa kluczowe: dach, warstwy, fizyka budowli*

---

\* Ph.D. Eng. Andrzej Chądzyński, Department of Construction and General Building Engineering, Faculty of Architecture, Wrocław University of Technology.

## 1. Introduction

The roof plane, functioning as an oblique outer construction barrier, has become an element of the complicated internal structure. It is composed of several layers of properly selected materials installed in a proper sequence. These layers provide thermal insulation, protect the interior as well as the roof structures against wind, external and internal moisture. They also insulate the habitable attic acoustically. This paper attempts to present the possibilities of forming the internal structure of this kind of construction barrier in connection with the hygrothermal processes that take place in it. The exchange of heat, water vapor and condensate between the environments of different temperatures and relative humidity separated by the barrier is a natural process. It is impossible to eliminate it completely. However, the excessive loss of heat from the thermally insulated interior can be significantly reduced by introducing the products and materials which poorly conduct heat in the internal structure of the barrier. The structure of the thermal insulation materials, which are applied today, can be cellular, made of grain, fibers, plates or it can combine those. These are solid substances where empty spaces between particles, fibers or plates are filled with damp air or another gas. The thermal insulation properties of empty spaces in the construction material depend to the great extent on the heat conductivity of the gas filling the pores. The right thermal insulation properties of this group of products can be formed by the porosity of the material. The mechanism of the heat flow in a damp and porous construction material, where it was assumed that no moisture migration occurs, takes place as a result of a few concurrent physical phenomena, including [1]:

- heat conducting through the material's structure, the damp air filling its pores and the capillary water adhered to the pore walls,
- heat convection through the damp air filling its pores,
- heat emission or absorption as a result of the phase transformations of water inside the pores,
- heat transfer through radiation inside the pores.

The description of the phenomena is further complicated with the assumption that water vapor diffuses simultaneously with heat exchange through the structure of a material. It can change its state of aggregation along with the change of temperature on the face of a material or inside it. The roof plane insulating the microclimatic interior can be composed of the following layers:

- windtight or watertight roofing,
- roof bearing construction, functioning as an underlay (sometimes also watertight) and as windtight diaphragm installed from outside,
- system of ventilation gaps,
- layer of thermal insulation,
- diaphragm protecting against wind and adverse effects of the water vapor diffusion,
- barrier's internal finish.

The rafters are the elements supporting the roof planes with traditional timber framing.

## 2. Thermal insulation

In pitched roofs above habitable attics, the thermal insulation material is placed inside the roof planes. The application of material solution is considered effective as long as it complies

with the requirements in that respect imposed by the provisions regarding the thermal insulation of buildings [2]. At present, the heat transmission ratio  $U$  for insulated roof planes should not exceed  $0.25 \text{ W/m}^2 \text{ K}$ . It is expected that in 2020 that ratio can reach in Poland  $0.12 \div 0.15 \text{ W/m}^2 \text{ K}$ . Consequently, the thermal insulation in the roofs providing protection for habitable attics, can be installed above the system of rafters, between rafters; filling the empty spaces their full height or partly their height, under the rafter. Future stricter regulations on thermal insulation of buildings shall result in the necessity of a more popular application of solutions including the use of mixed insulation systems in design practice, such as above and in between rafters or in between and under rafters. The thermal insulation should be placed in the roof plane in such a way as to provide for its ventilation.

### **3. Ventilation of the roof**

The design mistakes and imperfections in the roof plane workmanship result in some amount of air and water vapor that can penetrate through gaps. The exchange of air and water vapor through the materials of the barrier will grow along with the increase in porosity of their internal structure. As a result of differences in pressure, caused by wind or the differences in air density around the building as well as in ventilation gaps (thermal uplift), the air filling them is in constant motion. The motion of the air in ventilation gaps intensifies the convective heat exchange. Furthermore, it provides for the water vapor, condensation water and moisture of the building shell to escape from the roof plane.

### **4. Ventilation air ducts**

The roof ventilation is greatly affected by its construction and properties of the materials of breathable roof underlay. The roof with a layer of thermal insulation should be protected against rain water, snow or condensation water that gathers on the inside surface of roofing and which can penetrate through the roofing gaps. The condensate also forms when the water vapor diffusing through the structure of the barrier reaches the state of complete saturation. The ventilation of the roof also alleviates the effects of excessive roof overheating caused by the absorption of direct and diffuse solar radiation. The most effective method of elimination of excessive moisture of the internal structure of the barrier is the removal of the excess of water vapor and condensate by its efficient ventilation. The air flowing through the ventilation gaps carries out the excess of moisture. Drying its interior, it improves the thermal insulation of the structure. The most susceptible places in the barrier are considered to be those where a lot of condensation water can gather as a result of insufficient airing. The ventilation of a thermally insulated pitched roof is composed of a system of air gaps below the roofing layer. Two basic solutions of such a ventilation are applied in design practice [3, 4]:

- one-gap ventilation, where the water vapor and the condensate together are carried out of the roof with air through one gap located between counterbattens and the underlay membrane installed directly on insulation,
- two-gap ventilation, which is applied with underlay foil or membrane of low vapor permeability or a layer of waterproof barrier installed on rigid roofing.

The lower ventilation gap dries the thermal insulation and the timber structure of the roof. The upper one provides an escape passage for the water, which in the form of volatile snow and slanting rain with wind got under the roofing. It also provides a passage for the condensate forming under the roofing. The roof plane with poor windtightness does not eliminate the exchange of air that takes place between the surrounding and the space under the roofing. The air is exchanged here through joints between the elements of roofing, which are not tight on the whole roof plane. A tight roofing is most often made of overlapping strips of materials connected with sealing joints or with other tight joints. A tight roofing is installed on a rigid base (e.g. boarding.) In this case the air exchange is minimal. The ventilation gaps function correctly as long as the air filling them can pass through them continuously. The recommended air gap height is at least 3 cm. The height of the ventilation gap can prove insufficient in the case when the insulation material can expand after it was installed. The growing thickness of the fibrous material can fill in the clearance and result in its inefficient ventilation. In pitched roofs, the temperature measured directly in the ventilation ducts can be up to 15 K higher than the temperature of ambient air [4]. When the roofing is not heated with solar energy, the ventilation air can begin to move in the opposite direction, from the roof ridge to the eaves. This is what comes about in the roofs, which are constantly in shade or are oriented to the north. It is also possible at night when the roofing is cooled as a result of heat radiating from its surface. The air gaps of greater height should be installed in the roofs with short ventilation channels or when the roof pitch is low.

### **5. Protection of the roof against moisture caused by changing weather conditions**

Water in various forms is always present in both environments separated by a roof. This is why the internal structure of a roof can be damp from outside or from inside. The protection of a roof on the inside then comes down to eliminating or reducing the effects of moisture on the materials or products built into it. The critical levels of moisture, resulting in the excessive condensation depositing inside an element, are destructive for the material. They also deteriorate its thermal properties. The critical levels of moisture can occur when:

- the material of good sorptive properties is subject to moisture caused by rain water blown into the structure from a side of waterproof roofing,
- the relative humidity of air in contact with the layer of the material of low temperature reaches the value of complete saturation,
- the beginning of the in-depth condensation process takes place near the layer made of material which does not demonstrate sorptive properties, which results in the deposition of condensate on the surface of that layer,
- the material of the layer, which can absorb water, is in an environment whose temperature reaches the level at which the in-depth condensation process begins.

In such a case, empty spaces in the internal structure of the material filled earlier with air and water vapor are also filled with condensation water. Consequently, the following layers protecting the inside of the structure against moisture should be built into the roof:

- waterproof or watertight roofing system,
- underlay or waterproof barrier,
- vapor barrier.



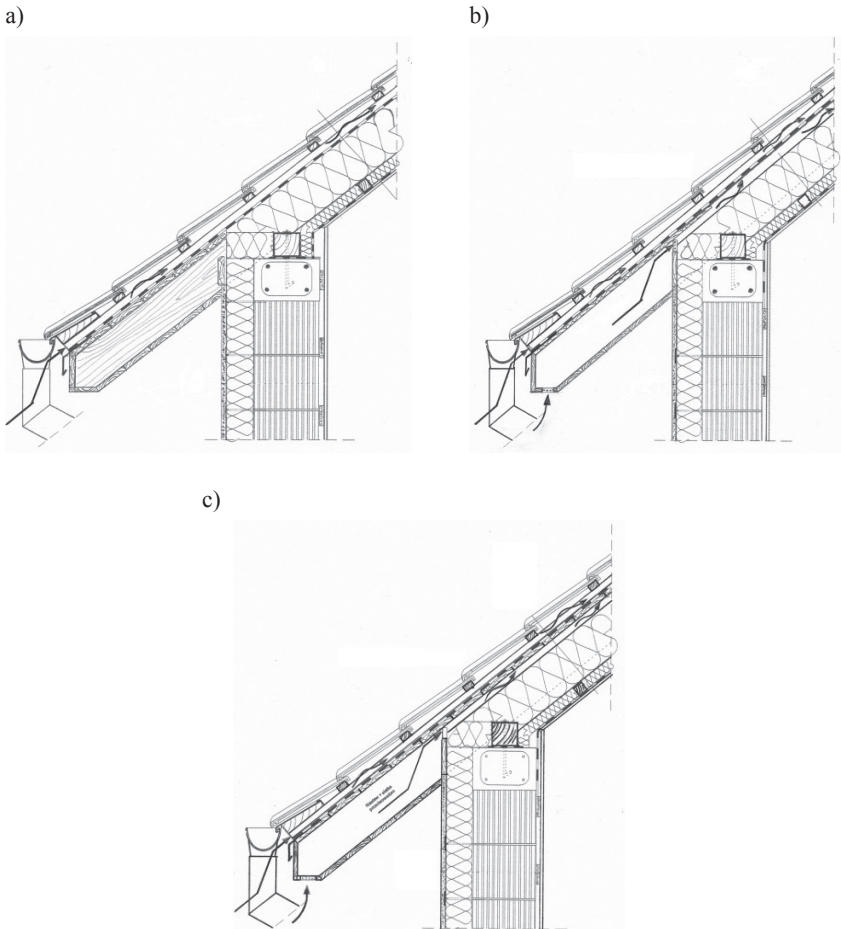

III. 1. A roof with thermal insulation and: a) one ventilation gap, b) two ventilation gaps, c) two ventilation gaps and a rigid roofing (by author)

## 6. Roofing foils and membranes

Every thermally insulated pitched roof requires measures protecting its interior against rain water, snow, and dust blown from the roofing as well as against air penetration and the effects which can be caused by the water vapor diffusing through the barrier. In adverse thermal conditions, it changes into condensate. Excessive moisture is destructive to built-in materials and it reduces their thermal performance. The elements of the structure protecting the roofing and thermal insulation include roofing foils and membranes. The lack of breathable roof underlay as well as vapor barrier and windtight foil can result in a more intensive exchange of air; also through the porous material of the barrier. Consequently, the convective exchange in the heat and water vapor transmission process will be greater.

Roofing foils and membranes vary in their internal structure and technical properties. Their water vapor permeability is especially important. Due to that material's feature, roofing foils and membranes can be divided into three subgroups:

- vapor-proof foils of very high diffusion resistance,
- foils and membranes of low vapor permeability,
- membranes of high vapor permeability.

The first of those subgroups includes traditional vapor-proof foils, which block the supply of water vapor to the layers protected by a vapor barrier – primarily to the layer of thermal insulation. The products from each of those subgroups are built into the roof plane in different places. The proper structure of other layers and their materials enables a foil or membrane to perform effectively.

## **7. Breathable roofing underlays**

An underlay should be placed from the external side of a building under its roofing system. Breathable foils and membranes can feature different technical properties. Their desired material properties are however, always closely connected with their position in the internal roof structure. The technical properties of the breathable roofing underlay are determined among others by the roof ventilation system. The parameters specifying the basic technical properties of breathable foils and membranes include: vapor permeability, resistance to water penetration, grammage (areal weight), resistance to longitudinal, lateral, and nail tear, fire resistance, resistance to UV radiation, the range of admissible use temperatures. Furthermore, when the producers present the characteristic features of foils or membranes, they additionally describe where they can be used [5].

The foils and membranes with low vapor permeability can be applied where there is a ventilation gap designed above a layer of thermal insulation. In such cases, there is an additional ventilation gap between an underlay and the bottom of the roofing system.

A breathable roofing underlay of high vapor permeability can be applied directly on a layer of thermal insulation. With such a solution only one ventilation gap can be used above an underlay and the layer of thermal insulation can be placed on the full height of the rafters, thus it can be much thicker. The multilayered breathable foils, commonly known as membranes, among others control the processes connected with the diffusion and condensation of water vapor as well as with the deposition of condensate under the roofing. These diaphragms are made of several layers fused together. Their internal structure is composed of a network of properly formed channels. Water vapor passes smoothly through such a material and the water stops on its surface. Breathable foils with several layers demonstrate high mechanical strength. They are also resistant to low and high temperatures. Breathable membranes, which are used as waterproof underlays, enable small amounts of rain water to penetrate under the roof or condensate on the internal surface of the roof. They also provide a windtight barrier. The new generation breathable membranes are produced with the use of ultrasound layer fusion. A large amount of energy supplied to the place where the layers contact provides for a durable and precisely manufactured bond. The use of special bond template enhances the tear resistance of the membrane. The membranes produced with that method are mechanically strong and flexible as well as resistant to aging. The micropores which provide for the membrane high vapor permeability are uniformly passable all over its whole surface.

## 8. Vapor barriers

The thermal insulation of the roof is protected from the inside with a vapor barrier. Preventing or significantly slowing down the diffusion of water vapor, it minimizes the influence of adverse effects, which can be caused by condensation of that vapor in the layer of insulation. When choosing the type of vapor barrier, one should pay special attention to technical characteristics of the other layers of the roofing. The effects of the sequence in which the layers are installed in the barrier should also be considered. It is especially important whether the suggested system of layers and materials in the layers will be tight or open to diffusion. The efficiency of the structure is also affected by the ventilation of the roof. At present, on the market of building materials there are available vapor barriers with new technical characteristics which prevent or slow down the process of diffusion of water vapor in winter [5, 6]. They also allow for drying out the inside of the barrier in summer as there are high temperatures outside of the habitable attic. A good example of such a barrier is a vapor barrier which actively reacts to the diffusion of water vapor. Water vapor penetrates through such a vapor barrier and thermal insulation open to diffusion outside only in such an amount, which can pass through the structure of the breathable underlay. In such a case the breathing underlay is installed directly on the insulation layer.

Another type of a new generation vapor barrier is the one, which apart from preventing the diffusion of water vapor in winter allows for guiding water vapor inside from the barriers in the summer. Its internal structure allows for so called reverse diffusion in which water vapor passes continuously in the direction from the roofing heated in the summer to its colder parts located near the thermally insulated interior. The reverse diffusion would be impossible if there was a traditional vapor barrier with a very high diffusion resistance on the colder side of the interior in summer. Such a solution would cause condensation in the place of contact between thermal insulation and traditional vapor barrier. It can prove especially dangerous when rain water gets inside the roof or water from condensation deposits there.

Still another type of a new vapor barrier is a membrane with a polyamide layer which actively reacts to humidity changes in relation to air which is on both sides of the vapor barrier. Due to the reversible changes taking place in the polyamide, its diffusion resistance is active and it can change the direction in which water vapor flows in winter and in summer. As a result of such characteristics of the barrier the polyamide vapor barrier causes it to dry inward in summer.

## 9. Conclusions

The structure with ventilation gaps above thermal insulation still seems to be an efficient solution for habitable attics. The air gap, which allows for ventilating the thermal insulation from the top enables the water penetrating the structure through a perforated waterproof layer to escape. It also enables the water vapor, which condenses from the air in the ventilation gap or in the thermal insulation layer to escape. Furthermore, it drives off the initial moisture in the building shell and hot air in the ventilation gap in hot summer. The roofs with a ventilation gap seem to be a more reliable solution when the vapor barrier is not installed carefully or its type is selected incorrectly. The system of sloping construction barriers transferring heat

and water vapor should be hard to penetrate for the air. It regards the internal structure of the materials of barriers and joints between individual elements as well as installation penetrations. When the air movement through the barriers is too intensive, it contributes to excessive convective heat loss. Too tight systems of external construction barriers can however, result in a significant deterioration of the microclimate of the insulated interior because the tighter the structure, the greater the threat of interior moisture. Currently, the reason of that problem seems to be the lack of ventilation or its defective operation. Additional threat of moisture on the barrier is created by the warm ventilation air with a lot of water vapor, which can condense under adverse thermal conditions. The breathable roofing membranes open to diffusion and modern active vapor barriers with varied functions facilitate driving off moisture from inside the structure. The underlay, which does not prevent the diffusion of water vapor, facilitates the diffusion exchange in the reverse direction. The stream of diffusing water vapor is then directed from hot roofing to a colder room.

*Thank for translation to Tadeusz Szalamacha*

## References

- [1] Stefańczyk B. et al, *Budownictwo ogólne*, Vol. 1, *Materiały i wyroby budowlane*, Arkady, Warsaw 2006.
- [2] Korzeniewski W., Korzeniewski R., *Warunki techniczne dla budynków i ich usytuowania*, Polcen Spółka z o. o., Warszawa 2013.
- [3] Klemm P. et al, *Budownictwo ogólne*, Vol. 2, *Fizyka budowli*, Arkady, Warsaw 2006.
- [4] Chądzyński A., Piróg M., *Wybrane problemy projektowania warstw występujących w dachach skośnych z tradycyjną więźbą dachową*, [in:] *Problemy remontowe w budownictwie ogólnym i obiektach zabytkowych*, edited by J. Jasieńko et al, Dolnośląskie Wydawnictwo Edukacyjne, Wrocław 2006.
- [5] Schunck E., Oster H.J., Barthel R., Kiefl K., *Atlas dachów. Dachy spadziste*, translated by Machalski A., mdm sp. z.o.o., Cieszyn 2005.
- [6] Chądzyński A., Piróg M., *Połączenie dachowa dachu skośnego kryta blachami płaskimi lub łupkiem*, Przegląd Budowlany, No. 5, May 2013, 30-34.

JACEK DĘBOWSKI, KATARZYNA NOWAK, KATARZYNA NOWAK-DZIESZKO\*

## AIRTIGHTNESS OF THE LARGE PANEL BUILDINGS BEFORE AND AFTER THERMAL MODERNIZATION

### SZCZELNOŚĆ BUDYNKÓW WIELKOPŁYTOWYCH PRZED I PO TERMOMODERNIZACJI

#### Abstract

The airtightness measurements of the system buildings are very important. They allow, together with the infrared tests, to verify all undesirable system joint leaks, which significantly increase the heating energy needs. In the article the results of airtightness measurements of two flats, built in system W-70, were presented. One of the buildings is after thermal modernization. During the leakage tests the system joints were monitored with the infrared camera. Thermograms, presented in the paper, confirmed the assumption about the negative influence of joints on the total building airtightness. Described tests are a pilot studies of the problem and provide the starting point to the further measurements on the statistical level.

*Keywords: building airtightness,  $n_{50}$  coefficient, large panel buildings, system buildings, panel joints*

#### Streszczenie

Badanie szczelności wykonywane w budynkach systemowych ma niebagatelne znaczenie. Pozwala bowiem, obok badań termowizyjnych, na zweryfikowanie wszelkich niepożądanych nieszczelności złączy systemowych, które w poważnym stopniu zwiększają zużycie energii na cele ogrzewcze. W artykule przedstawiono wyniki badania szczelności dwóch lokali mieszkalnych, wzniesionych w systemie W-70, w którym jeden został poddany zabiegom dociepleniowym. W trakcie badań szczelności monitorowano również miejsca występowania złączy systemowych przy użyciu kamery termowizyjnej. Termogramy przedstawione w artykule potwierdziły przypuszczenia o znaczącym wpływie tych niewrażliwych punktów konstrukcji na całkowitą szczelność budynku. Opisane testy są pilotażowymi badaniami i stanowią punkt wyjścia do badań statystycznych.

*Słowa kluczowe: szczelność budynków, wskaźnik  $n_{50}$ , budynki wielkopłytowe, złącza systemowe*

\* Ph.D. Eng. Jacek Dębowski, Ph.D. Eng. Katarzyna Nowak, M.Sc. Katarzyna Nowak-Dzieszko, Institute of Building Materials and Structures, Faculty of Civil Engineering, Cracow University of Technology.

## 1. Polish national requirements regarding airtightness measurements

At present per Polish building legislation airtightness measurements are not obligatory. According to national standard *Rozporządzenie w sprawie warunków technicznych, jakim powinny odpowiadać budynki i ich usytuowanie* [1], it is recommended that all detached buildings, commercial building, as well as industrial buildings and all building joints between walls and connections between windows and building envelope should be designed and erected to ensure the total airtightness.

However Polish regulations recommend the airtightness measurements and determining of  $n_{50}$  coefficient, which describes the number of air changes per hour at 50 Pa pressure difference. The recommended maximum values of  $n_{50}$  are as follows:

- a) For buildings with natural ventilation  $3,0 \text{ h}^{-1}$ ,
- b) For buildings with forced ventilation  $1,5 \text{ h}^{-1}$ .

Building measurements are very rare and conducted mainly in the new buildings. In practice no one make air leakage tests in the existing buildings before and after different modernizations, for example: thermal modernization.

## 2. Airtightness measurements according to PN-EN 13829

The airtightness measurements should be conducted according to standard PN-EN 13829 “Thermal performance of buildings. Determination of air permeability of buildings. Fan pressurization method” [2].

In the standard two different methods are acceptable depending on the purpose:

- a) Method A – test of the building in use,
- b) Method B – test of the building envelope.

In both methods all openings in the building envelope such as windows, doors, chimney ducts should be closed. While all interconnecting doors within the building should be opened during the entire air leakage test. All heating systems taking air from the outside, mechanical ventilation and air conditioning must be turned off. The open chimneys should be cleaned of ash. All air intake and exhaust mechanical ventilation, and air-conditioning ducts should be sealed. Openings for natural ventilation should be opened in case of method A and closed in case of method B.

What is significant, *Warunki Techniczne* does not precise, which method described by the standard should be used during tests, that is why usually they are conducted using both methods.

## 3. System large panel buildings – scale of the problem

It is estimated that in Poland about 4 million buildings are made of prefabricated elements in different systems. Moreover, at present more than 10 million Poles live in system large panel buildings. It makes the problems connected with the proper usage and thermal insulation to be very important and common. The most important aspect is the improvement of the

building energy certificate of those buildings. It is connected with the thermal modernization of the building envelope and change of the windows.

Considering and designing the thermal modernization no one takes into consideration the discontinuity of the envelope, including joints between panels and material changeability of the vertical sections. What is more none controlling tests, airtightness or insulation improvement in the building/flat, are conducted after adding of thermal insulation.

In Poland conducting of airtightness tests in existing and modernized buildings is very rare, especially in case of prefabricated large panel buildings. Described tests are a pilot studies of the problem and provide the starting point to the further measurements on the statistical level.

#### 4. Analyzed flats in the system buildings

Taking into account the facts above the authors conducted the airtightness measurements in two different flats located in the W-70 system buildings. The tests were conducted using the Blowerdoor set (Ill. 1) with the digital controller Retrotec 3000 and Fantestic program to analyze test data.



Ill. 1a. Blowerdoor set the in the Flat number 1



Ill. 1b. Blowerdoor set the in the Flat number 2

The first tested flat is located at the first level of the five-storey block of flats before thermal modernization (Ill. 2a) but with the new windows. It is a three room corner flat with the separate kitchen and bathroom, total area 53,4 m<sup>2</sup>.

Second flat is located on the seventh floor of the eleven-storey block of flats after thermal modernization (Ill. 2). It is also a three room corner flat with kitchen and bathroom and with the new windows, total area 49 m<sup>2</sup>.





III. 2a. Building #1 – North-East elevation



III. 2b. Building #2 – East elevation

The measurements were conducted in the following weather conditions:

- Building number 1 – external air temperature 15°C, wind speed in Beauford scale based on the own observation, 2 (light breeze – wind felt on exposed skin, leaves rustle); air temperature inside the flat 20°C;
- Building number 2 – external air temperature 18°C, wind speed in Beauford scale based on the own observation, 1 (light air – leaves and wind vanes are stationary); air temperature inside the flat 22°C.

Tests were conducted in two different methods. In method A, test of the building in use, the ventilation openings were not sealed. In method B, all ventilation openings were closed. During the airtightness measurements the thermal bridges and system joints were monitored using thermal camera.

Test results of both methods, for particular buildings, are presented respectively in Tables 1 and 2 and in III. 3 and 4.

In both buildings, 1 and 2, number of air changes  $n_{50}$ , in case of method A is much higher than permissible value of 3 h<sup>-1</sup>; in building 1 value of  $n_{50}$  is almost 200% higher. However in case of method B, number of air changes, in building 1 is about 27% lower than permissible value, in building B about 40%. The difference between methods is directly connected with the dynamic air flow through the ventilation ducts. Nevertheless, the influence of system joint leaks is clearly noticeable in the tests' results.

Table 1

#### Results of airtightness test of the flat number 1

	Method A	Method B
Number of air changes at 50 Pa, $n_{50}$ [1/h] <b>pressurisation</b>	5.800	2.345
Number of air changes at 50 Pa, $n_{50}$ [1/h] <b>depressurisation</b>	5.715	2.045
<b><math>n_{50}</math> [1/h]</b>	5.757	2.195

Table 2

## Results of airtightness test of the flat number 2

	Method A	Method B
Number of air changes at 50 Pa, $n_{50}$ [1/h] <b>pressurisation</b>	5.215	1.785
Number of air changes at 50 Pa, $n_{50}$ [1/h] <b>depressurisation</b>	5.595	1.770
<b><math>n_{50}</math> [1/h]</b>	5.405	1.777

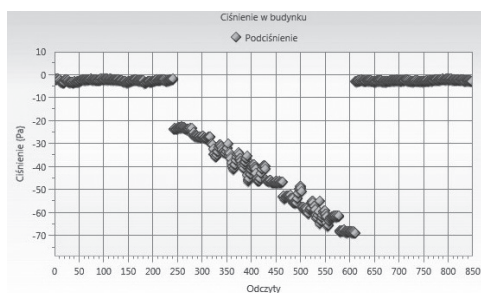

III. 3a. Diagram of pressure difference in building 1 – depressurization test

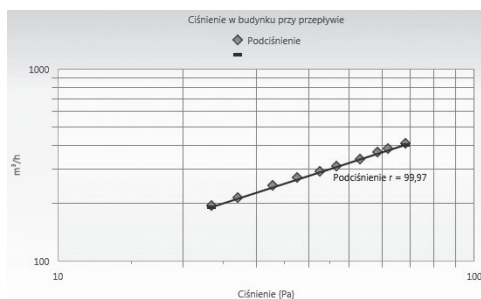

III. 3b. Relation between air flow and pressure difference in building 1

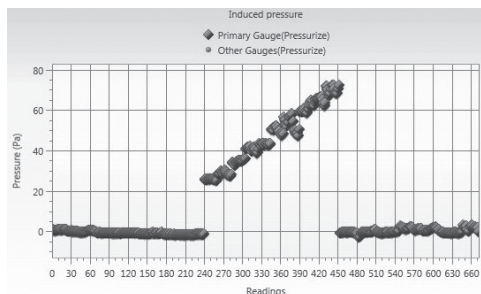

III. 4a. Diagram of pressure difference in building 2 – pressurization test

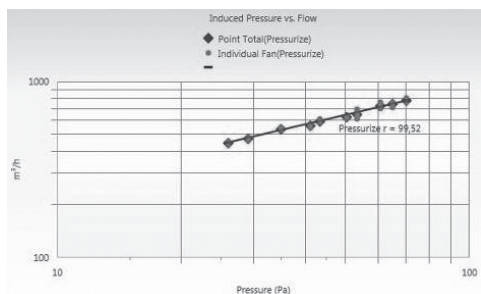

III. 4b. Relation between air flow and pressure difference in building 2

Based on the results of both tests it can be noticed that in both methods values are lower for building after thermal modernization. It proves that the use of thermal insulation eliminates discontinuities at system joints and improves the airtightness.

During the tests, the system joints in the not insulated building number 1, were monitored. In this flat, on the external walls, the vertical scratches caused by the presence of the system joints could be observed (III. 5 and 6). Due to the low temperature difference between the internal and external environment, only about 5°C, the infrared analysis were impeded.



Ill. 5. System joint in building number 1 – external view

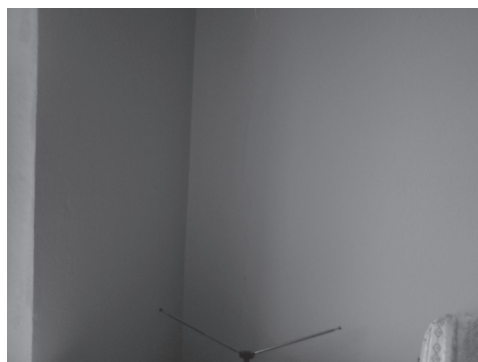
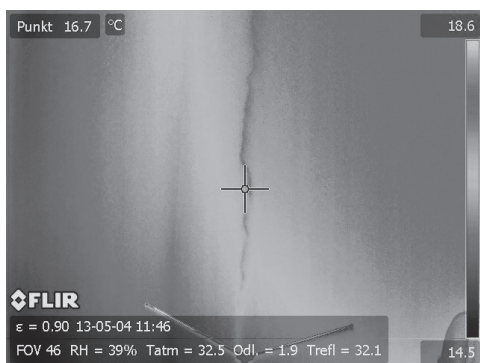

Ill. 6a. System joint – leak in place of vertical joint in building number 1



Ill. 6b. System joint – leak in place of vertical joint in building number 1

To make the monitoring possible and to increase the air flow through the joints the condition of 100 Pa underpressure was forced. It revealed the other system joint leaks: connection between floor and external wall, connections of windows, results presented in Ill. 7 and 8.



Ill. 7. Thermal bridge – connection between floor and external wall in building number 1



Ill. 8. Thermal bridge – connection between window jamb and external wall in building number 1

## 5. Conclusions

The conducted tests in the system buildings prove the high airtightness of the building envelopes. Results from method B in both flats were lower than the maximum acceptable values per Warunki Techniczne [1]. It is probably the result of the very precise construction of building 1 (correctly done connections) and the thermal insulation of the envelope of building 2. What is more in both building the originally mounted windows were replaced with the new ones. Nevertheless, due to the method B, number of air changes per hour in building 1 is 20% higher comparing to building 2. In case of method A, with the open ventilation ducts, the results are much higher than acceptable, in building 1 almost twice higher than maximum permissible value.

Comparing the results received in method B, it can be noticed that the leaks caused by panel joints lower the building airtightness, while the envelope insulation significantly eliminates those leaks. However the influence of the windows replacement should be taken into consideration. This problem will be the next step of the authors' researches.

The separate issue is the ventilation type and efficiency in this kind of buildings. Based on the test results it can be assumed that the amount of air removed through the ventilation ducts in system buildings is much higher than acceptable.

The measurements were conducted only in two different flats, in two different buildings. Authors plan to do much more tests in different flats and analyze the data on a statistical level. The achieved results cannot be compared with any similar test results as similar measurements have not been conducted in the prefabricated large panel buildings.

## References

- [1] Rozporządzenie Ministra Infrastruktury w sprawie warunków technicznych, jakim powinny odpowiadać budynki i ich usytuowanie z dnia 12 kwietnia 2002.
- [2] PN-EN 13829 Właściwości cieplne budynków. Określenie przepuszczalności powietrznej budynków. Metoda pomiaru ciśnieniowego z użyciem wentylatora.
- [3] PN-EN 15242 Wentylacja budynków – Metody obliczeniowe do określania strumieni objętości powietrza z uwzględnieniem infiltracji.
- [4] Kim A.K., Shaw C.Y., *Seasonal Variation in Airtightness of Two Detached Houses*, American Society for Testing and Materials, Philadelphia 1986, 17-32.
- [5] Shaw C.Y., Jones L., *Air tightness and air infiltration of school buildings*, ASHRAE Transactions VOL. 85, part 1, 1979, 85-95.
- [6] Nowak K., Nowak-Dzieszko K., *Badania szczelności budynków metodą ciśnieniową*, Czasopismo Techniczne, 2-B/2012, 305-313.
- [7] Ligęza W., Dębowski J., *A method of non-destructive evaluation of construction defects in precast concrete panel housing*, 5<sup>th</sup> International Conference, Concrete and Concrete Structures, 15–16 October 2009, Žilina, Slovakia.
- [8] Dębowski J., *Cała prawda o budynkach wielkopłytowych*, Przegląd budowlany, 9/2012.
- [9] Dębowski J., *Typowe uszkodzenia w budynkach wielkopłytowych*, Przegląd budowlany, 10/2012.



HALINA GARBALIŃSKA, MAGDALENA BOCHENEK\*

## THE DETERIORATION OF STRENGTH AND THERMAL PROPERTIES OF AUTOCLAVED AERATED CONCRETE AS A RESULT OF CAPILLARY MOISTURE

---

### POGORSZENIE WŁAŚCIWOŚCI WYTRZYMAŁOŚCIOWYCH I CIEPLNYCH BETONU KOMÓRKOWEGO W WYNIKU ZAWILGOCENIA KAPILARNEGO

#### Abstract

In modern construction there appear two parallel independent trends. On the one hand, large emphasis is put on raising durability of construction works implemented through the selection of appropriate materials with parameters tailored to the specific conditions occurring during the operation of the building. On the other hand, great importance is attributed to the problem of energy-efficient building design, which is reflected in the increasingly stringent records of existing legislation. In this paper some questions were raised concerning the both issues. The article presents the results of autoclaved aerated concrete studies, in particular, the deterioration of its strength and thermal conductivity due to moistness.

*Keywords: capillary transport, thermal conductivity, strength, autoclaved aerated concrete*

#### Streszczenie

We współczesnym budownictwie obserwuje się niezależne występowanie dwóch równoległych trendów. Z jednej strony kładzie się duży nacisk na podniesienie trwałości realizowanych obiektów budowlanych, poprzez dobór właściwych materiałów, o parametrach ściśle dostosowanych do specyficznych warunków występujących w trakcie eksploatacji obiektu. Z drugiej strony dużą wagę przywiązuje się do problemu energooszczędnego projektowania budynków, co znajduje swój wyraz w coraz bardziej restrykcyjnych zapisach obowiązujących aktów prawnych. W ramach niniejszego artykułu podjęto kwestie dotyczące obydwu zagadnień równocześnie. Przedstawiono mianowicie wyniki badań dotyczących betonu komórkowego, a w szczególności pogorszenia jego wytrzymałości i przewodności cieplnej w wyniku zawilgocenia.

*Słowa kluczowe: przepływ kapilarny, przewodność cieplna, wytrzymałość, beton komórkowy*

---

\* Prof. Ph.D. Eng. Halina Garbalińska, M.Sc. Eng. Magdalena Bochenek, West Pomeranian University of Technology, Faculty of Civil Engineering and Architecture, Szczecin.

## 1. Introduction

The economic, technical and ecological aspects tend to be the reasons for constructing the buildings which are distinguished by their satisfying durability as well as energy efficiency of used solutions, e.g. structural and material ones. Exterior walls of the buildings play a major part in fulfilling these requirements. Sensible choice of the appropriate building materials to be used for constructing the partitions requires full awareness of their physical and mechanical properties. These properties may undergo strong oscillations depending on the intensification of factors affecting them, e.g. moistness. Thermal conductivity and compressive strength of the building materials are the elementary parameters that determine the suitability of materials used to build the exterior partitions. Dry construction materials show, however, different characteristics when exposed to moisture. One of the major causes of the exterior partitions moistness is capillary rise. As a result of capillary forces water penetrates the pores of the material, causing deterioration of its physical and mechanical properties. Along with an increase of moistness the coefficient of thermal conductivity rises too, while the material's compressive strength concurrently falls [1, 10, 11].

This paper shows the elements of the process and the outcomes of a two-phased experiment focused on defining the matter exemplified by the autoclaved aerated concrete. In the first stage of the experiment a simulation was performed in which the partitions made of various kinds of autoclaved aerated concretes are exposed to a liquid water penetration as a result of capillary forces. Such situation may occur as a result of a bad project, leading to an appearance of condensation inside or on the surface of the partition. It may also emerge as a consequence of a faulty performance, such as lack of or improper installation of the waterproofing. It can also be caused by the installation failures or natural disasters, for example as an effect of flood waters [12]. After a 3 month simulation period, during which water spread through the pores of the tested material, an examination was performed. It established the basic stage of the experiment which aimed at testing on how water spreading through the partition thickness changed the distribution of strength and thermal parameters inside each wall made of concrete of a range of different densities.

## 2. Experiment

### 2.1. Testing of the capillary sorption coefficient

The experiment aiming at assessing an impact of capillary moisture on the thermal and strength parameters was conducted in an air-conditioned laboratory at the constant temperature of +20°C. Four samples of concrete blocks were selected for the purpose of conducting the experiment: 400, 500, 600, and 700 density class, produced by one manufacturer. They create a testing material, which was used as a basis for determining the coefficient of capillary sorption which was utilised as a measure of intensity of the process of a material porous structure water penetration. As described in [6] a selection of sorption measuring methods can be used. For the purpose of this study a mass method for sorption measurement was adopted.





III. 1. Measurements of water sorption coefficients

Four samples were prepared for the first stage of testing. The four samples were cuboids measuring  $12 \times 12 \times 24$  cm each. The samples were insulated along their side walls by a silicon layer in order to ensure a one-way water transport, as well as to prevent it from uncontrolled drying up through the sides. With relation to all considered samples an initial mass, geometric measures and base volumetric density were established. Once prepared and inventoried, the samples were placed in a dish filled with distilled water (III. 1). Throughout the entire period of testing the samples remained submerged in distilled water to exactly the same depth that equalled around 2 mm. The research was conducted by a gravimetric analysis method and was based on systematic measuring of the mass of the samples which were weighted on the 0.01 g accuracy scales. The process run relatively fast in its initial stage, therefore the measurements of subsequently changing mass were taken once every hour. Along with the declining intensity of the process, the intervals between the consecutive measurements were increased to 4 h, 8 h and finally to 12 h.

## 2.2. Measurement of thermal conductivity coefficients

After the three month period of the experiment each sample, measuring  $12 \times 12 \times 24$  cm was cut in two to form two cubes measuring  $12 \times 12 \times 12$  cm. These were named respectively ‘top’ (the top cube exposed to a direct contact with surrounding air), and ‘bottom’ (lower cube exposed to a direct contact with water). Once prepared as per given description, the samples were first used to measure the thermal conductivity coefficient  $\lambda$ . It was a non-stationary method which was chosen to ensure a relatively quick accomplishment of the measurements, as opposed to long-lasting stationary measurements that could have had some impact on the changes of the tested samples moistness. The testing was conducted by the use of a portable measuring instrument ISOMET 2104 equipped with appropriately selected surface probes.

Each measurement was performed twice, and the result was automatically recorded by the measuring instrument, as shown in III. 2.



III. 2. Measurement of thermal parameters

### 2.3. Measurement of compressive strength

Soon after the measurements of the thermal parameters were completed, the measurements of the compressive strength commenced. In order to perform this experiment a material testing machine was used, as shown in III. 3.



III. 3. Measurement of compressive strength

Before the commencement of compressive strength testing each individual sample was weighted and measured. Next, each sample was one by one put inside the machine. The testing involved an even application of compressive force to each sample where the compression was set to have an axial and perpendicular orientation towards the surface. Strength, measured in  $\text{N}/\text{mm}^2$  was then read from the screen of the machine. Compressive strength  $f_b$  was being marked according to the standard [8].

## 2.4. Test results and analysis

Testing of the capillary sorption facilitated the preparation of graphical illustration of changes to the masses of individual samples in relation to the area of contact with water in a function of the square root of time. Ill. 4 shows a diagram containing four graphs prepared on the basis of average values recorded during measurement process of all four classes of autoclaved aerated concrete blocks.

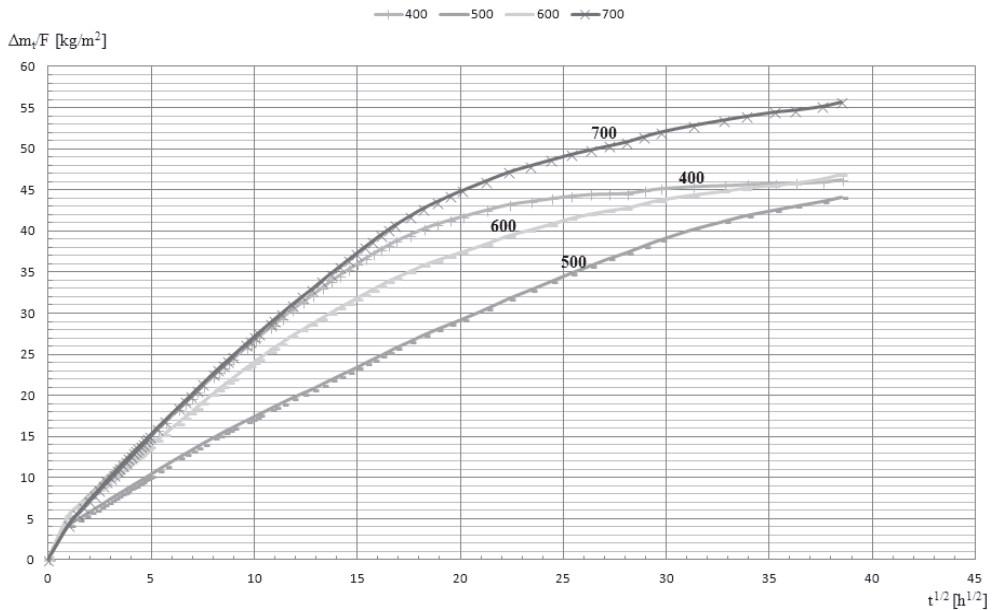

Ill. 4. Diagram  $m_s = f(\sqrt{t})$  for aerated concrete of 400, 500, 600, 700 kg/m<sup>3</sup> density

In accordance with PN-EN ISO 9346 standard [7] capillary coefficients of water sorption A was determined by using the following formula:

$$m_s = A \cdot \sqrt{t} \quad (1)$$

where:  $m_s$  is the mass of the absorbed water in relation to the area of contact of the sample and water ( $\Delta m/F$ ), and  $t$  denotes time of the process.

Having analyzed the graphs, it was observed that for all tested classes of autoclaved aerated concrete blocks there occurred a high level of compatibility between the description illustrated by the formula (1) and actual course of the process. The occurrence of a linear correlation  $m_s = f(\sqrt{t})$  was noted in a relatively long period of time. Similar results were obtained for all individual samples in a course of a 1 month long experiment [2, 5].

Measurements performed by means of using Isomet 2104 instrument and those conducted inside the material testing machine enabled to assess the impact of capillary moisture on the thermal conductivity and compressive strength within the group of the tested autoclaved aerated concretes. A range of factors which were tested in works, e.g. [3, 4, 7] influence the coefficient of thermal conductivity. Predominant value is assigned to moistness, in particular the one that penetrates the available porous space of the material in liquid phase. For this reason this work endeavours to assess a degree of the unfavourable impact of spreading capillary moisture on unwanted fall in strength and increase of thermal conductivity. The average values obtained from measurements of blocks of all concrete density classes are shown in Ill. 5.

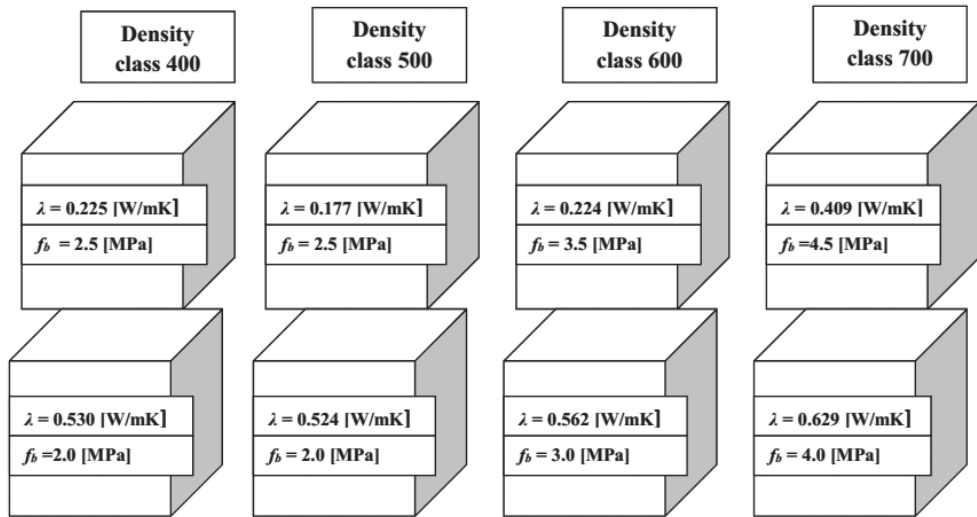

Ill. 5. Schematic diagram of  $12 \times 12 \times 24$  cm AAC block division of cube samples  $12 \times 12 \times 12$  cm with their thermal conductivity coefficient  $\lambda$  and the compressive strength  $f_b$  in various water saturations

Every 'bottom' cube is characterised by decreased average compression strength in relation to the 'top' one. Nevertheless, the recorded falls in strength are located on a level of around 25% in the case of two concretes of the lowest density, at a level of 17% in the case of class 600 concrete, and at 12.5% in the case of the highest density concrete, 700. Moreover, the average value of thermal conductivity coefficient for the 'bottom' samples of autoclaved aerated concrete class 400 and 600, which was determined by the performed measurements, is 2.5 times greater compared to the 'top' samples; for class 500 it is three times greater and for class 700 it is 1.5 times greater.

### 3. Conclusions

The research proved that applying a load of capillary water to a partition wall affects negatively its properties by causing changes to its thermal insulating properties, as well as it

causes a decrease of its compressive strength. It needs to be stressed that these regularities occur in relation to all tested density classes of autoclaved aerated concrete: 400, 500, 600 and 700.

In each case the thermal conductivity coefficients  $\lambda$ , obtained by the use of the non-stationary method show unequivocal tendency to increase thermal conductivity along with the increase of the material moistness. Greater moistness of the area located in a direct contact with water, compared with the opposite drier sides, leads to an increase of the thermal conductivity in a range from around 300% to around 150%. These unfavourable changes to the insulation parameters occur along with a decrease in the compressive strength in the range of 25% to 12.5%. The both lower limiting values relate to the autoclaved aerated concrete class 700 which was the least affected by destructing influence of capillary water. However, even in the case of the highest density concrete, the technical parameters determining energy-efficiency and durability of the partitions undergo a serious deterioration. It goes without saying that the utmost care should be taken when choosing suitable material and construction solutions in order to prevent the walls from the occurrence of water inside the partitions, regardless of its source.

## References

- [1] Autoclaved aerated concrete. Properties, Testing and Design. RILEM Technical Committees 78-MCA and 51-ALC, 1993.
- [2] Bochenek M., Garbalińska H., *Zmiany parametrów cieplnych betonu komórkowego wywołane kapilarnym zawilgoceniem przegrody*, XIV Polska Konferencja Naukowo-Techniczna Fizyka budowlanej w Teorii i Praktyce, Łódź–Słok 2013.
- [3] Garbalińska H., Siwińska A., *Badania wpływu zawilgocenia materiałów ściennych na ich współczynnik przewodzenia ciepła*, Inżynieria i Budownictwo, nr 11/2011.
- [4] Garbalińska H., Siwińska A., *Warunki pomiaru a wartość współczynnika przewodzenia ciepła*, Zeszyty Naukowe Politechniki Rzeszowskiej, Budownictwo i Inżynieria Środowiska, Zeszyt 57, nr 4/2010, Rzeszów 2010.
- [5] Garbalińska H., Bochenek M., *Wpływ podciągania kapilarnego na przewodność cieplną betonu komórkowego*, Inżynieria i Budownictwo, nr 5/2013.
- [6] Pietrzak K., Kubissa J., Kubissa J., Banach M., *O metodach pomiaru sorpcyjności betonu*, Inżynieria i Budownictwo, nr 11/2011.
- [7] PN-EN ISO 9346:2009 Ciepłno-wilgotnościowe właściwości użytkowe budynków i materiałów budowlanych. Wielkości fizyczne dotyczące przenoszenia masy. Słownik.
- [8] PN-EN 772-1:2011 Metody badań elementów murowych – Część 1: Określenie wytrzymałości na ściskanie.
- [9] Siwińska A., Garbalińska H., *Zależność współczynnika przewodzenia ciepła betonu komórkowego od warunków wilgotnościowych*, Inżynieria i Budownictwo, nr 5/2008.
- [10] Suchorab Z., Barnat-Hunek D., *Analiza przewodności cieplnej przegród z betonu komórkowego w zależności od zmian wilgotności*, Budownictwo i Architektura 8, 2011, 107-116.

- [11] Trochonowicz M., Witek B., Chwiej M., *Analiza wpływu wilgotności i temperatury powietrza na wartość współczynnika przewodności cieplnej  $\lambda$  materiałów termoizolacyjnych stosowanych wewnątrz pomieszczeń*, Budownictwo i Architektura 12(4), 2013, 165-176.
- [12] Trochonowicz M., *Wilgoć w obiektach budowlanych. Problematyka badań wilgotnościowych*, Budownictwo i Architektura 7, 2010, 131-144.

TADEUSZ KAMISIŃSKI\*, ROMAN KINASH\*\*,  
ADAM PILCH\*, JAROSŁAW RUBACHA\*

## THE INFLUENCE OF NEW MATERIAL TECHNOLOGY ON ACOUSTIC TREATMENT OF MODERNIZED INTERIORS

### WPŁYW NOWYCH TECHNOLOGII MATERIAŁOWYCH NA ADAPTACJĘ AKUSTYCZNĄ MODERNIZOWANYCH WNĘTRZ

#### Abstract

The paper deals with the problem of the acoustic treatment using modern material technology in the modernization of old interiors. On the example of an auditorium with approved acoustics, that was built in 1962 and is located at the Lviv Polytechnic, some important directions in handling this type of object was shown. The acoustic measurements of the room showed, that structures used in the 60s are acoustically proper, but planned renovation should be based on modern technologies.

*Keywords: acoustics, speech intelligibility STI, reverberation time, Lviv Polytechnic*

#### Streszczenie

W artykule podjęto zagadnienia modernizacji wnętrz o uznanej akustyce z użyciem współczesnych materiałów. Jako przykład wybrano przygotowywaną do remontu salę audytoryjną Politechniki Lwowskiej (bud. 1962). Przeprowadzone badania akustyczne wykazały poprawność istniejących rozwiązań, jednak projektowane zmiany muszą opierać się na współczesnych technologiach posiadających odmienne właściwości.

*Słowa kluczowe: zrozumiałość mowy STI, czas pogłosu, Politechnika Lwowska*

\* Ph.D. D.Sc. Eng. Tadeusz Kamisiński, Ph.D. Eng. Adam Pilch, Ph.D. Eng. Jarosław Rubacha, AGH University of Science and Technology, Department of Mechanics and Vibroacoustics.

\*\* Prof. Ph.D. Eng. Roman Kinash, AGH University of Science and Technology, Department of Geomechanics, Civil Engineering and Geotechnics; Lviv Polytechnic, Department of Architectural Constructions.



## 1. Introduction

The main goal of the paper is to analyze the influence of materials and technology used in the acoustic treatment of interiors, that were used in the 60s of the XX century and those used nowadays. The research was made in a multi-purpose room built in 1962 and owned by Lviv Polytechnic. The room is used mainly as an auditorium for 800 people. It is a classical shoe-box in shape with dimensions of  $35.5 \times 24.0 \times 9.7$  m (Ill. 1a, b). The volume of the room is about  $6100 \text{ m}^3$ . At the rear wall of the room and along the side walls, there is a balcony. The side walls on the lower level (below the balcony) consist mainly of windows. Above, there are balcony railings and again windows. The auditorium consist of benches and chairs made of laminated plywood. On the ground floor, in the part closer to the stage, the auditorium is flat, while beginning from the middle of the room, the floor is sloped. That profile of the auditorium provides proper sight and listening conditions even in the most distant rows. Moreover, this type of floor limits the area of the back wall of the room, which reduces the possibility of an acoustic flow (like an echo) to occur. The ceiling was shaped in a specific way to provide proper transmission of sound to the most distant rows of the room and to

a)



b)

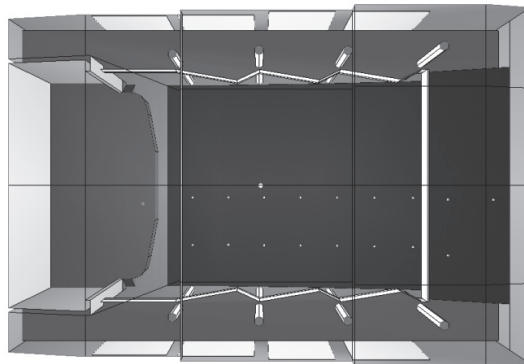

Ill. 1 a) Picture of the analyzed room, b) Visualization of the room in CATT-Acoustic software

the balcony; however, perforated steel plates used there and characterized by high sound absorption in the wide frequency band, reduce the effectiveness of the ceiling.

## 2. The measurement and analysis of the selected acoustic parameters

For the auditorium, which is made for verbal communication, the most important parameter is speech intelligibility, so in the further analysis, the Speech Transmission Index was investigated. The maximum value of STI is 1 (the best intelligibility) while the minimum is 0. Moreover, the reverberation time  $T_{20}$  was measured and calculated as the most important acoustic parameter of each interior.

The present acoustic conditions of the room were measured based on standard procedure [1]. It should be noted, that during measurement, the auditorium was without audience. Introducing listeners into the room has a great impact on the room's total absorption [2], which influences the reverberation time and speech intelligibility. That is why the evaluation of the room is always made for the room with an audience. In order to calculate the acoustic parameters of the room with people, there was an acoustic model made in CATT-Acoustic software [3, 4].

The input parameters of the model was the geometry of the room obtained from its technical documentation, the sound absorption and scattering coefficients of the materials used in the interior. The model was validated based on the measured reverberation time in the room.

The evaluation of the acoustic parameters based on the results of measurements and numerical simulation showed that the reverberation time for different frequencies are comparable for low and mid frequency range, while the average value of reverberation time is equal to  $T_m = 1.33$  s, which is slightly more than recommended for that type of room (III. 2)

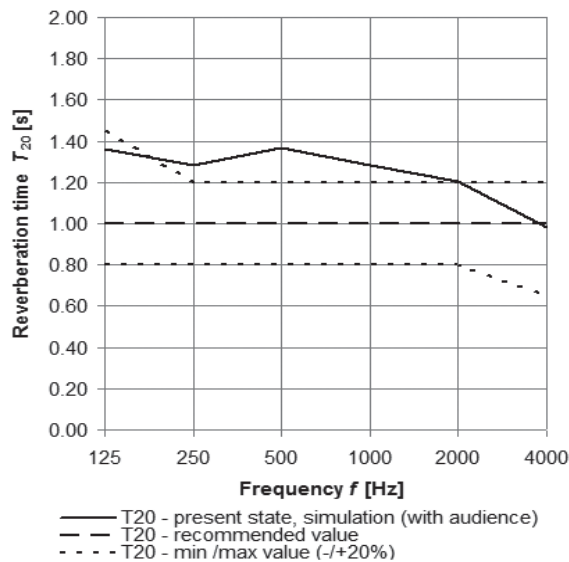

III. 2. The evaluation of the reverberation time frequency characteristic of the auditorium filled with listeners. The values were calculated in the CATT-Acoustic software

According to the recommendation of Rettinger [5], it was assumed that for the 6100 m<sup>3</sup> auditorium with an audience, the reverberation time should be equal to  $T_m = 1.00$  s. Calculated values of the Speech Transmission Index for the room with an audience are between 0.56–0.69, with an average value of 0.61. This means, that speech intelligibility for the audience in most of the area is good. Only in the middle of the room, are there lower values of STI, where the speech intelligibility is average.

### 3. The design of the modernization of the room using new material technology

The aim of the analysis was to formulate acoustic guidelines for the project of auditorium modernization. The main assumption was to reduce the reverberation time to the values recommended in the literature ( $T_m = 1.00$  s) and to improve speech intelligibility. Because of the fire protection and inaccessibility of the original materials used in the interior, the new acoustic treatment was based on modern material technology.

Based on the numerical model, several computer simulations of the acoustics inside the room were made, which led to proper material selection and the proposition of their optimal placement. Thanks to that calculation, it was possible to obtain the best possible acoustic parameters in the room. Details of the arrangement of materials inside the room and their acoustic proprieties are shown in the Ill. 3 and Tab. 1.

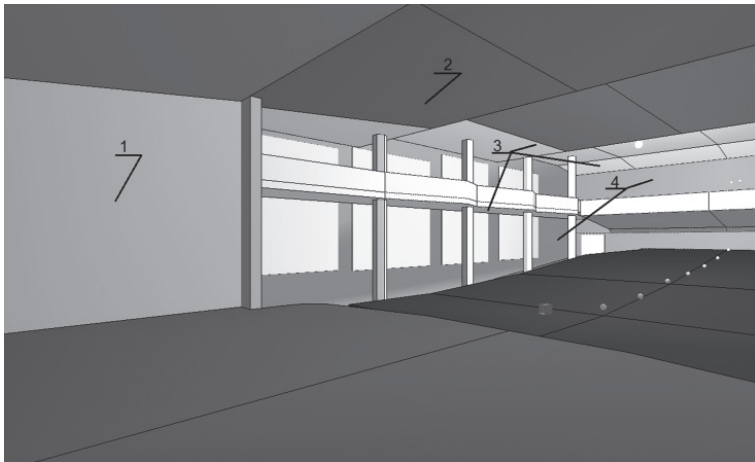

Ill. 3. Arrangement of new materials inside the auditorium

The selected project of acoustic treatment, proposed the replacement of the ceiling finishing material. Perforated steel plates should be replaced by perforated gypsum boards and a stone or glass wool acoustic ceiling. As it was shown in the literature [6], the sound reflected from the ceiling to the listeners has an enormous meaning in the reception of the acoustic quality of a room. That is why a lot of work was made during the designing of the ceiling in the described room.

On the available surfaces of the rear wall below, on the balcony and on the side walls below the windows, perforated gypsum-fiber plates should be used. The sound absorption coefficient of all new materials used in room are presented in Table 1.

Table 1

**Sound absorption coefficient of materials used in the acoustic treatment of the room**

No.	Material description	Sound absorption coefficient $\alpha$					
		125 Hz	250 Hz	500 Hz	1000 Hz	2000 Hz	4000 Hz
1	Laminated gypsum-fiber plate, 30 mm, ODS = 62.5 mm	0.11	0.04	0.03	0.03	0.04	0.05
	Gypsum board with grouped square perforation and acoustic coating at rear, ODS = 62.5 mm	0.45	0.50	0.45	0.35	0.30	0.30
3	Glass wool acoustic ceiling, ODS = 200 mm	0.50	0.75	0.80	0.95	0.95	0.95
4	Laminated gypsum-fiber plates with round perforation, $\phi 8$ mm, mineral wool 30mm, ODS = 62.5 mm	0.37	0.80	0.99	0.90	0.70	0.57

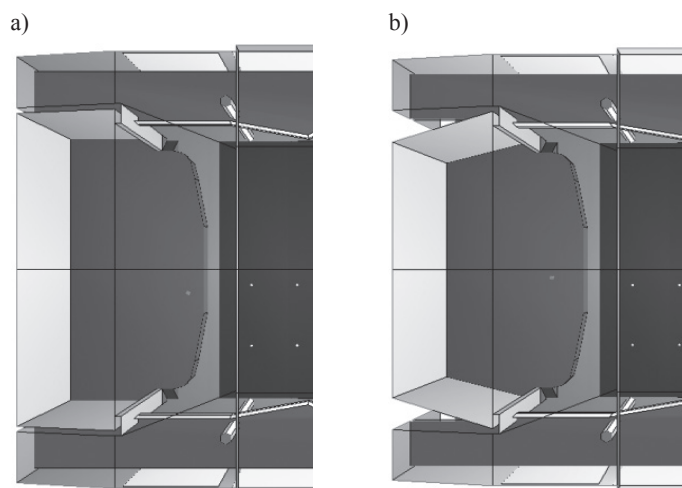

III. 4. The correction of the side and rear wall of the stage

In the scope of the modernization of the room, the stage was completely rearranged. Curtains hanging on the stage were replaced with gypsum-fiber plates and the geometry of the stage's side walls was changed to provide better sound transmission to the audience (III. 4).

This solution will also eliminate the flutter echo on the stage. Moreover, putting sound reflector arrays above the stage was considered to shorten the initial time delay gap (time between the direct sound and the first reflection) [7, 8], but this solution was rejected by the architect.

For the selected acoustic treatment of the auditorium, acoustic simulations were made. Comparison of frequency characteristics of reverberation time in the present state and after modernization is shown in Ill. 5. One can see that the new treatment reduced reverberation time; the average value for 500 and 1000 Hz frequency band after modernization will be 1.01 s instead of 1.33 s in the present state. Moreover, the reverberation time for every frequency band will be almost equal especially for mid and high frequencies. Reduction of reverberation time is an effect of increased absorption of the wall, especially at the rear of the room. Shorter reverberation time will provide better speech intelligibility, listening conditions and the general comfort in using the room.

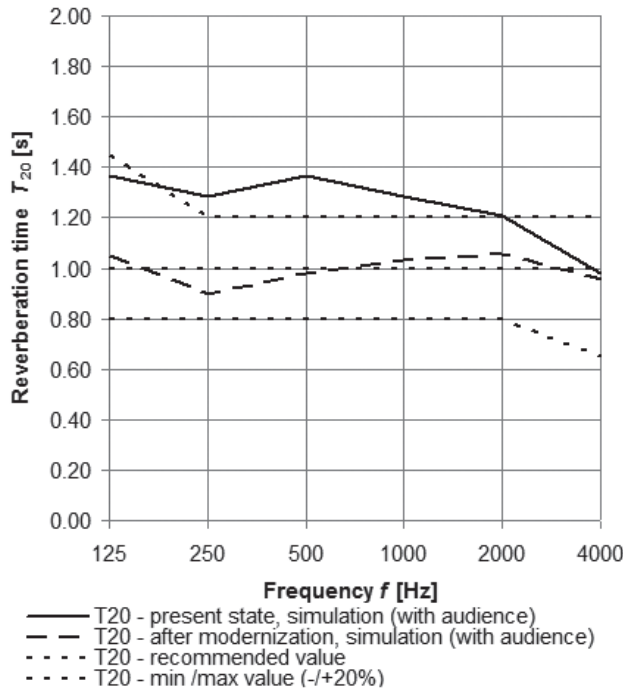

Ill. 5. Comparison of reverberation time before and after modernization of Lviv Polytechnic auditorium. Results according to CATT-Acoustic software

Numerical calculation of speech transmission index showed that for selected solutions of acoustic treatment, STI will be higher than in the present state. Obtained values are in the range of 0.60–0.71, with an average value of 0.64. This means, that in the whole audience area, the speech intelligibility will be good.

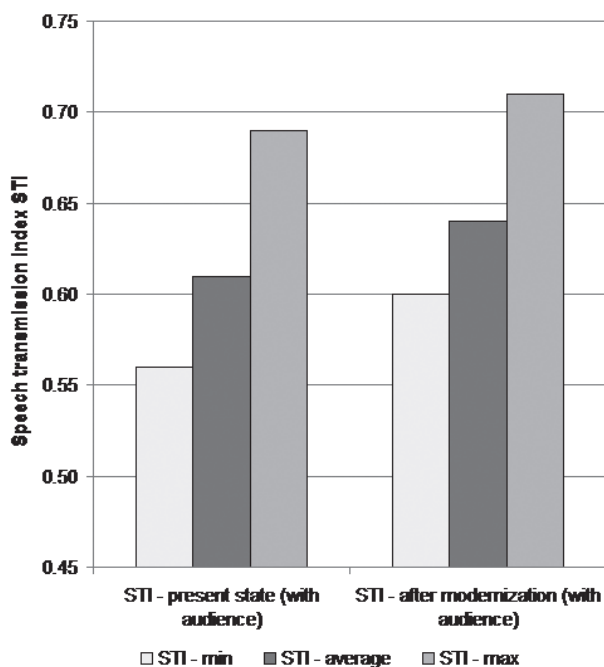

III. 6. Comparison of speech transmission index STI before and after modernization. Results acc. to CATT-Acoustic software

#### 4. Conclusions

The analysis of acoustic parameters in the present state of Lviv Polytechnic auditorium built in the 60s of the last century show, that the room has an excessively long reverberation time according to the literature recommendation. On the other hand, flat frequency characteristics of reverberation time provide good speech intelligibility in most parts of the audience.

Because of the planned renovation of the room, multi-optional simulation of acoustic parameters in CATT-Acoustic software were made. Several different solutions were considered based on new material technologies. Selected acoustic treatment will reduce reverberation time and improve sound transmission from the stage to the audience. Reducing reverberation time was possible because of higher acoustic absorption of the wall at the rear and side part of the ceiling, rear wall and ceiling above the balconies. High absorption in the wide frequency band will be obtained by an acoustic ceiling made of glass wool. Better sound transmission to the rear of the room will be provided because of the replacement of perforated steel plates by carefully selected perforated gypsum-board. The new materials used in the project of the stage will have a great impact on the sound transmission, especially to the places below balconies [9]. Because of the changed geometry of the stage, it will be free from acoustic faults like flutter-echo.

## References

- [1] EN ISO 3382-1:2009 Acoustics – Measurement of room acoustic parameters – Part 1: Performance spaces.
- [2] Rubacha J., Pilch A., Zastawnik M., *Measurements of the Sound Absorption Coefficient of Auditorium Seats for Various Geometries of the Samples*, Archives of Acoustics, vol. 37, 4, 2012, 483-488.
- [3] Kamisiński T., *Acoustic Simulation and Experimental Studies of Theatres and Concert Halls*, Acta Physica Polonica A, vol. 118, 1, 2010, 78-82.
- [4] Kamisiński T., Burkot M., Rubacha J., Brawata K., *Study of the effect of the orchestra pit on the acoustics of the Kraków Opera Hall*, Archives of Acoustics, vol. 34, 2009, 481-490.
- [5] Kulowski A., *Room acoustics* [in polish], Wydawnictwo PG, Gdańsk 2011.
- [6] Schroeder M.R., *Binaural dissimilarity and optimum ceilings for concert halls: More lateral sound diffusion*, J. Acoust. Soc. Am., 65, 4, 1979, 958-963.
- [7] Kamisiński T., Szeląg A., Rubacha J., *Sound Reflection from Overhead Stage Canopies Depending on Ceiling Modification*, Archives of Acoustics, 37, 2012, 213-218.
- [8] Kamisiński T., Szeląg A., Rubacha J., *Measurements of parameters of sound reflecting screens*, Mechanics and Control, 29, 2010, 174-178.
- [9] Kamisiński T., Kinasz R., Rubachą J., Pilch A., *Acoustical correction of under balcony cavities in Lviv Opera Hall* [in polish], Czasopismo Techniczne, 8-A/2010, 7-14.



TOMASZ KISILEWICZ\*

## ON RATIONAL DESIGN OF LOW ENERGY BUILDING EXTERNAL COMPONENTS

---

### O RACJONALNYM KSZTAŁTOWANIU NIEKTÓRYCH ELEMENTÓW OBUDOWY ZEWNĘTRZNEJ BUDYNKÓW NISKOENERGETYCZNYCH

#### Abstract

An attempt at the verification of simple designing rules of chosen building components is made in this paper, taking into account not only heating energy demand but also avoidance or at least reduction of cooling demand. Large south-oriented windows supply a large amount of solar energy and thus minimize the heating demand. Oversized windows and the resulting large energy gains, which are not accumulated in building's thermal capacity and used immediately for heating, do not reduce energy demand but create unbearable conditions or a big cooling load in living spaces. A green flat roof is today a very popular solution. Its insulating and dynamic properties have been evaluated.

*Keywords: low energy buildings, window area sizing, overheating, green flat roof*

#### Streszczenie

W artykule podjęto próbę weryfikacji prostych zasad kształtowania budynków niskoenergetycznych, zwracając przy tym uwagę zarówno na ograniczenia energii potrzebnej do ogrzewania jak i na uniknięcie przegrzewania wnętrza lub konieczności chłodzenia. Okna południowe pozwalają bowiem na bierno pozyskiwanie energii słonecznej, ale nadmierne przeszklenia prowadzą do wzrostu zapotrzebowania na ogrzewanie, a także stwarzają realne zagrożenie dla komfortu wewnętrznego. Poddano ocenie także izolacyjne i dynamiczne właściwości chętnie obecnie stosowanego rozwiązanie w postaci stropodachu zielonego.

*Słowa kluczowe: budynki niskoenergetyczne, powierzchnia okien, przegrzewanie, zielony stropodach*

---

\* D.Sc. Tomasz Kisilewicz, Division of Building and Building Physics, Institute of Building Materials and Structures, Faculty of Civil Engineering, Cracow University of Technology.

## 1. Introduction

Presently overheating is becoming nowadays a very important aspect of a building's use and a big part of the maintenance costs. It is relatively easy to minimize heating needs and usually the formal requirements are oriented to this aim. Because of the common pressure on energy saving, a designer may easily find information on how to decrease energy losses, maximize and efficiently use solar and internal heat gains. In these conditions it is relatively easy to decrease heating needs but also to increase overheating risk. The methods of how to protect buildings against overheating are not commonly known and understood because of the complicated dynamic aspects of heat flow and storage in the building shell. In winter, south oriented windows supply building space with solar gains proportional to window area. Oversized windows and the large resulting energy gains, not accumulated in the building's thermal capacity and used immediately for heating, do not reduce the energy demand as it was expected due to increased night energy losses. High temperature rise may create unbearable conditions or big cooling load in living spaces.

A flat roof, that is commonly used in public utility or commercial buildings, is in summer often a source of large heat gains because of extremely high external surface temperature. Solar radiation, intensively absorbed by the bituminous coating on a horizontal roof area and combined with high air temperature, results in high energy flux entering the building space.

Due to minimized thermal losses through a well insulated external shell and substantially decreased ventilation losses, the thermal balance of a low energy building is extremely sensitive to energy gains. That is why the new and more comprehensive procedures of rational design of external building components are needed today [1].

## 2. South oriented window area versus heating and cooling load

The basic research on south oriented window sizing took into consideration the following features of building shell and environment [2, 3]:

- local climate conditions (especially air temperature, solar radiation intensity),
- space heating load that depends on thermal resistance of the whole building shell, ventilation intensity, heat recovery and internal energy gains,
- space thermal capacity,
- thermal resistance and solar transmittance of glazing.

The relation between window area and demand on heating and cooling energy was investigated by means of computer simulation in the Energy Plus program. The whole simulated object may be one storey of a single-family building or a repeatable unit of a multi-storey residential or office building. Although the dimensions of the entire floor area of the simulated unit were  $10 \times 10 \times 3$  m, the main object of the simulation reported in this paper is the unit's south-west part only (modeled as a separate thermal zone), with floor dimensions  $5 \times 5$  m and a height of 3 m.

It was assumed that:

- variable high density internal layers are in good thermal contact with the space,
- the minimum internal air temperature is set at  $+20^{\circ}\text{C}$  and the maximum at  $+25^{\circ}\text{C}$ ,

- the measure of the passive system's thermal efficiency is the amount of purchased heating and cooling energy,
- considered heating period: 15.IX–15.VI, four computational time-steps per hour,
- ventilation rate: 1/2 air change per hour with highly efficient heat recovery (80%), no extra infiltration was assumed,
- standard apartment occupancy heat gains are constant in time,
- air or material humidity was not considered,
- seven thermal capacity variants were investigated, the first one (I) corresponds to lightweight technology with hardly any thermal mass (79.31 kJ per 1 K and 1 m<sup>2</sup> floor) and the last one (VII), is a massive building with 20 cm of concrete structure and additional internal walls (1919.40. kJ per 1 K and 1 m<sup>2</sup> floor)
- meteorological data for Kraków were used in computer simulations.

The curves displayed in Ill. 1, joining the separate data points obtained from the – simulations have been approximated using 5-th order polynomial regression.

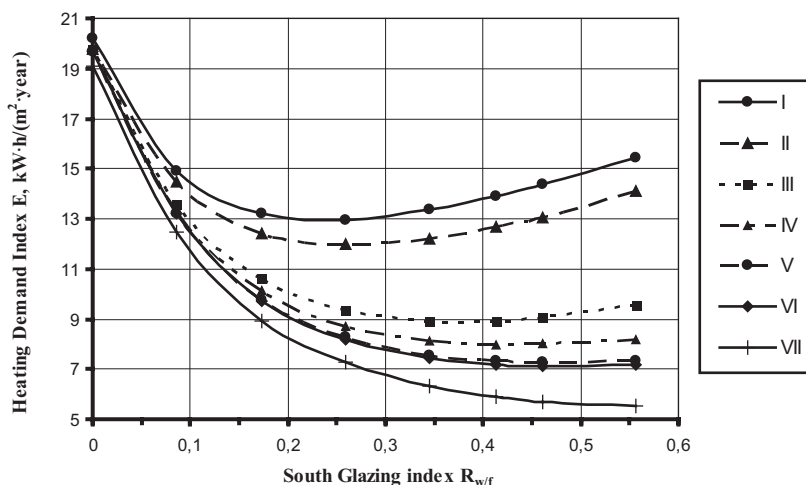

Ill. 1. Heating demand index of the south building space versus thermal capacity and south window area – passive house insulation standard with 80% ventilation heat recovery and LE triple glazing

It may be observed that well insulated south glazing may actually reduce the space heating demand. But what is very important, oversized windows in case of lightweight building structure would again increase the energy demand. It means that a simple and commonly used rule of the thumb by designers: “big window area of the south windows assures big savings of conventional energy”, is not always true. Available big solar gains do not necessarily become conventional energy savings. There is an optimum glazing index value for which space energy demand on heating would be minimized. In case of the lightweight buildings optimum window to floor ratio should be equal to 0.22 and for the massive buildings it even goes up to 0.57. For double glazed windows with a much higher than for triple glazing transmission of solar radiation, the values of optimum glazing index were much smaller [2, 3] than the ones above.

Data shown in Ill. 1 are oriented only on minimization of heating needs and include only demand on heating energy. In this sense they are adequate to the common approach today, where protection against overheating is usually not considered. In Ill. 2, combined energy demand on heating and cooling was presented for one capacity variant of a very massive building (case VI).

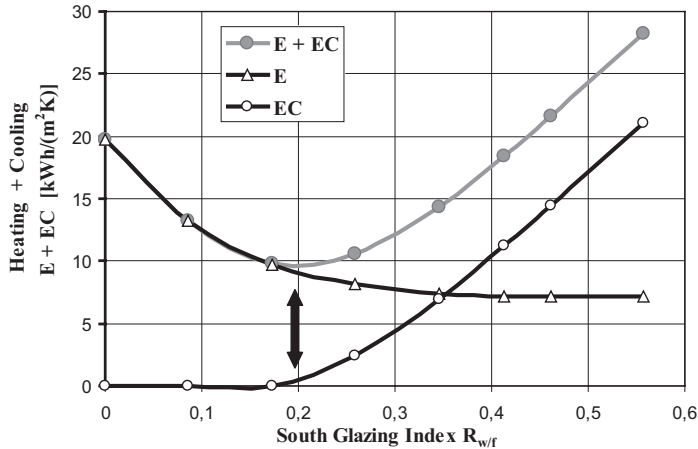

Ill. 2. Heating and cooling demand indices of the south building space versus south window area – passive house insulation standard with 80% ventilation heat recovery and LE triple glazing

Total energy demand minimum can in this case be achieved for glazing index value equal to 0.2 instead of 0.55 as it was suggested before. Oversized windows would induce enormous overheating in the analyzed zone or necessitate an intensive and energy consuming cooling process. An optimized window area would practically allow cooling to be avoided while keeping heating demand at a low level.

Rational design of the external building shell would in this case demand a comprehensive optimization of south oriented window area, considering the total demand on energy and various technical features of a building and its equipment. Such an approach is unfortunately not yet a standard procedure as decision regarding window size is usually subjective and has nothing to do with rational measures.

### 3. Dynamic thermal features of a flat roof

In large scale commercial or industrial buildings, the roof is very often the biggest component and the source of intensive solar gains. Solar energy gains via flat roof combined with internal gains may create a big dynamic cooling load and high demand on energy. Well insulated but lightweight (low thermal capacity) structure of the external shell does not ensure thermal comfort in internal space. Flat roof exposure to solar radiation on a summer day and a highly absorbing external coating, result in very high external surface temperature, inducing an intensive heat wave that flows across the roof. High thermal resistance of a contemporary

roof allows to damp down efficiently heat flux amplitude. However, a space under the roof would be effectively protected against overheating not only when the ceiling flux amplitude is minimized, but also when it is shifted in time up to the moment when ambient air temperature is significantly decreased. This effect is efficiently used as so called night cooling that improves thermal conditions within the space without substantial demand on energy. Expected minimum time lag for an apartment roof is 10 hours and in case of a cold store, even 12 hours [4].

The dynamic thermal characteristics of a building component describe the thermal behaviour of the component when it is subject to variable boundary conditions i.e., variable heat flow rate or variable temperature on one or both of its boundaries. In International Standard EN ISO 13786 [5], only sinusoidal boundary conditions are considered, building boundaries are submitted to sinusoidal variations of temperature or heat flow rate. Thermal transmittance is a complex quantity defined as the complex amplitude of the density of heat flow rate through the surface of the component adjacent to zone  $m$ , divided by the complex amplitude of the temperature in zone  $n$  when the temperature in zone  $m$  is held constant. Thermal transmittance  $Y_{ei}$  was used here as a concise description of a dynamic roof characteristic that includes information regarding amplitude ratio and time lag between the waves of external temperature and internal heat flow. The assumed time period is 24 h.

A typical lightweight roof structure was taken as a reference roof case: asphalt over and undercoat layers 1 cm, thermal insulation 5 cm, corrugated metal sheet 0.1 cm.

Thermal transmittance of the reference roof under steady state boundary conditions ( $U$  value) depends only on its thermal resistance. While under harmonious conditions the role of the combination of thermal diffusivity and resistance becomes important.

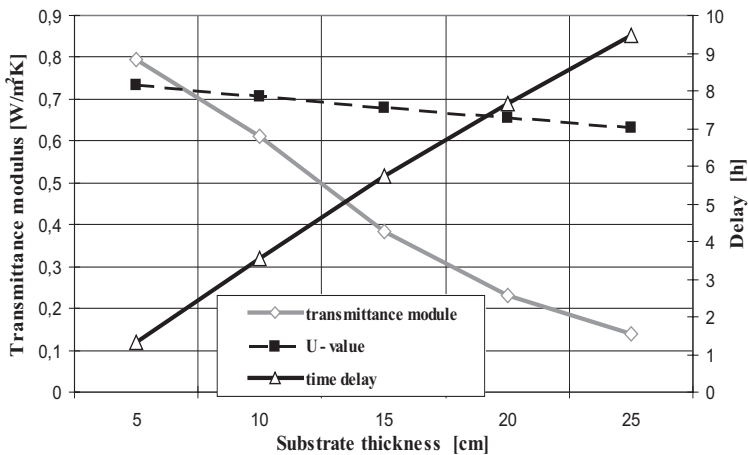

III. 3. Green roof transmittance versus substrate thickness, 5 cm of thermal insulation

Increased thermal resistance of a roof is not a sufficient measure to avoid overheating [4]. During a hot summer day ceiling heat flux amplitude will be significantly reduced, but its maximum will occur a few hours after the sun culmination, when ambient temperature is still very high. At this moment even a very small temperature rise would intensify thermal discomfort in the space. In this situation an expensive and energy consuming mechanical cooling is the only chance to reduce space overheating.

In Ill. 3, a poorly insulated lightweight roof was turned into a green roof with a substrate layer added on its top. A thick (25 cm) substrate layer with a density equal to  $1800 \text{ kg/m}^3$  is practically not increasing the thermal resistance of the roof (U value curve), but transmittance module reduction is significant and phase shift (delay curve) is 9.5 h. If the assumed solar culmination is at 13.00 (summer time), internal heat flux would reach its maximum at 22.30. At this moment ambient temperature is relatively low, even after a very hot summer day, and intensive ventilation would effectively reduce space overheating.

An intermediate 15 cm thick substrate layer (reduced mechanic load upon the structure) also improves also the dynamic features of the roof in a considerable way: transmittance module is  $0.39 \text{ W/m}^2\text{K}$  and phase shift ca. 6 h. In the case of an increase of up to 20 cm in thermal insulation and 15 cm substrate layer (diagram not included in this paper), phase shift would even be equal to 8.15 h.

#### 4. Conclusions

Low energy building design should be based on rational, optimized decisions regarding any component of the final product. Because of a low level of energy demand such a building is very vulnerable to unbalanced energy gains and overheating. The approach to total energy demand (heating, cooling) should be considered to avoid thermal discomfort or increased costs of building use. Appropriate window sizing procedure that takes into consideration various technical features of a building and is focused not only on heating needs, but also on overheating load, seems currently to be one of the most important tools for a building designer. In the case of some commercial or public utility buildings space, overheating could be avoided or at least reduced by conversion of a lightweight roof into a green roof due to its enhanced thermal capacity.

#### Acknowledgements

The work reported in this paper has been partially funded by the project L-1/115/DS/2013 "Building compatible with Sustainable Development". This financial support is gratefully acknowledged.

#### References

- [1] Keller B., Magyari E., *Ein Design-Tool für den Entwurf von Niedrigenergiebauten*, Bauphysik 28, Heft 5, 2006, 321-329.
- [2] Kisilewicz T., *Computer Simulation in Solar Architecture Design*, Architectural Engineering and Design Management, Volume 3, 2007, 106-123.
- [3] Kisilewicz T., *The Influence of Resistive, Dynamic and Spectral Features of the Building Walls on the Thermal Balance of the Low Energy Buildings* (in Polish). Kraków, Wydawnictwo PK, No. 364, 2008.
- [4] Kisilewicz T., *On attenuation of temperature oscillation by the enclosure of the building*, Czasopismo Techniczne, z 2-B/2012, Wyd. PK, Kraków 2012, 87-94.
- [5] European Standard EN ISO 13786/2007 *Thermal performance of building components — Dynamic thermal characteristics — Calculation methods*.

DOROTA KRAM, KATARZYNA NOWAK\*

## THE IMPACT OF DETAIL SOLUTIONS IN THE WOODEN BUILDING STRUCTURES ON THE THERMAL PARAMETERS OF THE ENCLOSURE

### WPŁYW ROZWIĄZAŃ DETALI W BUDYNKACH O KONSTRUKCJI DREWNIANEJ NA WARTOŚCI PARAMETRÓW CIEPLNYCH OBUDOWY

#### Abstract

As far as modern building technological and material solutions, wood-based constructions are more often applied. New technologies in wood constructions allow to design and construct buildings in low-energy and passive building standards. Producers of system solutions provide the catalogues of different system construction details. The aim of this article is the analysis of thermal bridges of different solution details of both, framework and massive board wood construction. The analysis was conducted in THERM 6.3 program, prepared by Lawrence Berkley National Laboratory. THERM enables to model the effects of two-dimensional heat flow effect and is based on finite elements method, which allows modeling of both simple and geometrically complicated building components. All the results of software calculation facilitates the analysis of the heat exchange and finally allows for the estimation of energy effectiveness. Analysis of local temperature values allows for assessment of condensation and mould growth problems.

*Keywords: thermal bridges, modern wood-based constructions*

#### Streszczenie

We współczesnych budynkach coraz częściej pojawiają się nowe rozwiązania technologiczno-materiałowe na bazie drewna. Nowe technologie o konstrukcji drewnianej pozwalają na konstruowanie obiektów spełniających standard budynków niskoenergetycznych, a nawet standardy budynku pasywnego. W celu zminimalizowania błędów producenci takich rozwiązań systemowych przygotowują w formie katalogowej rozwiązania detali. Celem niniejszego artykułu jest analiza mostków cieplnych dla różnych rozwiązań systemów konstrukcji drewnianych zarówno szkieletowych, jak i masywnych płytowych. Analizę przeprowadzono w programie THERM 6.3 opracowanym przez Lawrence Berkeley National Laboratory. Program umożliwia modelowanie dwuwymiarowych efektów przenoszenia ciepła w elementach budowlanych. Wyniki uzyskane z obliczeń programu umożliwiają analizę przenikania ciepła, a w konsekwencji pozwalają na ocenę efektywności energetycznej produktu, a możliwość obliczenia lokalnych wartości temperatury pozwalają na analizowanie problemów związanych bezpośrednio z kondensacją pary wodnej oraz działaniem wilgoci.

*Słowa kluczowe: mostki cieplne, nowoczesne konstrukcje drewniane*

\* Ph.D. Eng. Dorota Kram, Ph.D. Eng. Katarzyna Nowak, Faculty of Civil Engineering, Cracow University of Technology.



## 1. Introduction

The contemporary technological and material applications in wood-based constructions (1) discussed in the present article, show the solutions that may occur on the building market. Thanks to some of these technologies, there is possibility of fast and efficient assembly, which can lower costs and the time of construction process. However, the constructor must face restrictive demands of present thermal standard.

The Directive on the Energy Performance of Buildings, published in May 2010, obliges all union countries to make a commitment, that after 2021, all designed and constructed buildings should be almost zero-energy buildings.

In order to timely fulfil the obligations, the National Fund for Environmental Protection (NFOŚ) has introduced supporting programs, which should give the impetus for investors to meet the required low-energy NF40 and passive NF15 standards by all designed buildings. The conducted analysis has allowed to create a set of necessary requirements for keeping the usage of energy for heating and ventilation at levels of respectively 40 kWh/m<sup>2</sup>year or 15 kWh/m<sup>2</sup>year.

Table 1 presents examples of minimal requirements of the NFOS for single and multi-family houses.

Table 1

### Chosen demands for single and multi-family houses built by the Voivodship Fund for Environmental Protection and Water Management

No.	Demands	NF15		NF40
		Single family house/ multi-family house		
1	Building construction			
1.1	Boundary values of thermal transmittance $U_{max}$ (W/m <sup>2</sup> K)			
a)	Exterior walls	I, II, III climatic zone	0.10/0,15	0.15/0.20
		IV,V climatic zone	0.08/0,12	0.12/0.15
b)	Roofs, flat roofs, structural ceiling under no-heating attics	I, II, III climatic zone	0.10/0,12	0.12/0.15
		IV, V climatic zone	0.08/0,12	0.10/0.15
1.2	Value of linear thermal transmittance limits of thermal bridges' waste			
a)	Balcony panels		0.01/0.01	0.20/ 0.20
b)	Other thermal bridges		0.01/0.01	0.20/ 0.20
1.3	Building air tightness n50 (1/h)		0.60/0.60	1.00/1.00

One of the acts implementing the provisions of the Directive 2010/31 / EU are changes proposed by the Ministry of Infrastructure and Development introduced in the WT Regulations, *Warunki techniczne jakim powinny odpowiadać budynki i ich usytuowanie*. Those changes relate, inter alia, to the strengthening of requirements concerning the insulation of building envelopes. The tightening of those requirements will be carried out gradually between 2014 and 2021 (suggestions are presented in the Table 2).

Table 2

**Time schedule and chosen minimal demands for thermal transmittance factor  $U$  (W/m<sup>2</sup> K)**

Type of boundaries and temperature inside		Thermal transmittance		
		Since 01.01.2014	Since 01.01.2017	Since 01.01.2021
1	Exterior walls with the temp. >16°C	0.25	0.23	0.20
2	Roofs, flat roofs, structural ceiling and no-heated attics: with the temp. >16°C	0.20	0.18	0.15
3	Ground floors	0.30	0.30	0.30

As a result of above changes new technological solutions appear but in the same time the precision of details becomes more and more important. Producers of different systems provide catalogues with construction and material solutions of the details appearing in specific systems.

## 2. The aim of the research

The aim of this paper is analysis of thermal parameters of different connection details of framework and massive wood systems. The analysis was conducted within the Therm 6.3 software.

THERM's two-dimensional conduction heat-transfer analysis is based on the finite-element method, which can model the complicated geometries of building product 3. Thermal analysis of chosen structural nodes for framework walls See Components for more details.

As far as the present framework structures are concerned, their thermal insulation is installed in a few layers to minimize failures of structural elements. Different framework system nodes (connections) were analyzed as an example.

## 3. Thermal analysis of selected nodes of stud wall construction.

For the section presented in the Ill. 1, the total thickness of thermal insulation of about 26 cm, allows to achieve the thermal transmittance  $U = 0.149$  (W/m<sup>2</sup>K). Such a level of insulation meets the requirements created by the NFOS for low-energy buildings NF40 (Table 1) located in I, II and III climatic zones of Poland.

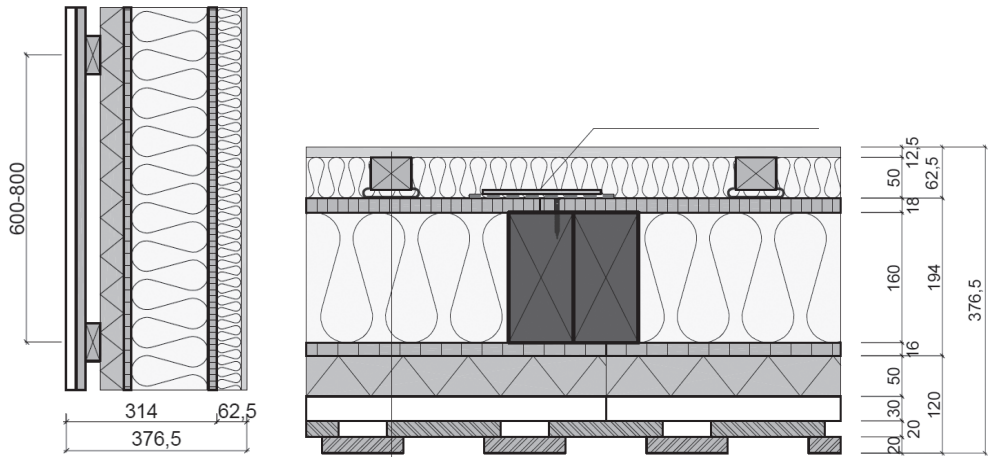

III. 1. Exemplary sections of framework exterior wall. Layers from inside: plasterboard 12,5 mm, mineral wool 50 mm, wood-based material 18 mm, mineral wool 160 mm, wood-based material 16 mm, wood lightweight board 50 mm

The requirements for roofs and flat roofs are much more demanding. The solution presented in III. 2 meets those requirements as  $U = 0,109$  ( $\text{W}/\text{m}^2\text{K}$ ).

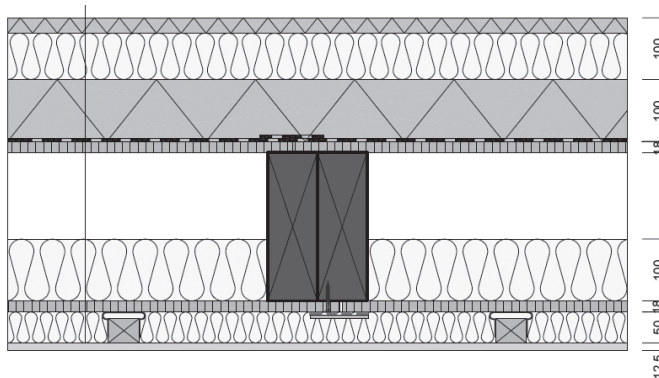

III. 2. Flat roof cross section  $U = 0,109$  ( $\text{W}/\text{m}^2\text{K}$ ) [2]

The solutions of the corner detail in framework technology, presented in the III. 3a, allow to keep high temperature on the inside surface of the wall. According to the results of the computer simulation presented in the III. 3b, for the interior air temp.  $-5^{\circ}\text{C}$ , the internal surface temperature in the corner is  $18,3^{\circ}\text{C}$ , which prevents water vapour condensation and the risk of mould growth.

Examples of different solutions, also correct as far as thermal issues, confirmed by the results of the calculations conducted in the THERM software, are presented in III. 4b, 5b and 5c.

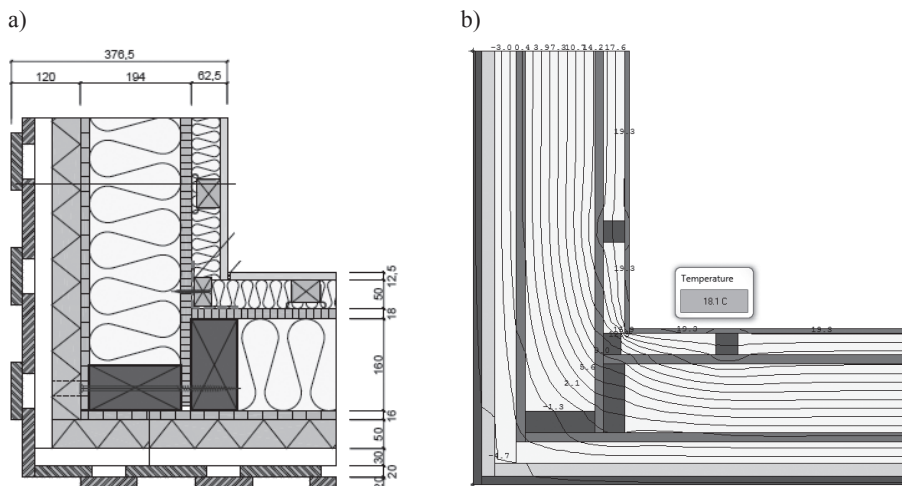

III. 3. a) Corner detail in the framework system (2), b) Isotherm layout in the analyzed node generated in the Therm

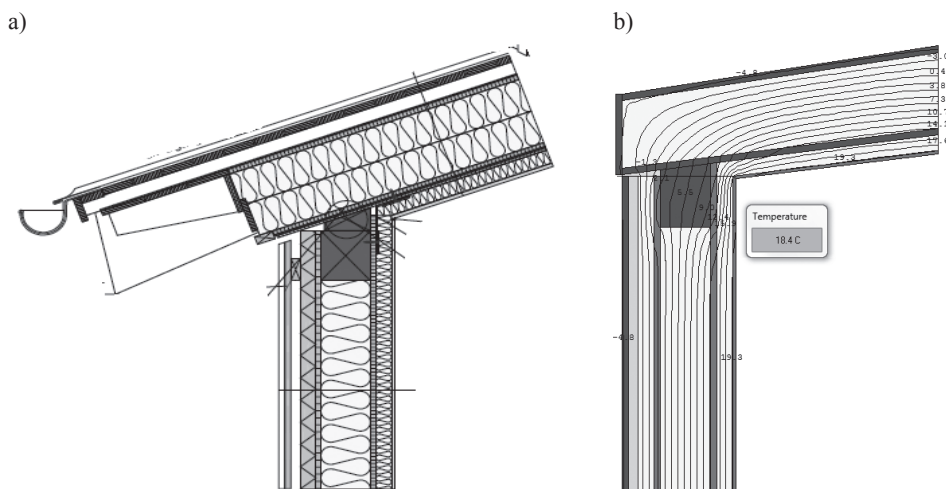

III. 4. a) Connection between external wall and roof, b) Layout of isotherm in the analyzed node generated in the THERM software

In the designing process of low-energy buildings, it is essential to carefully plan all architectural and construction details to minimize thermal bridge effects. Inevitable are the connections between the window and door frames and supporting walls. Some solutions of those bridges are presented in III. 6a and 7a. On the basis of computer analysis, the linear thermal transmittance values were determined. For connections of window sill, jamb and lintels, the linear thermal transmittance is  $0.071(\text{W/mK})$ .



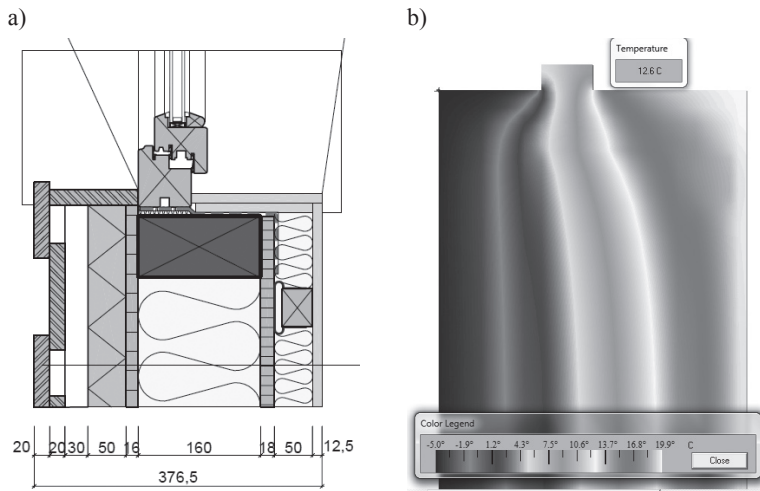

III. 7. a) Connection detail of window sill and external wall b) Temperature distribution in the node – the Thermo software

Presented solutions allow for the meeting of the requirements for low-energy buildings NF40. To meet the requirements of passive buildings, details of window and door carpentry must be characterized by higher insulation level.

#### 4. Thermal analysis of chosen construction details for massive walls

The authors have conducted an analysis, similar to that presented in chapter 3, for wooden walls in massive technology.

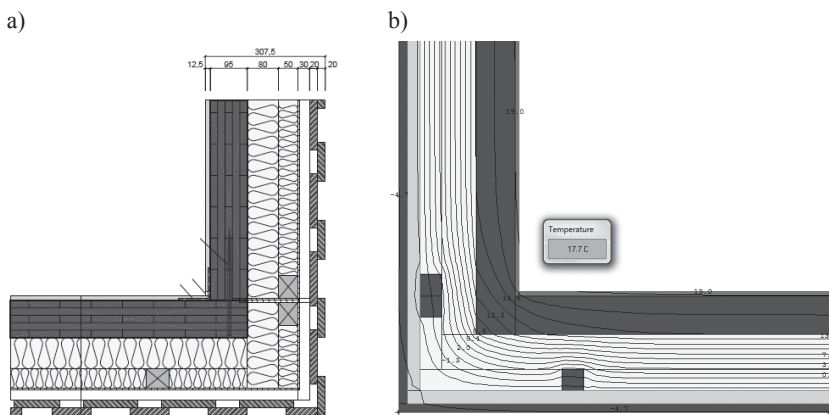

III. 8. a) Corner node solution e.g., in the CLT system (2), b) Layout of isotherms in the corner node – the THERM software

The solutions presented in the Ill. 8 and 9 allow, similarly to the framework system, to avoid surface condensation and the risk of mould growth.

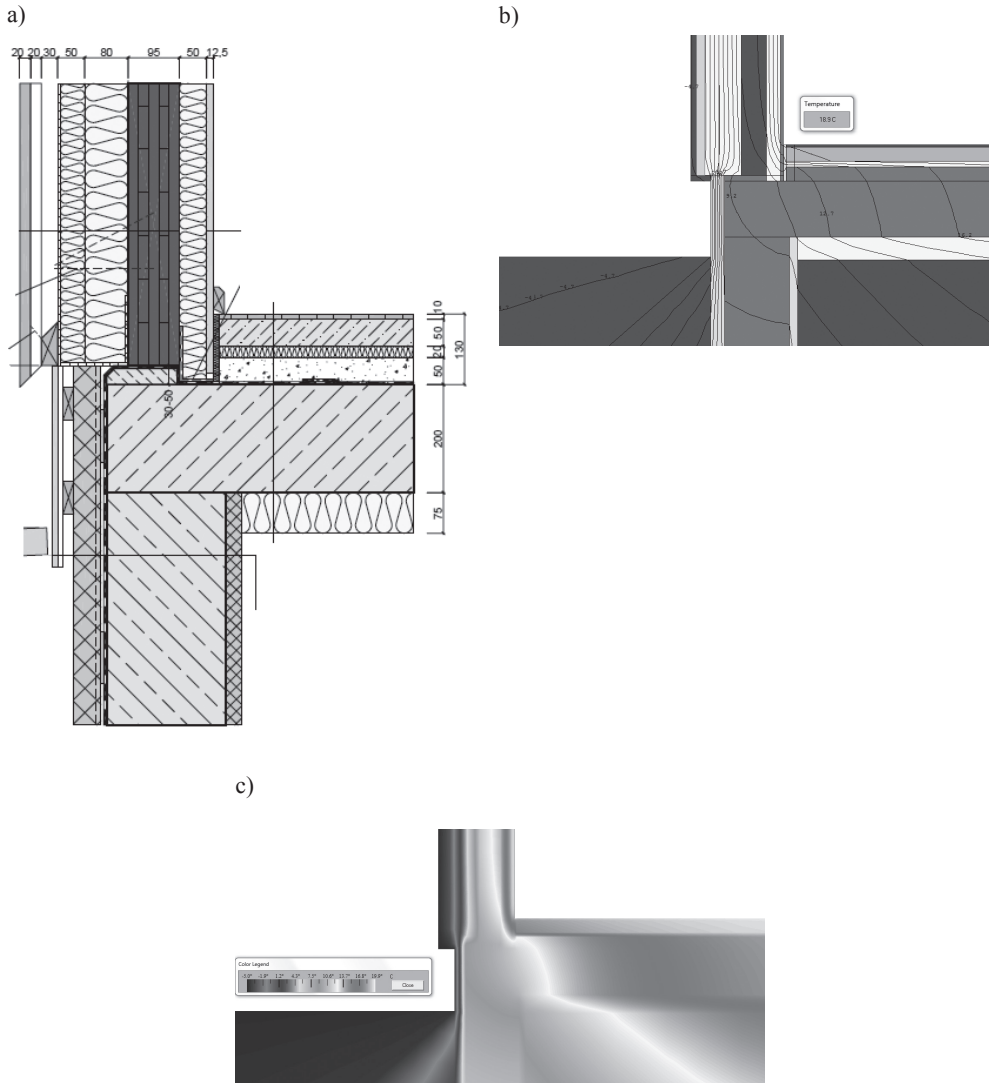

Ill. 9. a) Connection detail between ground floor and external wall, b) Isotherm layout in the node – the Therm software, c) Temperature distribution in the analyzed node – the THERM software

The linear thermal transmittance, for the detail shown in Ill. 10, is 0.084 (W/mK) and for the window sill equals 0.058 (W/mK).



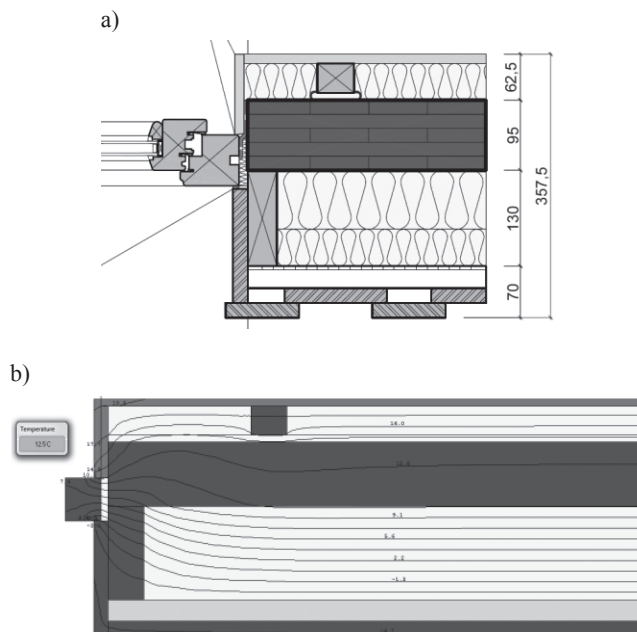

III. 10. a) Connection detail of window sill and external wall, b) Isotherm layout in the node – the Therm software

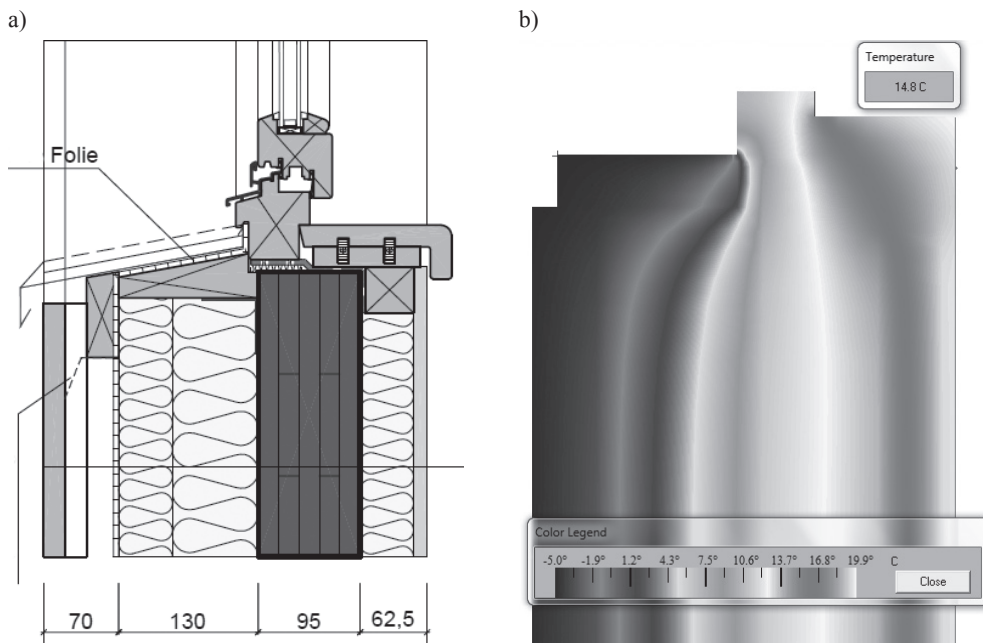

III. 11. a) Connection detail of window jamb and external wall, b) Temperature fields in the node

## 5. Conclusions

The analyzed examples allow to formulate a thesis about wooden architecture, which follows the latest trends and allows to reach low-energy building standards: “To comply with the standards of passive architecture, it is necessary to improve detail solutions, especially the connections between the window and door framings as well as supporting components”.

Table 3

### Chosen bridges complication

Technology	Solution type	Linear thermal transmittance
MBD	Window joinery in the windowsill	0.058 (W/mK)
SBD	Window joinery in the frame (windowsill, lintel)	0.071 (W/mK)
SBD	Window position in the frame	0.084 (W/mK)
MBD	Window position	0.084 (W/mK)

*Article was prepared as part of work L-1/116/DS/2013.*

## References

- [1] Kram D., Nowak K., *Modern technological and material solutions in the wood-based building constructions; X International Science and Technology Conference*, New building Technologies and Architectural Design, NBTAD 2013.
- [2] Leitdetails – Holzwohnbau TUG 2003; <http://www.proholz-stmk.at>; access: 15.09.2013.
- [3] PN EN ISO 10211:2008, Thermal bridges in building construction — Heat flows and surface temperatures — Detailed calculations.

KATARZYNA NOWAK, ANNA ZASTAWNA-RUMIN\*

## EXAMINATION OF A WALL BARRIER CONTAINING PHASE CHANGE MATERIAL IN A CLIMATE CHAMBER

### BADANIE PRZEGRODY ZAWIERAJĄCEJ MATERIAŁ FAZOWO-ZMIENNY W KOMORZE KLIMATYCZNEJ

#### Abstract

This paper presents the results of the experimental tests of components containing alternating phase material. The measurements of a light frame wall, in two options: plate with internal drywall filling and plate containing phase variable material, were conducted in a climatic chamber. The temperature and heat flux density distribution on the surface of plates for non-stationary temperature conditions in a climatic chamber were analyzed. The research stand simulated the conditions where the cladding plates were heated with the increase of internal air temperature rather than through direct heating. The main goal of the experiment was to check the utility of the test procedure and the measurement equipment to the planned research of building components containing PCM.

*Keywords: phase change material, PCM, heat capacity*

#### Streszczenie

W artykule przedstawiono wyniki badań eksperymentalnych przegrody zawierającej warstwę z dodatkiem materiału fazowo-zmiennego. Badania wykonano w komorze klimatycznej dla lekkiej ściany szkieletowej w dwóch wariantach: z okładziną wewnętrzną wykonaną z płyty gipsowo-kartonowej oraz płyty zawierającej materiał fazowo zmienny. Przeprowadzono pomiary przebiegu temperatury oraz rozkładu gęstości strumieni ciepłych na powierzchniach płyt dla niestacjonarnych warunków panujących w komorze klimatycznej. Przygotowano stanowisko badawcze, w którym nagrzewanie płyt okładzinowych następowało poprzez wzrost temperatury powietrza w pomieszczeniu a nie poprzez ich bezpośrednie nagrzewanie. Za główny cel eksperymentu przyjęto sprawdzenie przydatności procedury badania oraz użytej aparatury do planowanych badań elementów budowlanych zawierających PCM.

*Słowa kluczowe: pojemność cieplna, PCM, pojemność cieplna, akumulacja cieplna*

\* Ph.D. Katarzyna Nowak, M.Sc. Anna Zastawna-Rumin, Institute of Building Materials and Structures, Faculty of Civil Engineering, Cracow University of Technology.

## 1. Introduction

One of the not too many disadvantages of a light-frame construction is a problem with too low heat stability of wall barriers. Its capacity results in deficiency of heat stability that causes seasonal overheating of a building and large temperature oscillations of internal air during temperature changes of external air. It influences thermal comfort and determines the destination of a building. Overheating of a building results from solar radiation passing through glass surfaces to wall barrier surfaces inside a building. Absorption and accumulation of shortwave radiation and then secondary emission of longwave radiation takes place on wall barrier surfaces. The processes cause increase of surface temperature of wall barriers and significant increase of air temperature in a building. The consequence of the processes is the increase of so called “operative temperature” in premises that have adverse effects on thermal comfort. The referenced reasons prove the significance of the heat capacity of wall barriers. The idea of using phase change materials to increase heat capacity of materials is built on the energy saving process such as latent heat of phase change. Accumulation or emission of large amount of heat occurs during phase transition and is accompanied with a small temperature change of a specific PCM. The aim of PCM application in building components is to significantly increase the heat capacity of a building without changing its low construction weight.

## 2. The aim

The object of investigation is a wall barrier containing a phase change material layer. The aim is to determine the usefulness of the examination procedure and applied apparatus for evaluating the influence of PCM on thermal parameters of an internal microclimate. The study was a validation test confirming the efficiency of the applied examination procedure necessary for further studies on PCM.

## 3. Description of a measuring position

A measuring position was built in units of chambers. It consisted of two chambers (called: hot and cold chambers) connected by the investigated wall barrier (Ill. 1). The chambers were equipped with heating, cooling and ventilation units with automatic controls which allowed to keep specific temperatures in both chambers. There was also a possibility to control and regulate heat and humidity changes according to scheme.

The investigated wall barrier was made of a light structure and consisted of a wooden grid filled with a 15 cm layer of mineral wool. The finishing layer situated in a hot chamber consisted of a plaster board. There were also two 1 m<sup>2</sup> boards fixed abreast to a finishing layer: an ordinary plaster board and a board with the addition of phase change material, BASF brand – SmartBoard 26 (Ill. 2). Organic material used in the PCM board was Micronal; its melting point equals 26°C and a heat of phase transition equals 110 kJ/kg (according to manufacturer data). 30% of the board mass fraction consisted of PCM. Both boards had similar densities and thermal conductivities. Parallel board placement ensured identical external conditions during measurements and allowed direct comparison of the measured parameters.

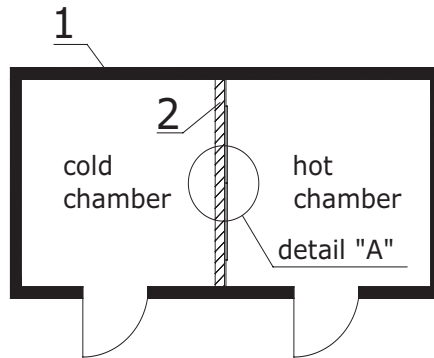

Ill. 1. Scheme of climate chambers: 1 – chamber envelope with 15 cm of polyurethane 2 – test component

## detail "A"

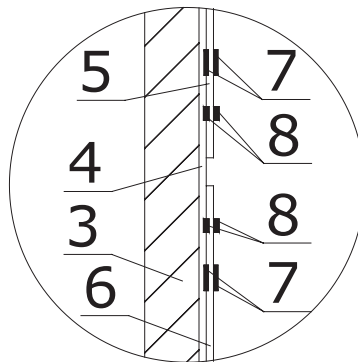

Ill. 2. Detail of the test (building component): 3 – light wood frame component filled with 15 cm of mineral wool, 4 – plaster – cardboard, 5 – plaster – cardboard, 6 – plaster – cardboard with the addition of PCM (SmartBoard 26), 7 – heat meters, 8 – transmitters Pt – 1000

### 4. Measurement equipment

Temperature and heat flux were the parameters measured both at the surface and between layers of a wall barrier. 4 sensors Pt 1000 and 2 heat meters (The first one round with a radius of 33 cm and the second one rectangular with dimensions of 120 cm × 120 cm) were placed at the surface of each board (Ill. 3, 4). Four temperature sensors Pt 1000 and one circular heat meter were also placed below the surface of each board (Ill. 5, 6). Air temperature inside the chambers was measured by temperature sensors Pt 100 and Pt 1000. Measured parameters were recorded by a data collecting system: Ahlborn Almejo and connected with a computer. All measurement data were collected using system Data-Control 4.2. Further calculations were conducted on Microsoft Excel.

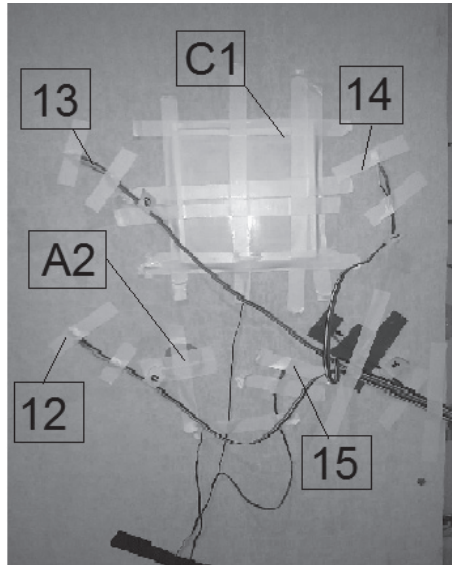

III. 3. Picture of the plate with sensors attached at the surface. 12, 13, 14, 15 – Pt 1000 temperature sensors, A2 – circular heat meter 33 mm dia, C1 – square heat meter 120 × 120 mm

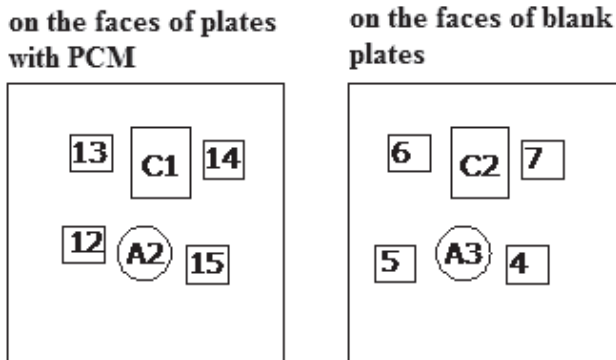

III. 4. Location of sensors on the plate surface. 4, 5, 6, 7, 12, 13, 14, 15 – Pt 1000 temperature sensors, A2, A3 – circular heat meter 33mm dia, C1, C2 – square heat meter 120 × 120 mm

### 5. Study in a climate chamber

The article presents the results of one out of three study stages. The study was conducted in 24-hour cycles allowing examination of real temperature changes in sunny premises. Steady operating conditions were kept in a hot chamber during a whole cycle of examination. Air temperature was constant and equal to 18°C. In a cold chamber, temperature varied cyclically. There was an increase of air temperature from 18°C to 36°C and then a decrease to

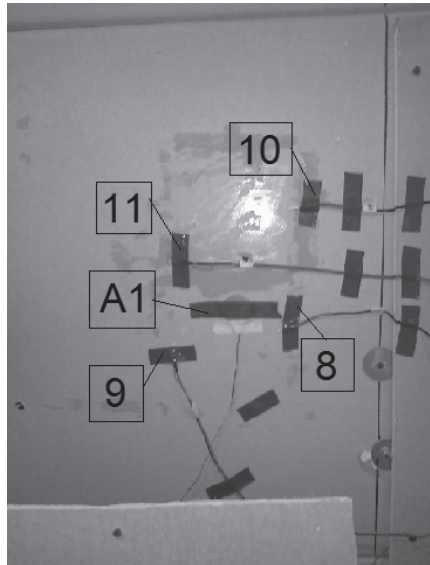

III. 5. Picture of the PCM plates with sensors located below the plate surface. 8, 9, 10, 11 – Pt 1000 temperature sensors, A1 – circular heat meter 33 mm dia

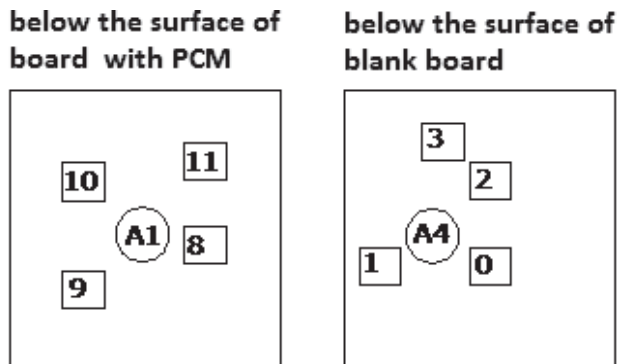

III. 6. Placement of sensors below the plates' surface. 0, 1, 2, 3, 8, 9, 10, 11 – Pt 1000 temperature sensors, A1, A4 – circular heat meter 33 mm dia

starting values during 12 hours. Both plaster boards underwent the same operating conditions during measurements.

This study stage was to observe the temperature changes on the surfaces of front and back boards in a situation when on one side of a wall barrier the temperature varies. This article presents the results of a study stage with a temperature observed during sunny days of springtime in our climate.

Air temperature in a chamber increased 6 degrees every hour because of the technical capacity of the control equipment. The rate of temperature change was not constant; it



changed according to the scheme presented in Ill. 7. The scheme presents three repeated cycles of temperature distribution.

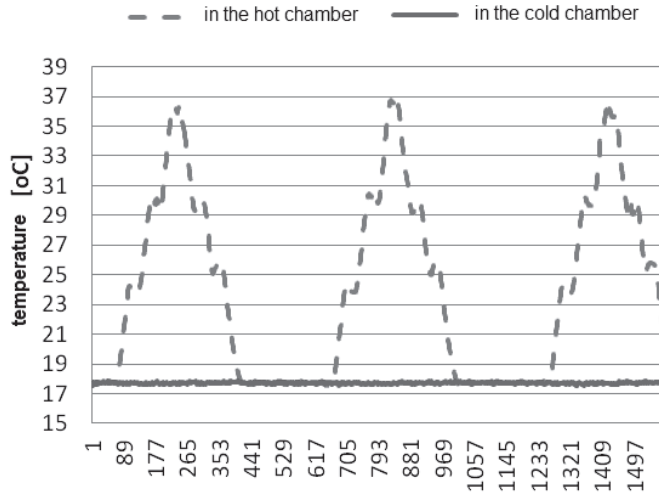

Ill. 7. Measurement of the air temperature distribution in the hot and cold chamber during testing

The difference between internal air temperature and temperature of finishing surfaces is the information on the significant value of thermal comfort from the premises point of view. The chart presented in Ill. 8, allows to observe temperature changes that occurred on front board surfaces of an ordinary plaster board and a board with the addition of phase change

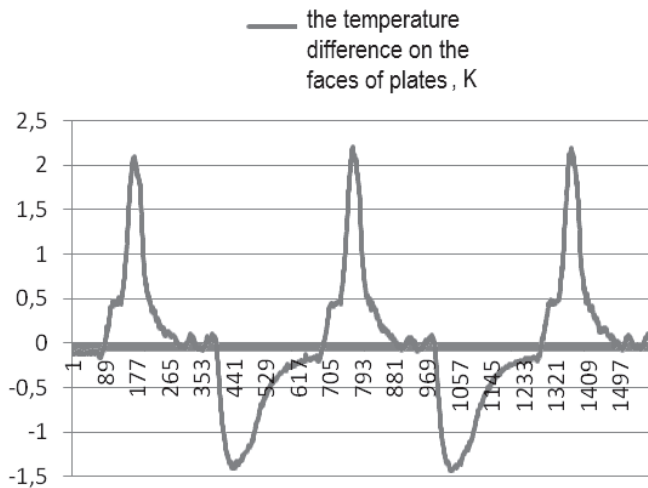

Ill. 8. Measurement of the temperature difference on the faces of blank plates and plates with PCM

material. During the process of air temperature increase, the temperature on the surface of a board containing PCM was lower max.  $2.2^{\circ}\text{C}$  than on the surface of an ordinary board. Such advantageous temperature change of a board containing PCM results from the higher possibility of heat excess accumulation in the material. During the study the results were recorded every 2 minutes (see charts presented in the article).

There are few significant relations observed after the analysis of temperature distribution on both board' surfaces depending on air temperature changes (Ill. 9). When surrounding temperature increases, advantageous influence of PCM with a delay in increase of surface temperature can be observed in the air temperature range between  $22^{\circ}\text{C}$  to  $30^{\circ}\text{C}$ . When the air temperature exceeds  $30^{\circ}\text{C}$ , surface temperature on both boards equalises. It results from the phase change temperature of Micronal which equaled  $26^{\circ}\text{C}$ .

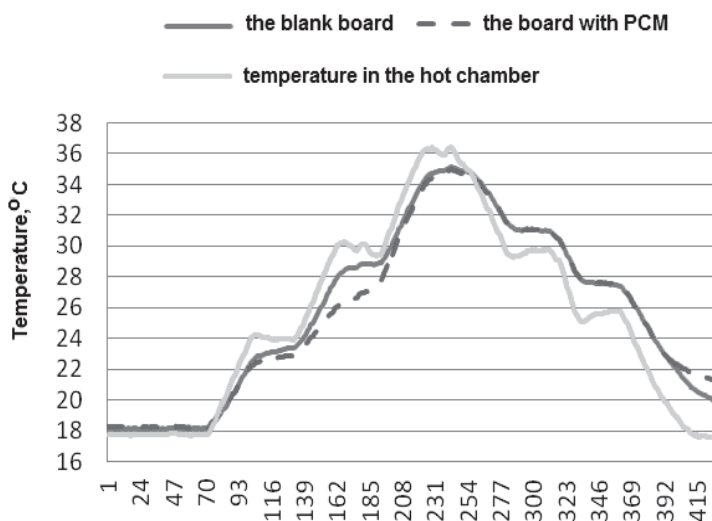

Ill. 9. Measurement of the air temperature distribution in the hot chamber and temperature measurement on the front surface of tested boards

Important aspects related to the possibility of energy storing in a PCM was a measure of temperature difference that occurred in a specific moment between front and back surfaces of both types of boards.

It can be observed that during an air temperature heating cycle in a chamber, the value of surface temperature behind a board with PCM is lower than behind an ordinary board. It results from the absorption of thermal flux by a phase change material and much slower rate of reaching the surface of a back board.

Ill. 11 presents the change in density of thermal flux absorbed and emitted on the front surfaces of both boards. The chart presents explicitly much higher heat absorption for a board containing PCM. The results of integration of thermal flux density for examined conditions absorbed by both types of boards in studied time intervals indicate 45% higher possibility of heat accumulation by a board with PCM.

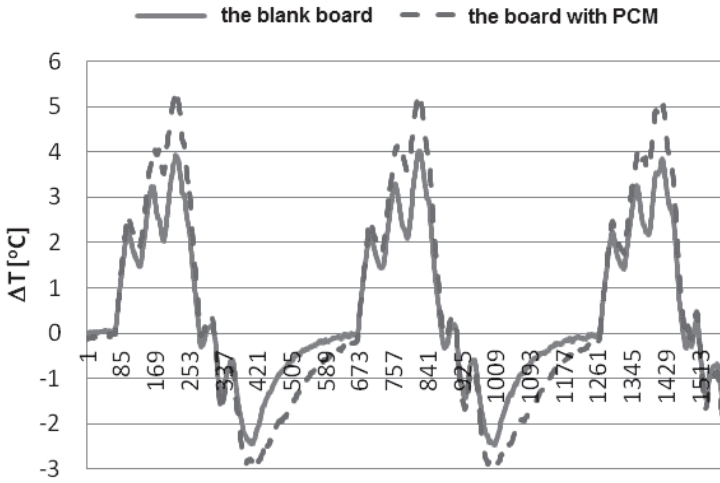

III. 10. Temperature differences between the values on the face and back of both tested boards

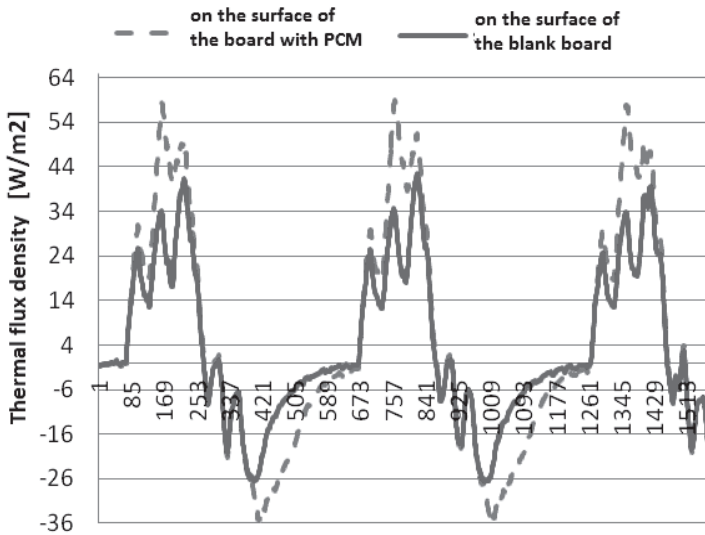

III. 11. Thermal flux density measurement of the end faces of gypsum boards

Thermal conductivity was examined for both plaster boards used in the study. Obtained  $\lambda$  values for both materials were comparable [6]. Differences in density of materials and their thickness can be considered as insignificantly small. From the results presented in the article, it can be concluded with some certainty that the temperature differences and density of thermal flux differences between a board containing PCM and an ordinary plaster board result only from accumulative properties of phase change material and not from differences between thermal flux passing through the boards.

## 6. Results

Obtained results of integration of thermal flux density for examined conditions absorbed by both types of boards in studied time intervals indicate a 45% higher possibility of heat accumulation by a board with PCM. It demonstrates the possibility of an increase of thermal capacity of the premises simultaneously with the application of the same amount of finishing material, but with the addition of PCM. Obtaining higher thermal capacity involves a decrease of maximal temperature on a wall barrier surface and also involves higher costs due to actual material prices.

In the case of directly insulated wall barriers, the efficiency of the applied material will be higher. Such an effect will result from the increase of heat exchange in the form of radiation. A solution of such type can change the thermal characteristics of a premises in a significant and advantageous manner (in the case of light structure buildings).

## References

- [1] Wnuk R., Jaworski M., *Badania charakterystyk cieplnych elementów budowlanych akumulujących ciepło zawierających materiały PCM (Phase Change Materials)*, Polska Energetyka Słoneczna 2, 4/2010, 1/2011, 5-11.
- [2] Wnuk R., *Magazynowanie ciepła, pozyskanego z energii promieniowania słonecznego, z wykorzystaniem materiałów fazowo-zmiennych, w budownictwie*, II Konferencja SOLINA 2008, Innowacyjne Rozwiązania Materiały i Technologie dla Budownictwa.
- [3] Soares N., Costab J.J., Gasparb A.R., Santosc P., *Review of passive PCM latent heat thermal energy storage systems towards buildings' energy efficiency*, Energy and Buildings 59, 2013, 82-103.
- [4] Wnuk R., *Bilans energetyczny pomieszczenia ze strukturalnym, funkcjonującym w cyklu dobowym, magazynem ciepła z materiałem fazowo-zmiennym*, Czasopismo Techniczne, 1-B/2009, 269-277.
- [5] Berrouga F., Lakhala E.K., Omania M. El, Faraji M., Qarniac H. El, *Thermal performance of a greenhouse with a phase change material north wall*, Energy and Buildings 43, 2011, 3027-3035.
- [6] Nowak K., Zastawna-Rumin A., *Badanie i analiza przegrody z dodatkiem materiałów fazowo-zmiennych w warunkach niestacjonarnych*, Fizyka Budowli w Teorii i Praktyce, 2013, 291-296.



BOŻENA ORLIK-KOŹDOŃ\*, MICHAŁ WŁODARCZYK\*\*, TOMASZ STEIDL\*

## INTERNAL THERMAL INSULATION IN THE TECHNICAL AND ARCHITECTURAL ASPECT

---

## CIEPLNE IZOLACJE WEWNĘTRZNE W ASPEKCIE TECHNICZNYM I ARCHITEKTONICZNYM

### Abstract

The paper presents the possibility of applying the internal systems of thermal insulation of heated rooms with design guidelines. It discusses the problems of the inner insulation effect, the re-use and new aesthetics on comfort room thermo-humidistat.

*Keywords: new technologies in construction, passive houses, thermal insulation, aesthetics of buildings, modernization and adaptation*

### Streszczenie

W artykule przybliżono możliwości zastosowania systemów dodatkowej wewnętrznej izolacji cieplnej pomieszczeń ogrzewanych wraz z wytycznymi projektowymi. Omówiono problematykę wpływu tejże izolacji przy zmianie sposobu użytkowania i estetyki na komfort cieplny pomieszczeń

*Słowa kluczowe: okładziny z kamienia naturalnego, transport wilgoci*

---

\* Ph.D. Eng. Bożena Orlik-Koźdoń, Ph.D. Eng. Tomasz Steidl, Faculty of Civil Engineering, Silesian University of Technology.

\*\* Ph.D. Eng. Arch. Michał Włodarczyk, EUROARTIS.

## 1. Introduction

Increasingly more often we are witnesses of changes in the structure and esthetics of the objects connected with re-use, adaptation and the varying market needs for spaces fulfilling the assumed standards of use. Particular care for the structure and the kind of technology necessary for additional thermal insulation is required by the adaptation of monuments as well as the ones protected monumentally (conservation). In these cases the change of functions often demands such interventions. Designing these kind of arrangements is quite complicated. The problems are thermal bridges, materials used, dysfunctions of the flow of water vapour through the external wall, as well as lack of ventilation. These problems, considering the negative scenario, may cause the lack of assumed results or even a worsening of the exploitation of rooms. During the making of the project on the expected thermal insulation inside a building, an important role is played by integrated designing with the participation of architects and civil engineers in order to exclude any disadvantageous effects. These negative effects may be related to internal thermo-modernization, use of modern technologies and applying the potential of architecture for achieving the effect of low-energy and energy-safe features.

## 2. Applied material and technology solutions

Among the material solutions now used, we may choose traditional ones, which follow the use of classic thermo-insulating materials or on the contrary, solutions based on modern thermal materials.

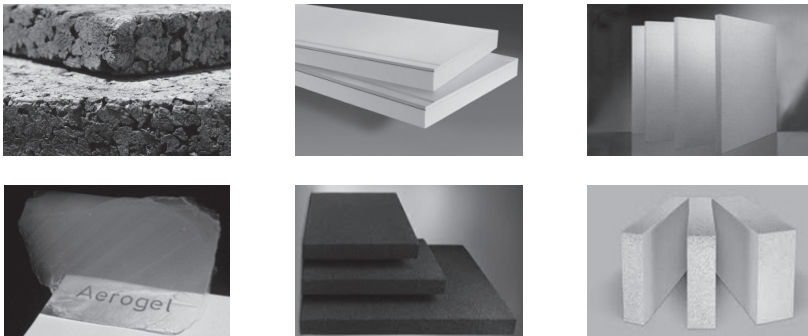

Ill. 1. The modern thermo-insulating materials: 1) cork-plates, 2) polyurethane plates, 3) climate plates, 4) aerogel, 5) foamglass, 6) hydroactive plates [8, 10]

The traditional technologies used in these solutions are among others styrofoam and glass wool, rock or wood; they may be set on the grate and finished with g-k plates or finished as in the ETICS method. The insulation with mineral wool is hermetically covered with a layer of efficient vapour-insulation.



Within the solutions with modern materials applied, two methods may be distinguished [8]:

- The needx of thermo-insulation with a hermetical vapour-insulating barrier from inside of the building.
- Systems which guarantee the free flow of a diffusion stream through the external wall.

The systems with vapour-insulation from the inside of the building are working best in objects with a high level of humidity. In connection with the total denial of diffusion of the water vapour through the surface, the highest effectiveness of the ventilating installation should be ensured.

The systems, which guarantee the free flow of the diffusion stream, demand a high vapour-permeability of all of the external wall layers. In the case of living apartments or rooms destined for the long-term stay of people, the natural humidity regulation of interiors resulting in the free flow of vapour through the thermal insulation layers is the more profitable solution than the thermal insulation with vapour-insulation.

Table 1

**The internal thermal-insulation of walls – material and technology solutions**

	Insulating material	Installation on walls	Finishing of the inner surface
Thermal insulation with small diffusion resistance, lack of possibility of humidity diffusion	Mineral wool + vapour insulation	Wooden grate or aluminium profile	Thin-layer plaster (ETICS), Gypsum-cartoon plates
Thermal insulation with large diffusion resistance, lack of possibility of humidity diffusion	XPS, EPS+vapour insulation, Foamy glass, Polyurethane plates	Steel-profiles-grate, areally bonded (glued with the total surface) with the basis or the strand-point method	System spatula, Thin-layer plaster, Ceramic plates, Insulating wall-paper
Thermal insulation with small diffusion resistance, with possibility of humidity diffusion	Climatic plates, Hydroactive plates	Areally bonded (glued with the total surface)	Thin-layer plaster (system ETICS), System spatula

### 3. Designing of additional thermal insulation from inside

According to the legal requirements [1], on the inner surface of the external wall the condensation of water vapour, which enables the development of mould is not allowed. In order to keep this condition, in reference to the external walls and their construction junction, they shall be described by the temperature coefficient  $f_{Rsi}$  of a value, which is not lower than the demanded critical value. We can select it depending on the norm PN-EN ISO 13788 [2] referring to the method of counting the temperature of the internal surface necessary for avoiding the critical humidity of the surface and in-between-layer condensation [2].

The given method does not include many physical phenomena occurring in the layers of building walls. The other inconvenience is the accepted classification of internal air humidity based on the data created according to the buildings in Western Europe. In the standard [2] attachment A, the application of the local measuring-values for other climatic zones without delivering the land reference values, is permitted. We may assume that the Polish conditions of apartments' exploitation are in majority similar to the conditions in other countries, which does not mean that in the calculations we shall always take the given classification.

The Norm [2] is questionable as far as the quality of obtained results of calculations and the way of its interpretation is concerned. In spite of such doubts, this standard is the base for making the majority of thermal and humidity calculations in order to apply it to the projects in Polish conditions.

The recommended methods of calculations according to the Polish Norm PN EN ISO 13788 are matched to the typical building of the external wall. The terms are not strictly precise for carrying on the calculations serving the estimation of the thermal and humidity conditions of the external wall by the untypical design solution, which is additional thermal insulation from the inside of the existing wall.

The authors suggest the following evaluation methodology of the possibility of necessary thermal insulation from the inner side because of the probability of humidity and mould based on personal experiences and analysis of literature [4, 5, 7]:

- Recognition of the material structure of the external wall along with making the outcrops and measuring the thickness of the existing layers.
- Measuring the surface humidity by means of non-invasive methods. Near ceramic walls thicker than 51 cm, a humidity analysis of the samples taken from the outcrop is necessary.
- Finding the kind of material of the external wall layers and matching the physical specifics using the accessible data [3, 6]. In the walls of monuments, the research on the wall properties, also recommend vapour-permeability of the ceramic material.
- Making an inventory of sensitive places: linear thermal bridges.
- An obligatory step is the calculation of the  $f_{Rsi}$  value in all of the connecting places of the thermally insulated external wall along with the close-fitting walls.
- The choice of material and technology of thermal insulation.
- Arranging a functional programme of the room, describing the possibility of ensuring the temperature and inner air humidity regulation, or assigning the exploitative air humidity, which must not be exceeded because of the condition  $M \leq 0$ , where  $M$  – [kG/m<sup>2</sup>a], a calculative amount of condensate for the conditions of the external climate according to the nearest meteorological station. Important is the rule of making the calculations for three average month values of the outer air temperature from the meteorological database, which is:  $t_{sr}, t_{max}$  i  $t_{min}$ .
- Calculation of the temperature at the point of junction of the layers: the existing external wall – the material of thermal insulation, considering the bidimensional thermal flow.
- The choice of thickness of the additional thermal insulation referring to the condition  $M_{min}$ , where  $M$  is the total calculative amount of the condensate [kg/m<sup>2</sup>a], counted according to [2]; the method of surface finishing including the painting cover, shall be taken into account during evaluation.

In all of the estimations carried on considering [2], it is advisable to exclude the counting of internal humidity, depending on external conditions. Apart from this, personal characteristics of the inner microclimate are applied and backed up with experience or with a survey.

Moreover, as the last stage of the design, is to foresee the use of the warming-up method „IN” [9], for places particularly exposed to condensation. In these endangered places, as the survey shows, the value  $f_{Rsi} < f_{Rsimax}$ , is to be kept along with the assurance of a large diffusional resistance of the exterior layer in new-designed thermal insulation. A large diffusional resistance may be guaranteed by applying the appropriate foil or x sets of paintx covers matching the type of inner plaster.

#### 4. Example of designing the additional thermal insulation from inside

The example for analysis, is the typical brick wall 38 cm thick, together with the plaster. In the first scenario (W\_1), the external wall has been insulated with a polyurethane plate 10 cm thick (the physical parameters of modern materials according to producer information). The interior has been finished with acrylic plaster. In the second scenario (W\_2) the thermal insulation has been made of a hydroactive plate with the same finishing thickness from the inside by the system spatula. The humidity of the wall has been measured resulting in  $w_{sr} = 3\%$ . The program worked out by the authors allows for taking under consideration the material's initial humidity. In the work, only the differences in humidity growth were shown. The material data has been set based on [4]. The living conditions of the room have been arranged as for normal conditions, which means  $t_i = 20^\circ\text{C}$ ,  $\varphi_i = 50\%$  for all the months in a year. The building is located near to the meteorological station of Katowice. Relating to [2], the calculations of increasing the humidity in the brick wall have been made assuming that one condensation zone may appear. According to the calculation results, the vaporization of the whole condensation in the summer months is foreseen.

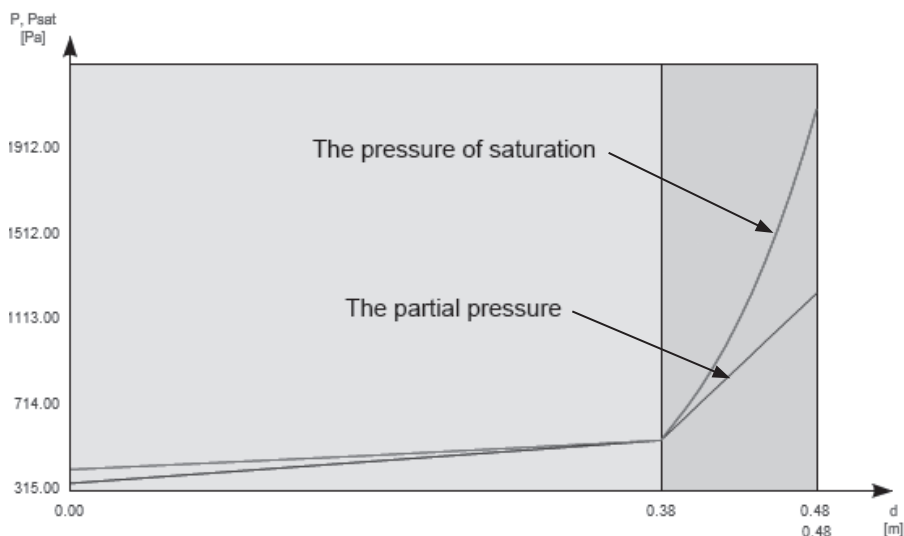

III. 2. Diagram example of diffusion for the external wall in the scenario W\_1. The external boundary conditions assumed for the coldest month of the year, which is in February (average values). The schedule of the pressure in the external wall

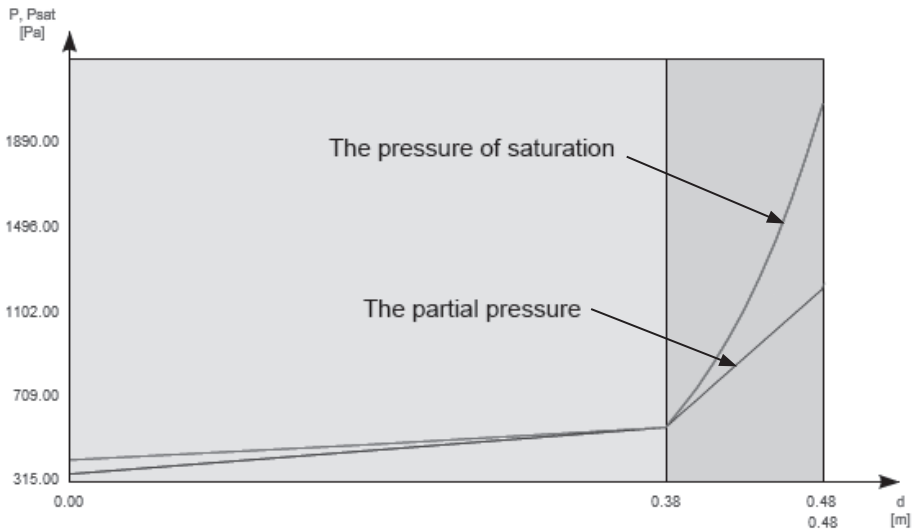

III. 3. Diagram example of diffusion for the external wall built in the scenario W\_2. The external boundary conditions assumed for the coldest month of the year, which is February (average values)

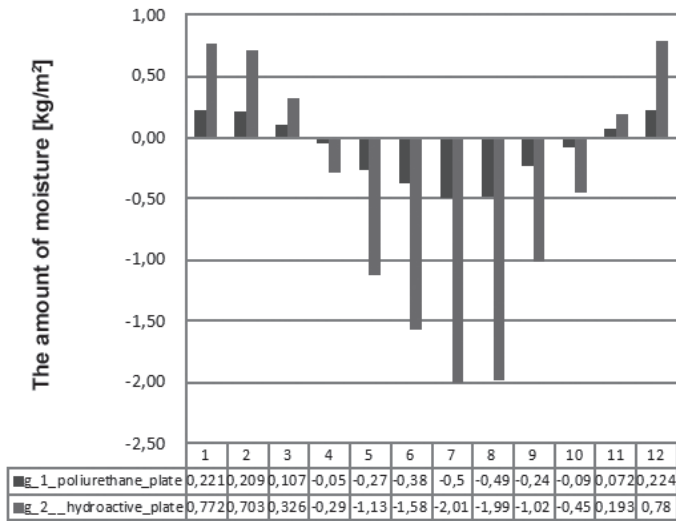

III. 4. Humidity accumulation in the external wall layer for the scenario W\_1 and W\_2. External boundary conditions – meteorological station in Katowice (average values)

The linear bridges have been inventoried, along the connections with ceilings and walls dividing the thermally insulated room from other rooms. The appropriate calculations have been made for such a bridge using the programme Therm 7. The calculations were made for internal temperature: 20°C and external temperature accepted for the coldest temperature in Katowice weather station, i.e., -2,4°C.

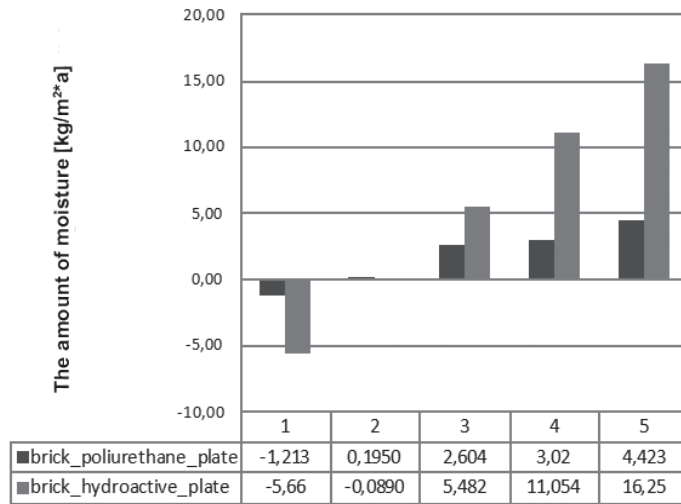

III. 5. Setting up of the amount of the condensate  $M$  [kg/m<sup>2</sup>] by the changing living-conditions: humidity  $\varphi_1 - 50\%$ ;  $\varphi_2 - 60\%$ ;  $\varphi_3 - 70\%$ ;  $\varphi_4 - 80\%$ ;  $\varphi_5 - 90\%$  by the constant temperature  $t_i = 20^\circ\text{C}$

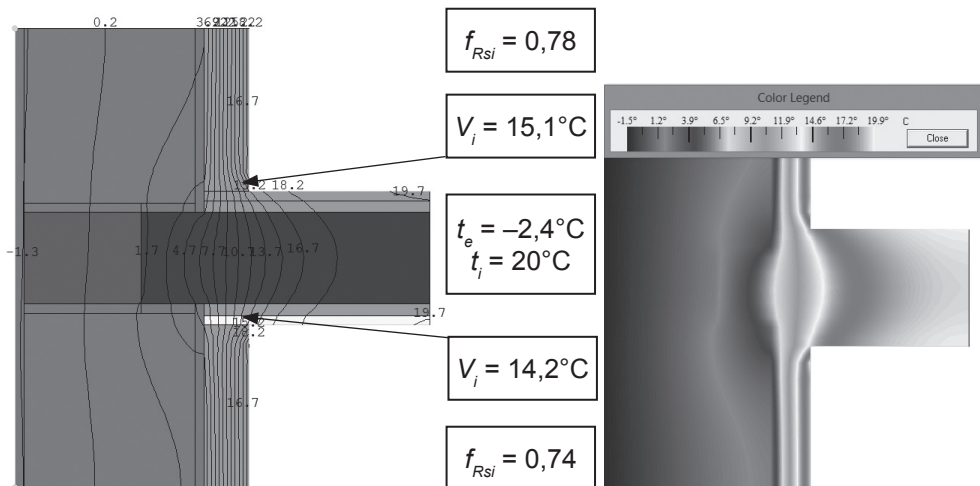

III. 6. Example of calculations of surface condensation in the thermal bridge in the case of the inner thermal insulation: beam of wooden ceiling in the brick wall W\_1. Calculations, programme Therm 7. III. 8. Scheduling information – distribution of temperature area

From the analysis of the simulation results we can observe that in spite of the warming from the inside, the constructional part of the wall stays under the influence of the external environment's temperature. The reallocation of the negative temperature isotherms deep into the wall is a disadvantageous phenomenon not only for the inside of the wall, but also for the surface of contact of the internal plane with the new insulation, in other words, in the

adherent layer. At the unfavorable parameters of the internal environment's microclimate with negative external temperatures, the theoretical probability of steam condensation as well as other undesirable effects, including for instance mould, will occur exactly in this layer. For the examined case, the risk of occurrence of surface condensation was specified calculating the so-called temperature factor  $f_{Rsi}$  on the internal surface; this factor has a superior value than the critical value given in the technical specifications [1].

## 5. Conclusions

The method of thermal insulation of an external wall from inside of a building depends on a few factors: The assumed way of the room use, the kind of wall material, the kind of material used for additional thermal insulation as well as the technology of its fixing. Considering the vapour-permeability of such insulation is of much importance. The external walls thermally insulated on the inside are to be precisely analyzed. This analysis will take into account the influence of all the factors affecting the density and distribution of the penetrating diffusional stream of water vapour. The appropriate type of thermo-insulating material, the right thickness of its layer, the way of finishing of the interior surface of the wall and the remaining solutions of the insulation details including particularly meaningful thermal bridges, may be described based on the results of the analysis. The humidity condition of the external wall before insulating is the factor, which may in a significant way disturb the results obtained in the assumed calculation method. This status is to be described in the most possibly detailed way before making the calculation. The second element, which has an important impact on the effect correctness, is the foreseen way the room is used by the user [5]. This aspect shall be treated as the basic one, because it determines the actual state of the external wall's humidity.

The inner insulations are being applied mainly in the existing structures as additional thermal insulation from the inside of the external wall. Besides, very often it is a chance for saving the building by the process of re-use, returning it back to life. In these cases we refer to them as the processes of adaptation or revitalization. Its applicability may also be helpful in improving the acoustic character of a room, hiding a part of the installations or even fixing the heating elements in the finishing layer. In architectural objects under monumental protection, this way of insulating seems frequently to be the only possibility to warm them up. This is the economical and long-term process, keeping at the same time the historical appearance of a monument. Nevertheless, the methodology presented in the paper, which analysis the thermal modernization is necessary. On the one hand, it reduces the risk of the disturbance of the vapour-permeability of external walls and therefore the destruction of the walls in a building can be avoided in extreme cases. On the other hand, the decrease of the living surface is the inconvenience of such insulation. Though, this intervention allows to significantly increase the comfort of the use of a room and simultaneously to decrease the energy demand. Presently, this fact plays a major role and is of undeniable advantage to the directly affected inhabitants.

## References

- [1] Rozporządzenie Ministra Infrastruktury z dn. 12 kwietnia 2002 r. w sprawie warunków technicznych, jakim powinny odpowiadać budynki i ich usytuowanie (Dz. U. Nr 75, poz. 690), z późniejszymi zmianami.
- [2] PN-EN-ISO 13788:2003. Ciepłno-wilgotnościowe właściwości komponentów i materiałów budowlanych i elementów budynku – Temperatura powierzchni wewnętrznej dla uniknięcia krytycznej wilgotności i kondensacji międzywarstwowej – Metody obliczania.
- [3] PN-EN 12524:2002 Właściwości ciepłno-wilgotnościowe materiałów.
- [4] Kuenzel H.M., Kiessl K., *Calculation of Heat and Moisture Transfer in Exposed Building Components*, International Journal of Heat Mass Transfer, 40 (1), 1997, 159-167.
- [5] Krause P., Steidl T., Orlik B., *Renowacja ścian zewnętrznych w aspekcie izolacyjności termicznej*, Konferencja szkoleniowa: Renowacja Budynków i Konserwacja Zabytków, Warszawa 03.10.2012.
- [6] Pogorzelski J.A., *Fizyka Budowli część X. Wartości obliczeniowe właściwości fizycznych*, Materiały Budowlane, 3/2005, 79-81.
- [7] Pel L., Kopinga K., *Moisture transport in porous building materials*, Eindhoven University of Technology, 1995.
- [8] Steidl T., Orlik B., *Docieplanie przegród zewnętrznych od wewnątrz*, Materiały, technologie i projektowanie, IZOLACJE, 4/2013.
- [9] Wójcik R., *Docieplanie od wewnątrz*, Inżynier Budownictwa, Nr 04/2011 ([www.inzynierbudownictwa.pl/ocieplanie\\_od\\_wewnatrz](http://www.inzynierbudownictwa.pl/ocieplanie_od_wewnatrz), 4608).
- [10] Włodarczyk M., Steidl T., *Nowe termoizolacje w aspekcie technicznym i architektonicznym*, Czasopismo Techniczne, 2-A/1/2011.
- [11] Włodarczyk M., *Ściany zewnętrzne budynków w aspekcie zdrowia*, Konferencja „Architektura i technika a zdrowie”, materiały sympozjum w publikacji, Gliwice 2012.





MARCIN RADOŃ, GRZEGORZ NOWAK\*

## INNOVATIVE TIMBER CONSTRUCTION SYSTEMS IN TERMS OF DESIGN AND STRUCTURE PHYSICS SOLUTIONS

### INNOWACYJNE SYSTEMY BUDOWNICTWA DREWNIANEGO W ASPEKCIE ROZWIĄZAŃ KONSTRUKCYJNYCH I FIZYKI BUDOWLI

#### Abstract

This paper presents examples of modern timber building systems. The beginnings of the wooden structure systems of frame and massive structure as well as new solutions with reference to traditional ones are presented in the paper. Modern timber systems presented in the paper are selected in such a way as to show the diversity of their structure. Examples of systems based on logs, beams and plate (solid and boxes) elements are shown in the paper. Description of each system contains information about the basic elements of the structure, connection methods and materials used in their production. Degree of prefabrication and assembly methods are also discussed. Special attention is paid to the issues of the building physics of wooden partitions, thermal parameters and the thermal bridges in these structures.

*Keywords: timber building system, connections, materials, assembling methods, thermal parameters*

#### Streszczenie

W artykule omówiono przykłady nowoczesnych rozwiązań drewnianego budownictwa systemowego. Przedstawiono także początki drewnianego budownictwa systemowego, czyli budownictwo szkieletowe i masywne oraz zaprezentowano współczesne rozwiązania w porównaniu do tradycyjnych. Prezentowane w artykule systemy wybrano w taki sposób, aby pokazać różnorodność ich kształtowania – zaprezentowano przykłady systemów opartych na elementach balowych, belkowych oraz płytowych (masywnych oraz skrzynkowych). W opisie każdego z systemów przedstawiono informacje o konstrukcji elementów podstawowych, sposobach ich połączeń i materiałach użytych do ich produkcji wraz z omówieniem stopnia prefabrykacji elementów oraz sposobu ich montażu. Omówiono także zastosowania danych systemów do wznoszenia różnego rodzaju konstrukcji. W artykule zwrócono szczególną uwagę na zagadnienia fizyki budowli przegród drewnianych – parametry cieplne oraz występowanie mostków cieplnych w takich konstrukcjach.

*Słowa kluczowe: drewniane budownictwo systemowe, połączenia, prefabrykacja, montaż, parametry cieplne*

\* Ph.D. Marcin Radoń, Eng. Grzegorz Nowak, Institute of Building Materials and Structures, Faculty of Civil Engineering, Cracow University of Technology.

## 1. Types of timber building systems

A complex group of interdependent elements with specific designing, realization and technological methods allowing efficient implementation of building structure is called the technological system of building construction. Each technological system has specific materials, methods of transport, processing and embedding materials and prefabrication, selection of machinery and equipment, and work organization [1].

The basic and specific elements (logs, beams or plates) and set of connectors can be found in each system. In some of them elements are connected on the site, in others, the whole walls, ceilings, roof trusses are made in the factory and brought to the building site. Whole modules of buildings, including installations, finishing and equipment can also be produced.

Generally, systems can be divided into frame and solid structures.

## 2. Timber framing structures

Post and beam walls as well as frame structures (platform and balloon) are the traditional types of structures in this group of walls. The characteristic feature of these walls is that the structural layer and insulation fills the same space. Thermal insulation of frame walls depends largely on the use of an additional layer of insulation, which limits the thermal bridges near the frame construction elements. This additional insulation is made by the ETICS method (External Thermal Insulation Composite Systems) or by the use of hard wood frames. In this way, any required value of heat transfer coefficient can be obtained.

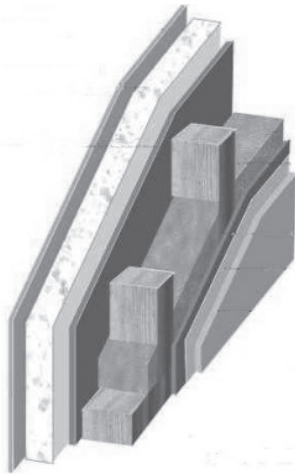

Ill. 1. Cross section of the frame wall [6]

### 2.1. Post and beam structure

This structure consists of vertical columns, horizontal beams, foundation and head beams, struts, ceiling beams and a roof structure. Traditional buildings are overlapped by the timber roof construction (rafter, span or major purlin system). Dimensions of each element are usually large (140 mm × 140 mm, 120 mm × 160 mm, 140 mm × 180 mm) due to the greater distance between the columns and beams (about 120cm) and the use of carpentry connections (notches, pins, plates). In these structures solid wood is used. A cross-section through the typical wall in the frame structure is shown in Ill. 1. The walls are filled mainly by mineral wool. From the inside vapor barrier foil should be placed and from the outside: permeable foil. Nowadays an extra layer of insulation is needed to fulfil the requirements of the Technical Conditions [4]. Roof layers are similar to the wall layers, the only difference being the cover layer (laths and battens or full boarding nailed to the rafters).

This structure is presently used for residential, farming and stockroom buildings. A modification of this structure is a half-timbered wall called a Prussian wall: a wooden frame structure filled by bricks. This structure is popular in traditional and regional buildings in the northern part of Poland.

## 2.2. Light frame structure

It is a modification of the previous type of structure, but there are no transoms or struts. Strengthening in this structure is provided by various plating (boards, wood-based plates, OSB plates or oriented strand board, plywood). Horizontal beams are inserted for installing the woodwork only above the windows and doors. There are two types of these structures: the platform structure (III. 2) and the balloon structure (III. 3).



III. 2. Platform structure [7]



III. 3. Balloon structure [7]

The main advantage of the platform structure is the independent assembly of walls and ceilings, which allows them to be made completely in the factory. An upper and lower transom connects columns and merges walls together. It is also the base for ceiling mounting. Building the balloon structure is much more labour consuming and difficult for prefabrication because the columns have a height of more than one storey. The ceiling is supported by beams.

The only difference between this structure and the post and beam structure is the spacing of structure elements. In the Polish and German module (spacing of 62.5 cm, cross-section of elements 60 mm) while in the American module (spacing of 40 cm, cross-section of elements 38 mm) is used. Elements are made from solid wood logs, laths and boards with mechanical connectors (spiked plates, nails and screws) [5].

Nowadays these structures are used to construct one-family or multifamily buildings. Several storey buildings can be built in this technology.

### 3. Massive timber structures

This group contains timber log cabin and board-patch structures. They are characterized by the separation of structure and insulation layer. In fact, to fulfil the requirements of the Technical Conditions [4] it is necessary to insulate the wall. Usually mineral wool insulation is used on the inside part of the wall to expose the wooden structure.

#### 3.1. Timber log cabin structure

This structure consists of logs arranged horizontally one on top of the other (Ill. 4). The first beam laid on the plinth, which is insulated against moisture, is called the base beam. Further beams are joined together by pins (traditional solution) or tongue and groove (modern solution). Loads are transferred directly from the ceiling and roof to the foundation by the wall beams. Logs can have different shapes (oval, rectangular or square) and size (thickness 100–300 mm). In the corners, so-called “ostatki” are used, which protect against the creation of large thermal bridges connected with the isotropic properties of wood. Because these structures are used primary for single-family houses, regional and vacational buildings, the ceilings and roofs are also made in traditional solutions [3].

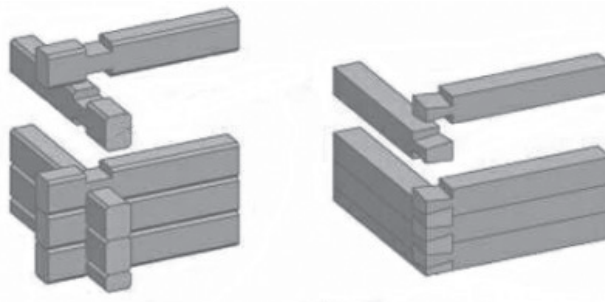

Ill. 4. Log cabin structure [8]

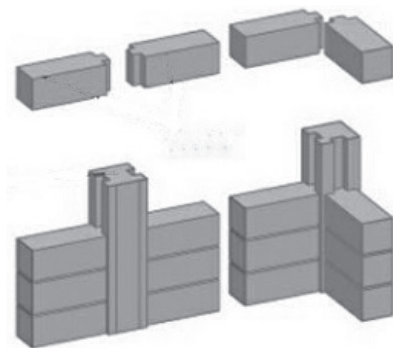

Ill. 5. Board – patch structure [8]

#### 3.2. Board-patch structure

Board-patch construction consists of vertical columns (patches), spaced at approximately 2 m with additional patches by the door and window openings, and horizontal logs (boards), which are placed at the patches by the with profiled locks (Ill. 5). The wall can also be made of two layers of boards with a layer of insulation between them [3].

#### 4. Modern timber framing structures

Systems of timber framing structures were spread in Poland in the 90s of the 20<sup>th</sup> century. These systems can be divided into several groups.

The first group is the Canadian structure. The building is made of linear elements on the site. Dimensions of the elements are the same as in the traditional frame structures. Columns, transoms, ceiling beams, foundations and head beams are made from solid wood boards, laths and logs and joined by traditional engineering connectors. Due to the low weights of items, manual assembly is used.

The second group is the Scandinavian structure shown in Ill. 6. In this case the building is made of prefabricated plates, which vary depending on their use (wall, roof, ceiling plates). Construction of wall and roof panels is usually similar; there are only different cross sections of the construction frame and thickness of the filling. The frame is built by  $50 \times 10$  mm columns spaced at 60 cm and connected at the top and bottom by transoms with nails or screws. The frame is filled by mineral wool of the same thickness as the structure (100, 125, 140, 150, 175 mm). The frame is secured from the inside by a vapor barrier foil and coated on both sides by hardboard, OSB plate, plywood or chipboard. The height of the wall panel is usually equal to the height of the storey. Ceiling construction depends on the specific system, but generally there are two solutions. The first one consists of laying down the roof plates on timber beams, which are the main structure. The second solution uses plates with bigger element sections. Roof structure can also be made in two solutions. Prefabricated roof trusses are popular in non usable lofts while rafters with roof plates are used in usable lofts.



Ill. 6. Scandinavian structure [9]

After the assembly of prefabricated elements, an extra insulation layer can be used. It adequately limits the thermal bridges. When appropriately thick insulation is used, thermal bridges are negligibly small. This layer can be made on a wooden shelf filled with wool or by the ETICS method. Assembly of the elements can be done manually or mechanically depending on the system. Wall panels weigh 130–330 lb. A crane is necessary if prefabricated trusses are used. Nowadays, there are a greater variety of buildings constructed using this technology in Poland.

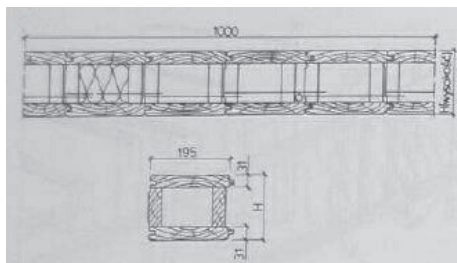

Ill. 7. Box element [1]

The next group includes box section plates (Ill. 7). Elements have various dimensions depending on the use of the system. Due to

the favourable weight to load ratio, these panels are often used in warehouses and industrial halls.

These panels are made of planks, plywood or hardboard and glued or bonded with screws. The plates are produced with a height from about 120 mm to 320 mm and a span of 16 m. Typically, the width of plates is adapted to the system module and is about 0.5–1 m. The external components (walls and roof) are filled by insulating material with vapor barrier foil on the inside. Roof structure is usually formed by laminated timber trusses. Plates are laid on them without the purlin system. This technology does not usually apply additional insulation from the outside. After the assembly of the elements, the structure is covered by plastics or brass facing.



III. 8. Assembly of plate elements [10]

systems are also used in single-family houses (systems in Alpine regions). In these systems, special connectors developed by specific producers are used. The beam systems are covered by plate panels (III. 8) and filled by an insulation layer of foils. The advantage of such solutions is the easy placement on any type of installation cables.

Because of the relatively large height of beams and columns, this system does not need an additional layer of insulation. These building systems fulfil the insulation requirements.

The last group is module technology shown in III. 9. The degree of prefabrication here is the highest and the spatial modules are only installed on the site with vertical and horizontal timber frames fully or partially closed. Depending on the system, elements have walls, ceilings,

Installation of such construction is carried out by using a crane (the components' weight is approximately 1800 lb).

The next group is created by buildings made of various types of beams. The most common are rectangular or I-joist beams (solid or openwork). For example, belts in I-joist beams can be made of laminated timber and webs of fibreboard or OSB plates. Beams are selected depending on the span and spacing. In the halls, the height of the beams reaches up to 500 mm while in residential buildings it is 200 mm. Column spacing ranges from 2 to 8 m.

For the assembly of hall system buildings, a crane is used. The elements are combined using standard engineering connections; however, beam

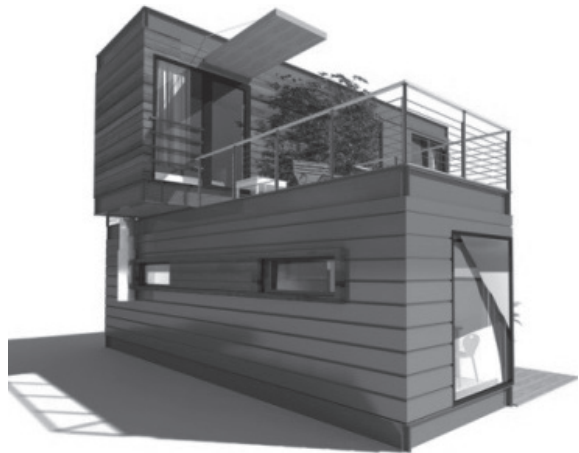

III. 9. Module house [11]



floors and even installations, finished partitioning and equipment (each module is a separate room or set of rooms).

Assembly on the site is limited to making foundations and fixing modules. The advantage of this system is possibility to move the building easily and the high speed of execution.

## 5. Modern massive structures

Massive systems, similar to frame structures, are very various. On the market there are systems based on old timber log cabin structures and structures composed mostly of laminated timber plates. A log structure element is shown in Ill. 10.

Modern timber log cabin structures are made of properly profiled logs and insulated from the inside. An interesting solution is connecting the frame and massive structures by making logs which are made of boards connected with polyurethane foam in the expansion process. The boards act as a structural (transfer bending forces) and clad material (large capacity allows for assembly of heavy façade, hanging shelves etc.). Polyurethane foam transfers shear forces. Such elements are placed vertically, joined by locks and turned by the screws.

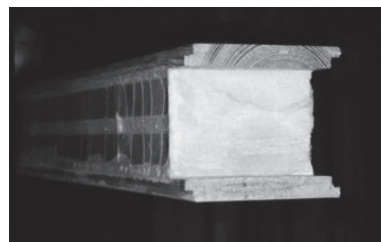

Ill. 10. Log structure element [7]

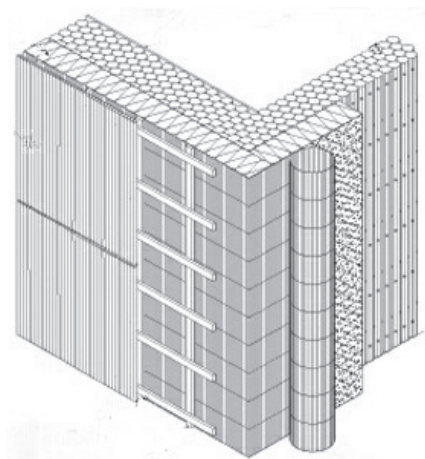

Ill. 11. Palisadio system [12]

In this system corners, windows, doors and ceiling elements are produced.

Another interesting log system is a structure based on solid wood stakes which are connected by wooden beech pins (Ill. 11). This gives great freedom in forming the shape of the building. Elements are also joined at an angle, which allows an easy connection between the wall and the roof. Non insulated walls composed of 5 stakes have a heat transfer coefficient at the level of  $0.27 \text{ W}/(\text{m}^2\text{K})$ . In addition, this wall can be insulated from the inside or the outside. Assembly of these structures is carried out mostly by hand because of the low weight of the elements.

The second group of massive structure is a system made of plate elements. These are systems dedicated to housing and public buildings. Depending on the purpose, plates made of three, five or seven board layers with a thickness of 18–32 mm glued by epoxy resin are produced (Ill. 12). The load capacity of such a ceiling is similar to ceilings made of concrete.

Structures made from these elements should be further insulated. It is made similarly to masonry structures using the ETICS method or a heavy wood frame filled with mineral wool.



III. 12. Timber glued elements [13]

Plates, which are brought to the site, have the size of the whole or part of the wall. Ceiling and roof plates have a width of 120 cm so assembly is done with the use of a crane.

The next system is based on small-sized wood elements shown in Ill. 13. A building in this technology is made in the same way as a building in masonry structure. Items are usually larger than in masonry systems because of smaller wood volume weight. They are joined with pins, screws, bolts and tongue and groove. Ceilings can be made of laminated timber. Any roof structure can be used: traditional or prefabricated. The walls are made manually, however, for the assembly of the ceiling or roof, a crane is usually needed.



III. 13. Small – sized wood elements [14]

Buildings in this technology should be thermally insulated. These systems are designed primarily for single-family housing.

## 6. Conclusions

Timber structure systems are a good alternative to traditional masonry and reinforced concrete systems which are very popular in Poland. The advantages of system solutions are first of all the speed and accuracy of the assembly and the ability to achieve high thermal insulation. There is a variety of timber technology, so the most suitable system for the building can always be chosen.

## References

- [1] Jasiczak J., *Technologie budowlane II*, Politechnika Poznańska, Poznań, 01/2003.
- [2] Sherwood G., *Budowa szkieletowego domu drewnianego*, Wydawnictwo Murator, Warszawa 1996.
- [3] Praca zbiorowa pod kierunkiem Wiesława Buczkowskiego, *Budownictwo ogólne tom 4*, Arkady, Warszawa 2009.
- [4] Rozporządzenie Ministra Infrastruktury w sprawie warunków technicznych, jakim powinny odpowiadać budynki i ich usytuowanie z dnia 12 kwietnia 2002 r. (Dz.U. 75, poz. 690) z późniejszymi zmianami.
- [5] Katalog, *System Kronopol*, Żary 2003.
- [6] [www.domyprefabrykowane.com](http://www.domyprefabrykowane.com); access: 15.09.2013.
- [7] [www.szkielet.pl](http://www.szkielet.pl); access: 15.09.2013.
- [8] [www.porady-budowlanka.blogspot.com](http://www.porady-budowlanka.blogspot.com); access: 15.09.2013.
- [9] [www.e-dobrydom.com](http://www.e-dobrydom.com); access: 15.09.2013.
- [10] [www.drewno.pl](http://www.drewno.pl); access: 15.09.2013.
- [11] [www.behance.net](http://www.behance.net); access: 15.09.2013.
- [12] [www.bba-online.de](http://www.bba-online.de); access: 15.09.2013.
- [13] [www.trae.dk](http://www.trae.dk); access: 15.09.2013.
- [14] [www.zimmereistopper.de](http://www.zimmereistopper.de); access: 15.09.2013.



MAŁGORZATA ROJEWSKA-WARCHAŁ\*

## THE INFLUENCE OF GLAZING TYPE, FRAME PROFILES SHAPE AND SIZE OF THE WINDOW OF THE FINAL VALUE OF WINDOW THERMAL TRANSMITTANCE $U$

### ANALIZA WPŁYWU PRZESZKLENIA, RAM ORAZ KSZTAŁTU I WIELKOŚCI OKIEN NA WSPÓŁCZYNNIK PRZENIKANIA CIEPŁA $U$

#### Abstract

The paper presents the analysis of the relation between window thermal transmittance and the window shape, size, frame profile, glazing type and opening area division. The analysis was performed in the Window 6.3 program developed by the Lawrence Berkeley National Laboratory, which has the possibility of a comprehensive analysis of the heat flow through the various types of windows, according to the current assessment procedure developed by the National Fenestration Rating Council (NFRC) and comply with ISO 15099. For the purpose of the analysis a number of computer simulations of various window frames were conducted.

*Keywords: thermal transmittance, energy efficient windows*

#### Streszczenie

W referacie podjęto próbę analizy zależności wielkości współczynnika przenikania ciepła  $U$  dla okien w zależności od kształtu, wymiarów, rodzaju ram, podziału i typu zastosowanego zestawu szybowego. Analizę przeprowadzono w programie Window 6.3 opracowanym przez Lawrence Berkeley National Laboratory, który ma możliwość wszechstronnej analizy przepływu ciepła przez różnego rodzaju okna, zgodnej z aktualną procedurą oceny opracowaną przez National Fenestration Rating Council (NFRC) i zgodną z normą ISO 15099. Dla celów analizy przeprowadzono szereg symulacji komputerowych dla różnych rozwiązań ram okiennych.

*Słowa kluczowe: współczynnik przenikania ciepła, okna energooszczędne*

\* M.Sc. Małgorzata Rojewska-Warchał, Division of Building and Building Physics, Faculty of Civil Engineering, Cracow University of Technology.

## 1. Introduction

Windows are important elements of energy efficient buildings in terms of developing thermal balance. The significance of heat loss through windows depending on their shape and on the architectural and construction solutions, may constitute an important element in the total thermal balance of a building. The growing costs of maintenance are spent on balancing the heat loss via glass surfaces in winter months and for the maintenance of cooling systems in summer. While designing a window, it should be taken into account that not only does its construction influence the aesthetic features of a building and the amount of sunlight let inside, but also it influences the thermal transmittance  $U$ . It is not enough to determine the thermal parameters of windows  $x$  by only providing the thermal transmittance  $U_g$  of the glass surfaces. The thermo-insulating properties of a glass pane are only a component parameter of the total value of the thermal transmittance of a window unit  $U_w$ . In recent years the thermo-insulating power of windows has improved due to the use of new window profiles with insulation layers and glazing filled not only with air but also with special gases.

The heat transfer through windows is characterized by very complex physical phenomena and so the thermal characterizations of windows are determined on the basis of laboratory research and complex numerical analysis of thermal balance done with the use of computer simulations. Thanks to computer simulations the thermal transmittance  $U_w$  may be described as a function of the type, shape and size of a frame, of the glass surfaces, and the type of gas filling the glazing cavity.

The analysis was conducted in the Window 6.3 program developed by the Lawrence Berkeley National Laboratory, which gives the opportunity to perform a comprehensive analysis of heat conduction in various types of windows in agreement with the current procedures of assessment as developed by the National Fenestration Rating Council (NFRC) in accordance with the ISO 15099 norm.

## 2. Determining thermal transmittance

The value of the total thermal transmittance for windows is calculated in accordance with the norm [2] in the following way:

$$U_w = \frac{\Sigma A_g \times U_g + \Sigma A_f \times U_f + \Sigma l_g \times \Psi_g}{\Sigma A_g + \Sigma A_f} \quad (1)$$

where:

- $U_g$  – the thermal transmittance of the glass [W/m<sup>2</sup>K],
- $U_f$  – the thermal transmittance of the framing [W/m<sup>2</sup>K],
- $\Psi_g$  – the linear thermal transmittance resulting from the combination of the heat effects of the glass and the frame [W/mK],
- $A_g$  – the surface of the glass [m<sup>2</sup>],
- $A_f$  – the surface of the frame [m<sup>2</sup>],
- $l_g$  – the perimeter of the glass element [m].

It is a complicated process to determine an individual thermal transmittance included in the equation (1). When determining the thermal transmittance for the central area  $U_g$  of the window, one should perform a simulation analysis, which takes into account the heat conduction through glass surfaces, radiation and convection heat transmission of the glazing cavities, the number of glass panes in the glazing as well as the climatic conditions, indoor temperature and the angle of the window. Due to its dual nature, the heat transfer through the area by the edge is significantly different from the heat transfer through the central area. Materials used for insulation layers between the glass panes in the areas by the edge of the glazing, have greater thermal conductivity than the gas layers in the glazing cavities.

An analysis of two-way heat transfer, which takes into account the different conductivity, would complicate the calculation of the heat balance of the entire window. A simplification was adopted on the basis of x tests of the area of the glazing by its edge conducted in the United States. The area by the edge was defined as the area limited by the frame and the line placed at a distance of 63.5 mm [4] from the edge. The thermal transmittance of the frame depends on the type and the material from which it is made and on the presence of thermal bridges, because the dominant mode of heat transfer in all types of frames is conduction.

### 3. Subject of the analysis

The analysis was conducted in the Window 6.3 program developed by the Lawrence Berkeley National Laboratory. The computational analysis was conducted with reference to the following assumptions:

- In all of the analyzed cases, x glass of 4mm thickness was adopted

Table 1

#### The optical properties of the glass used in the glazing

Type of glass	$T_{sol}$	$R_{sol1}$	$R_{sol2}$	$T_{vis}$	$R_{vis1}$	$R_{vis2}$	$T_{ir}$	emis1	emis2	$\lambda$ W/m <sup>2</sup> K
P	0,847	0,078	0,078	0,902	0,081	0,081	0,000	0,840	0,840	1,0
PNE	0,708	0,116	0,127	0,833	0,109	0,166	0,000	0,840	0,149	1,0
PSS1	0,569	0,268	0,310	0,855	0,082	0,075	0,000	0,837	0,037	1,0
PSS2	0,370	0,341	0,470	0,765	0,074	0,055	0,000	0,840	0,037	1,0

P – clear glass,

PNE – clear glass with low emissivity,

PSS – spectrally selective clear glass,

$T_{sol}$  – transmissivity of solar radiation through the glass,

$R_{sol1}$ ,  $R_{sol2}$  – reflectivity of solar radiation through glass,

$T_{vis}$  – transmissivity of solar radiation through the glass,

$R_{vis1}$ ,  $R_{vis2}$  – reflectivity of visible radiation through the glass,

$T_{ir}$  – transmissivity of infrared radiation through the glass,

emis1, emis2 – emissivity of infrared radiation through the glass, respectively the glass surface from the outside and inside.



- Double-pane glazing and triple-pane glazing were adopted

Table 2

**Thermal properties of glazing used (central surface)**

Type of glazing	The heat transmittance $U_g$ [W/m <sup>2</sup> K]
Double-pane glazing	
P – Argon – P	2.575
PNE – Argon – PNE	1.309
Triple-pane glazing	
PSS1 – Argon – PSS1 – Argon – PSS1	0.595
PSS2 – Argon – PSS2 – Argon – PSS2	0.594

The values refer to the central area of the window shown in Ill. 1.

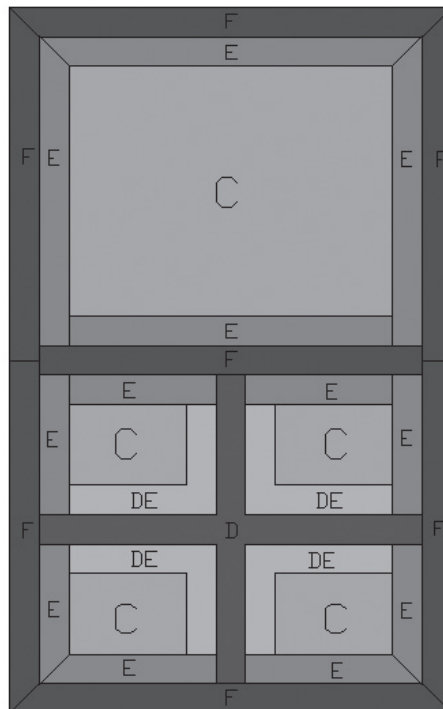

Ill. 1. The division of the surface of the window into fragments: centre-of-glass C, edge-of-glass E, divider D, divider-edge DE, and frame areas F for a typical fenestration product

- The adopted frames were made from PVC, wood and aluminum with various thermal transmittance  $U_f$

The following types of window frames and their thermal transmittance are currently used profiles in residential and public buildings: 5 – and 6 – chamber PVC profiles and wooden profiles used in conventional buildings, and 6 – chamber profiles with increased depth and 8 – chamber PVC profiles in energy efficient buildings. Aluminum profiles are mostly used in public buildings.

Table 3

### Thermal properties of window frames in use

Type of profile	The thermal transmittance $U_f$ [W/m <sup>2</sup> K]
PVC	
5 – chamber profile with the depth of 70 mm and the width of the 112 mm of the combination	1.3
6 – chamber profile with the depth of 70 mm and the width of the 112mm of the combination	1.03
6 – chamber profile with the depth of 88 mm and the width of the 125 mm of the combination	0.9
8 – chamber profile with the depth of 70 mm and the width of the 112 mm of the combination	0.96
WOOD	
Glulam with the depth of the profile of 68	1.5
Glulam with the depth of the profile of 78	1.4
ALUMINUM	
A profile with the depth of 51mm and the width of frame of 108 mm	2.6
A profile with the depth of 69mm and the width of frame of 114 mm	2.0

- simulation analyses were carried out in relation to the following types of windows (the size were taken from currently produced windows):

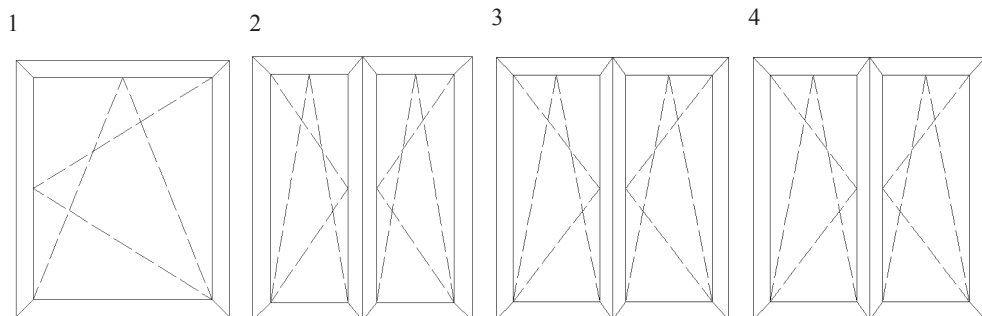

III. 2. Types of windows: 1) 1230 × 1480 mm, 2) 1230 × 1480 mm, 3) 1465 × 1435 mm 4) 2065 × 1839 mm

These types of windows were adopted because, according to the equation (1) it is clear that an important parameter affecting the overall thermal transmittance is not only the size, but also the division of the glazing. The ratios between the size of the glass panex and the frame have a significant effect on the overall thermal transmittance.

#### 4. Results of the analysis

Simulation analyses of the total thermal transmittance for each variant were done in the Window 6.3 program and the results are shown in Table 4a and 4b, 5a and 5b.

Table 4a and 4b

#### The thermal transmittance for windows with PVC frames for all kinds of sizes, profiles and window glazing

System		1230 × 1480 mm area. 1.832 m <sup>2</sup> Window No. 1			1230 × 1480 mm area. 1.832 m <sup>2</sup> Window No. 2		
		$U_w$			$U_w$		
$U_f$		$U_g = 2.575$	$U_g = 1.3$	$U_g = 0.6$	$U_g = 2.575$	$U_g = 1.3$	$U_g = 0.6$
1	1.3	<b>2.258</b>	1.469	1.069	<b>2.210</b>	1.561	1.251
2	1.03	<b>2.175</b>	1.386	0.986	<b>2.105</b>	1.458	1.148
3	0.96	<b>2.153</b>	1.365	0.965	<b>2.078</b>	1.431	1.121
4	0.90	<b>2.080</b>	1.330	0.950	<b>1.978</b>	1.385	1.099

System		1465 × 1435 mm area. 2.168 m <sup>2</sup> Window No. 3			2065 × 1839 mm area. 3.798 m <sup>2</sup> Window No. 4		
		$U_w$			$U_w$		
$U_f$		$U_g = 2.575$	$U_g = 1.3$	$U_g = 0.6$	$U_g = 2.575$	$U_g = 1.3$	$U_g = 0.6$
1	1.3	<b>2.238</b>	1.537	1.190	<b>2.301</b>	1.456	1.050
2	1.03	<b>2.143</b>	1.441	1.096	<b>2.229</b>	1.394	0.979
3	0.96	<b>2.119</b>	1.417	1.07	<b>2.211</b>	1.375	0.960
4	0.90	<b>2.035</b>	1.375	1.052	<b>2.147</b>	1.346	0.948

The figures in bold in the table show the thermal transmittance in excess of  $U_{max}$  which define the current technical specifications [1].

The thermal transmittance is not dependent on the surface of the window, but on the ratio of the central area, x the area by the edge and their thermo-insulating properties. While designing windows none of the elements should be neglected as their insulating power and the surfaces they take up may deteriorate or improve the thermo-insulating power of the windows, which is shown in detail in tables 4a and 4b as well as 5a and 5b.

**The thermal transmittance for windows with wooden and aluminum frames of all kinds of sizes, profiles and window glazing**

System		1230 × 1480 mm surface. 1.832 m <sup>2</sup> Window No. 1			1230 × 1480 mm surface. 1.832 m <sup>2</sup> Window No. 2		
		$U_w$			$U_w$		
$U_f$		$U_g = 2.575$	$U_g = 1.3$	$U_g = 0.6$	$U_g = 2.575$	$U_g = 1.3$	$U_g = 0.6$
wood_1	1.5	<b>2.302</b>	1.542	1.141	<b>2.264</b>	1.644	1.349
wood_2	1.4	<b>2.226</b>	1.499	1.131	<b>2.168</b>	1.595	1.322
aluminum_1	2.6	<b>2.655</b>	<b>1.855</b>	1.448	<b>2.707</b>	<b>2.046</b>	1.728
aluminum_2	2.0	<b>2.469</b>	1.686	1.289	<b>2.473</b>	<b>1.833</b>	1.526

System		1465 × 1435 mm surface. 2.168m <sup>2</sup> Window No. 3			2065 × 1839 mm surface. 3.798 m <sup>2</sup> Window No. 4		
		$U_w$			$U_w$		
$U_f$		$U_g = 2.575$	$U_g = 1.3$	$U_g = 0.6$	$U_g = 2.575$	$U_g = 1.3$	$U_g = 0.6$
wood_1	1.5	<b>2.289</b>	1.606	1.271	<b>2.340</b>	1.520	1.113
wood_2	1.4	<b>2.201</b>	1.567	1.265	<b>2.273</b>	1.429	1.105
aluminum_1	2.6	<b>2.693</b>	<b>1.977</b>	1.625	<b>2.645</b>	<b>1.799</b>	1.378
aluminum_2	2.0	<b>2.479</b>	1.783	1.441	<b>2.484</b>	1.653	1.241

Based on the simulation analysis it has been shown that independently of the dimensions and the window profiles used, the windows with the glazing of the highest thermal transmittance  $U_g = 2.575$  W/m<sup>2</sup>K do not fulfill the requirements in the current Technical Conditions [1].

A single window with the dimensions of 1230 × 1480 mm has in all cases a lower thermal transmittance than a double window of the same dimensions with the exception of windows with the glazing of  $U_g = 2.575$  W/m<sup>2</sup>K. The greater the share of the glazing with good insulating properties  $x$ , the lower the thermal transmittance  $x$ .

The improvement of the thermal transmittance of the central area may be achieved by using multiple glazing made of glass with low emissivity with layers of gas with high thermo-insulating power. A comparison of a double-pane glazing consisting of clear glass and filled with argon  $U_g = 2.575$  W/m<sup>2</sup>K with a triple-pane glazing consisting of clear spectrally selective glass also filled with argon  $U_g = 0.6$  W/m<sup>2</sup>K shows that the thermal transmittance has decreased by four times. The use of a gas or a mixture of gases with a lower thermal transmittance than argon would also improve the heat transmittance of the central area.

The insulating powers of the frame are primarily dependent on the thermo-insulating powers of the used materials. The frame is also an element which may significantly influence the insulating power of the window, which is shown in tables 4a and 4b, 5a and 5b.

The conducted analysis took into account the available glazing, with reference to various properties of the glass, the use of selective layers and the filling of the glazing cavity with varied

types of gases. This may play an important role at the stage of performing an energetic audit and design. The outcome of the analysis together with the scope of variability dependent on the adopted configuration may be beneficial as input data in simulation programs calculating the annual demand for energy of buildings with particular attention paid to buildings with high degree of glazing in the elevation.

## References

- [1] Dz. U. 2002 Nr 75 poz. 690, Rozporządzenie Ministra Infrastruktury z dnia 12 kwietnia 2002 r. w sprawie warunków technicznych, jakim powinny odpowiadać budynki i ich usytuowanie.
- [2] PN-EN ISO 10077-1:2007, Właściwości cieplne okien, drzwi i żaluzji. Obliczanie współczynnika przenikania ciepła – część 1: Metoda uproszczona.
- [3] PN-EN ISO 10077-2:2012, Ciepłne właściwości użytkowe okien, drzwi i żaluzji. Obliczanie współczynnika przenikania ciepła – część 2: Metoda komputerowa dla ram.
- [4] ISO 15099:2003, Thermal performance of windows, doors and shading devices – Detailed calculations.
- [5] Nowak H., *Analiza i ocena możliwości kształtowania bilansu cieplnego okien*, Okno, nr 1 (8) styczeń – marzec 1997, 196-204.

ANNA ZASTAWNA-RUMIN\*

## PHASE CHANGE MATERIALS VS. INTERNAL TEMPERATURE IN A BUILDING

### MATERIAŁY FAZOWO-ZMIENNE A TEMPERATURA WEWNĄTRZ POMIESZCZEŃ

#### Abstract

The article presents results of simulation of building assuming presence of phase change material in wall barriers. Obtained results were compared with the ones of a building without phase change material in wall barriers. Object of comparing calculations is a model of a real service building located in Silesia. It has light-frame construction with light covering (external metal sheet, heat-insulation, interior metal sheet). In subsequent examinations, the presence of 1 cm thick PCM board placed under the inner surface of a metal sheet was assumed. Tests were conducted for organic materials that undergo phase transition in different temperatures such as 23°C, 25°C, 27°C or 29°C. Based on results of operative temperature measurements, it is possible to determine PCM influence on the building overheating risk.

*Keywords: heat capacity, phase change material*

#### Streszczenie

W artykule przedstawiono wyniki symulacji budynku, zakładając wbudowanie w jego przegrody materiału fazowo-zmiennego. Wyniki porównywano do stanu wyjściowego (bez PCM). Przedmiotem porównawczych obliczeń jest model istniejącego budynku o charakterze usługowym, zlokalizowany w województwie śląskim. Budynek ma konstrukcję szkieletową z lekkim poszyciem (blacha elewacyjna, termoizolacja, blacha konstrukcyjna). W kolejnych wariantach pod powierzchnią blachy od strony wewnętrznej założono wbudowanie PCM w postaci mat o grubości 1 cm. Materiałem ulegającym przemianie fazowej jest materiał organiczny. Analizie poddano warianty z zastosowaniem PCM o różnej temperaturze przemiany fazowej, tj. 23°C, 25°C, 27°C. Na podstawie wyników temperatury operatywnej można określić wpływ MFZ na ryzyko przegrzewania budynku.

*Słowa kluczowe: pojemność cieplna, materiały fazowo-zmienne*

\* M.Sc. Anna Zastawna-Rumin, Institute of Building Materials and Structures, Faculty of Civil Engineering, Cracow University of Technology.

## 1. Introduction

The aim of placing PCM into building elements is to increase heat capacity of a building. Excessively low heat capacity results in deficiency of heat stability in very popular light-frame construction with light filling wall barriers that cause seasonal overheating of a building and large temperature oscillations of internal air during temperature changes of external air.

The idea of using phase change materials to accumulate heat is built on an energy saving process such as latent heat of organic compounds e.g., paraffins, fatty acids or inorganic salt hydrates. Accumulation or emission of large amounts of heat occurs during phase transition and is accompanied with a small temperature change of a specific PCM.

## 2. Purpose of the article

The aim is to determine the influence of phase change materials on internal temperature of an examined object and thermal stability. Both internal air temperature and internal surface temperature of wall barriers were tested. Examination was conducted with particular consideration of thermal parameters influencing thermal comfort and determination of the building overheating risk.

## 3. Analysis

### 3.1. Description of the calculation model

The object of comparing calculations is a model of a real service building located in Katowice. It has light-frame construction with light covering. The floor is constructed with 10 cm layer of concrete. Object dimensions are 15 m × 30 m × 6 m (Ill. 1).

In initial condition, elevation is constructed with 15 cm thermal insulation bound by metal sheets from each side. In the next variant, the PCM was built in as a 1 cm layer, located from the internal side of a wall. To analyze this, an organic kind of Phase Change Material was used. In simulation, all available variants of PCM were used. The difference between variants was the temperature of phase changing at 23°C, 25°C, 27°C (in this article, variants were called consecutively PCM 23, PCM 25, PCM 27, PCM 29). Adopted to calculation, dependence of the enthalpy of the temperature for the PCM, is illustrated in Ill. 2 [2]. All other material data are presented at Table 1.



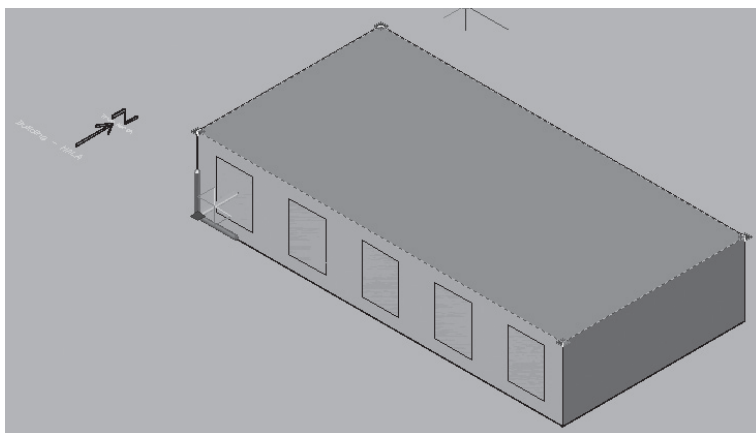

III. 1. Visualization of analyzed building

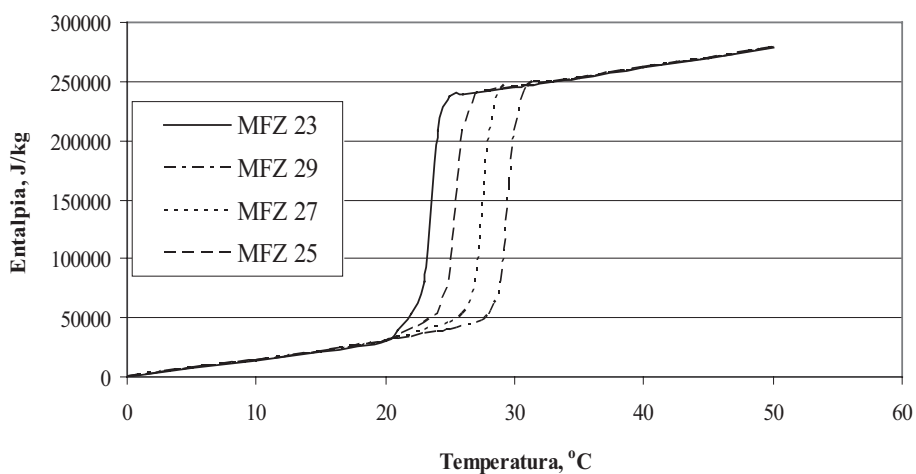

III. 2. Relationship between enthalpy and temperature for the analyzed PCM [2]

Table 1

Material data [3, 4, 7]

Material	Thickness [m]	$\lambda$ [W/mK]	Specific heat [J/kgK]	Thermal absorptance	Solar absorptance
External metal sheet	0.001	58	500	0.9	0.4
Thermal-insulation	0.15	0.04	1381	0.9	0.7
PCM	0.01	0.2	$c_w(T)$	0.9	0.7
Interior metal sheet	0.001	58	500	0.9	0.4

The wall glazing is composed of 5 big windows with the dimensions of  $3 \times 4$  m. The windows are located at the south side of the building. It is assumed that there are 10 persons in the building simultaneously during working hours and that it is also necessary to use additional interior lighting. In order to this during working hours (i.e., 7 am to 6 pm) heat gains from people (80 W per person) and lighting ( $3 \text{ W/m}^2$ ) were added. In the simulation, weather data for the period from 1.06 to 1.09 was adopted. A 0,5 outdoor air change per hour was also assumed. All simulations were performed in Energy Plus ver. 7.1 application, which allows the modeling of phase transition of chosen materials and is able to provide for unsteady external conditions.

### 3.2. Simulation results

The operative interior temperature of the object has been analyzed. On the operative temperature (wind chill) both interior air temperature and the temperature of the barriers have influence. Ill. 3, 4 and 5 show graph of the operative temperature inside the building in the analyzed period with different material variants (without PCM, PCM with different point of phase change  $23^\circ\text{C}$ ,  $25^\circ\text{C}$  and  $27^\circ\text{C}$ ).

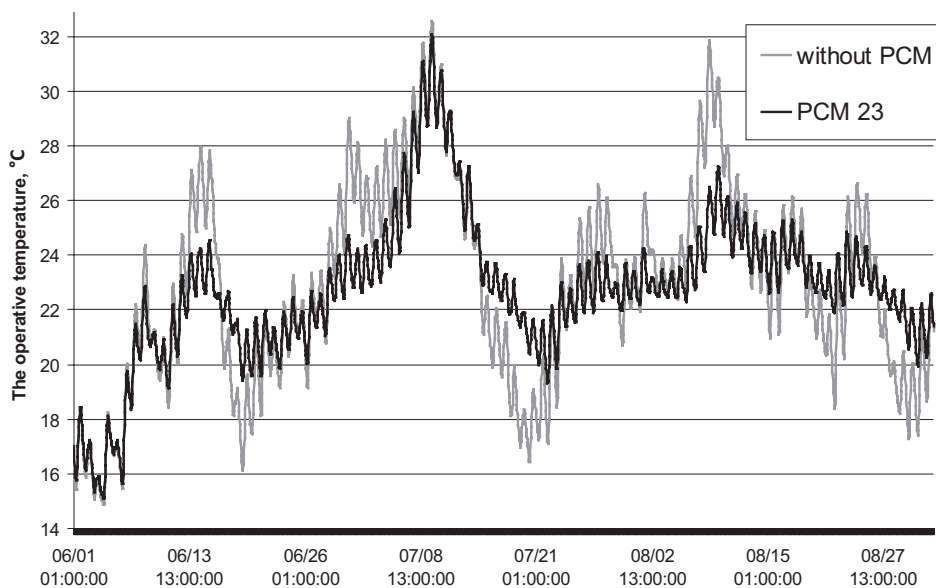

Ill. 3. The operative temperature inside the building in analyzed period without PCM and with PCM 23

Regardless of the type of PCM installation it is always visible that the graph is smoother in comparison to the baseline. That demonstrates the much higher thermal stability of the object and reduction of the impact of outside temperature. Maximum wind chill that occurs in this variant is at  $32.57^\circ\text{C}$  (base variant),  $32.07^\circ\text{C}$  (with PCM 23),  $30.45^\circ\text{C}$  (with PCM 25)

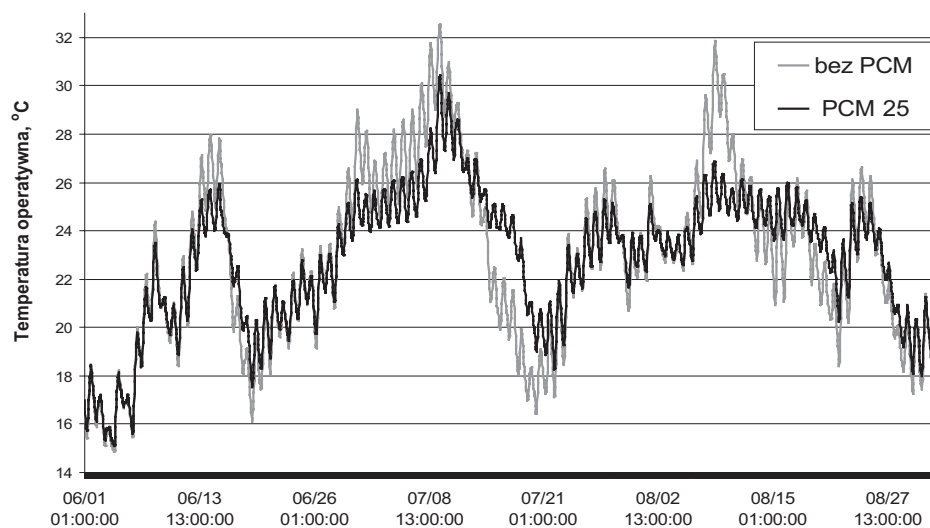

III. 4. The operative temperature inside the building in analyzed period without PCM and with PCM 25

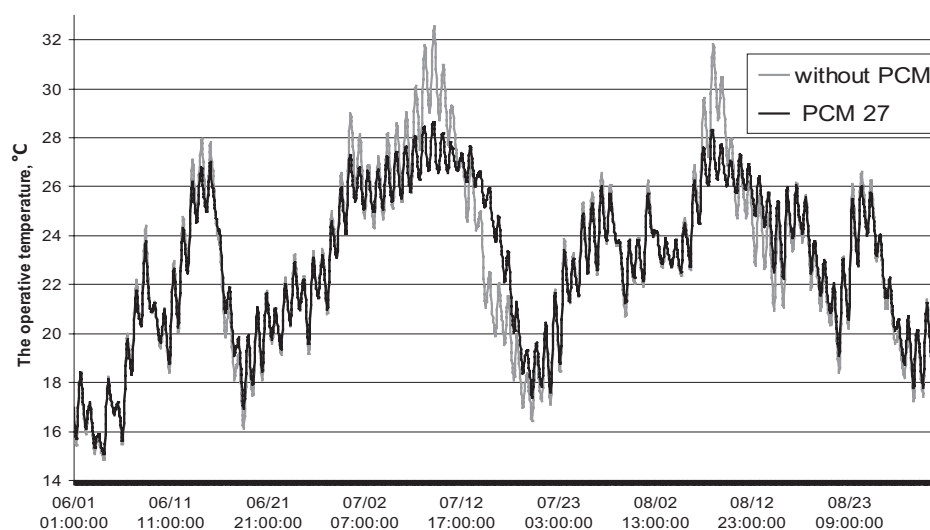

III. 5. The operative temperature inside the building in analyzed period without PCM and with PCM 27

and 28.65°C (with PCM 27). Thus, the largest reduction of the maximum temperature can be achieved by using PCM 27. Material variants were also analyzed in terms of efficiency; the difference between the interior operative temperature with incorporated PCM and without PCM, were calculated at each time step. The maximum difference of instantaneous values occurred at variant PCM 23 with the value of 5.44 K (in next variants: PCM 25  $\Delta t_{\max} = 5.25$  K, PCM 27  $\Delta t_{\max} = 5.10$  K). In order to take into account the frequency, all

positive  $\Delta t$  were integrated. As presented in Table 2, the maximum sum of positive  $\Delta$ , the frequency of occurrence and the average value of  $\Delta$  indicate that PCM 23 has the highest efficiency.

Table 2

#### Analiza rozwiązań z różnymi rodzajami PCM

Wariant	PCM 23	PCM 25	PCM 27
$\max \Delta t = t_{\text{operative}} - t_{\text{operative}}^{\text{PCM}}$ , K	5.44 K	5.25 K	4.1 K
Sum $\Delta t > 0$ , °C	1601	1155	677
Frequency $\Delta t > 0$	1231	1098	973
Mean $\Delta t$ , °C	1.30	1.05	0.70

As presented in Table 3, using the PCM 23 causes the biggest reduction of total time with the temperature over 24°C (limit of thermal comfort). The length of that term was shortened by over 38% in comparison to the variant without PCM. When PCM 25 is incorporated, a very large (over 75%) reduction of term with temperature over 27°C is achieved. It is very important due to the thermal sensitivity of people because temperature above 27°C is not tolerated by the human body. The application of PCM 27 will completely remove the term of maximum temperature (above 29°C), but at the same time maintains a long total period exceeding both temperatures of 27°C and 24°C.

Table 3

#### Number of hours when internal temperature was over internal temperature setpoint

Temperature, °C	> 24	> 25	> 26	> 27	> 28	> 29	> 30	> 31	> 32
<b>Variant</b>									
<b>without PCM</b>	855.85	630.25	442.85	285.30	181.20	115.00	61.00	25.85	6.30
<b>PCM 23</b>	<b>527.95</b>	296.05	190.60	140.00	93.85	62.95	32.85	11.30	1.80
<b>PCM 25</b>	898.35	477.30	187.10	<b>79.55</b>	45.75	18.65	4.80		
<b>PCM 27</b>	933.95	706.70	429.05	159.50	32.85				

## 4. Conclusions

The incorporation of PCM inside external barriers of the building causes a risk of interior overheating. Results of the simulation indicate that the most efficient solution is the incorporation of a material which has the point of phase change at 23°C. This is probably due to the high frequency of occurrences of that temperature range and the point of phase change of the material in that range. Using PCM 23 causes the greatest reduction of total time with the temperature over 24°C. Solutions with PCM 25 and PCM 27 perform effectively only in

the case of higher temperature. To determine which option is more comfortable for the people inside a building, it would be required to deeply analyze the problem in terms of the thermal comfort, with consideration to the length of the peak temperature period for each day.

### References

- [1] Wnuk R., *Magazynowanie ciepła, pozyskanego z energii promieniowania słonecznego, z wykorzystaniem materiałów fazowo-zmiennych, w budownictwie*, II Konferencja SOLINA 2008, Innowacyjne Rozwiązania. Materiały i Technologie dla Budownictwa, Solina 2008, 521-528.
- [2] Muruganantham K., *Application of Phase Change Material in Buildings: Field Data vs. EnergyPlus Simulation*, Arizona State University, 2010.
- [3] Pogorzelski J.A., *Fizyka ciepła budowli*, Państwowe Wydawnictwo Naukowe, Warszawa 1976.
- [4] Bogusławski W.N., *Fizyka budowli*, Arkady, Warszawa 1975.
- [5] Dz. U. 2002, Nr 75, poz. 690, Rozporządzenie Ministra Infrastruktury z dnia 12 kwietnia 2002 r. w sprawie warunków technicznych, jakim powinny odpowiadać budynki i ich usytuowanie.
- [6] Energy Plus Documentation, <http://apps1.eere.energy.gov>; access: 15.09.2013.
- [7] <http://www.phasechange.com/>; access: 15.09.2013.



## CONTENTS

## LANDSCAPING

M. Chudy: Vertical garden .....	5
A. Drapella-Hermansdorfer: The landscape plan for the Slezka River Park in Wrocław: new organizational and technical solutions .....	11
S. Kuc: Technologies and innovations at the IBA and IGS exhibitions – Hamburg 2013 .....	19
L. Ruban: Three states of water: how technology makes “water” a construction material.....	27

## STRUCTURES

T. Domański: Reliability of glued timber roofs belonging to CC3 class consequences of failure.....	41
R. Kinash, V. Bilozir: Deformational calculation method of bearing capability of fiber-concrete steel bending elements .....	49
R. Kinash, D. Gladyshev: Analysis of factors that influence longevity and safety of the thin-walled concrete constructions.....	59
J. Rębielak: Designing of structural systems with application of principle of superposition	71
A. Burdzińska-Sroką: Determinants of shaping an architectural form and structure in wooden halls.....	77
T. Zych: New Generation Cementitious Composites with fibres – properties and application .....	85
P. Żwirek: Selected issues of structure forming of the contemporary single and multi-curved roofs.....	103

## BUILDING PHYSICS

A. Byrdy: A moisture transfer in external walls with natural stone cladding glued directly to thermal insulation layer .....	113
A. Chądzyński: The hygrothermal aspects of forming the internal structure of the roof slope.....	121
J. Dębowski, K. Nowak, K. Nowak-Dzięszko: Airtightness of the large panel buildings before and after thermal modernization.....	129
H. Garbalińska, M. Bochenek: Airtightness of the large panel buildings before and after thermal modernization.....	137
T. Kamiński, R. Kinash, A. Pilch, J. Rubacha: The influence of new material technology on acoustic treatment of modernized interiors.....	145
T. Kisilewicz: On rational design of low energy building external components .....	153
D. Kram, K. Nowak: The impact of detail solutions in the wooden building structures on the thermal parameters of the enclosure .....	159
K. Nowak, A. Zastawna-Rumina: Examination of a wall barrier containing phase change material in a climate chamber .....	169
B. Orlik-Kozdoń, M. Włodarczyk, T. Steidl: Internal thermal insulation in the technical and architectural aspect.....	179
M. Radoń, G. Nowak: Innovative timber construction systems in terms of design and structure physics solutions .....	189
M. Rojewska-Warchał: The influence of glazing type, frame profiles shape and size of the window of the final value of window thermal transmittance $U$ .....	199
A. Zastawna-Rumina: Phase change materials vs. internal temperature in a building.....	207



## KRAJOBRAZ

M. Chudy: Wertykalny ogród.....	5
A. Drapella - Hermansdorfer: Plan krajobrazowy Parku Ślęzy we Wrocławiu: nowe rozwiązania organizacyjne i techniczne.....	11
S. Kuc: Technologie i innowacje na wystawach IBA i IGS – Hamburg 2013.....	19
L. Ruban: Zastosowanie wody w architekturze współczesnej: nowe podejście do modelowania przestrzeni.....	27

## KONSTRUKCJE

T. Domański: Niezawodność dachów z drewna klejonego o klasie konsekwencji zniszczenia CC3.....	41
R. Kinash, V. Bilozir: Odształceniowa metoda obliczania nośności zginanych elementów fibrobetonowych z włóknami stalowymi.....	49
R. Kinash, D. Gladyshev: Analiza czynników wpływających na trwałość i bezpieczeństwo cienkościennych konstrukcji betonowych.....	59
J. Rębielak: Projektowanie systemów konstrukcyjnych z zastosowaniem zasady superpozycji ..	71
A. Burdzińska - Sroka: Uwarunkowania kształtowania formy architektonicznej i konstrukcji obiektów halowych z drewna.....	77
T. Zych: Fibrokompozyty cementowe nowej generacji – właściwości i zastosowania.....	85
P. Żwirak: Wybrane zagadnienia kształtowania konstrukcji współczesnych dachów jedno- i wielokrzywiznowych.....	103

## FIZYKA BUDOWLI

A. Byrdy: Transport wilgoci przez ściany zewnętrzne z okładziną kamienną klejoną bezpośrednio do warstw izolacji termicznej.....	113
A. Chądzyński: Higrotermiczne aspekty kształtowania wewnętrznej struktury skośnej połaci dachu.....	121
J. Dębowski, K. Nowak, K. Nowak - Dzieszk: Szczelność budynków wielkopłytowych przed i po termomodernizacji.....	129
H. Garbalińska, M. Bochenek: Pogorszenie właściwości wytrzymałościowych i ciepłych betonu komórkowego w wyniku zawilgocenia kapilarnego.....	137
T. Kamisiński, R. Kinash, A. Pilch, J. Rubacha: Wpływ nowych technologii materiałowych na adaptację akustyczną modernizowanych wnętrz.....	145
T. Kisilewicz: O racjonalnym kształtowaniu niektórych elementów obudowy zewnętrznej budynków niskoenergetycznych.....	153
D. Kram, K. Nowak: Wpływ rozwiązań detali w budynkach o konstrukcji drewnianej na wartości parametrów cieplnych obudowy.....	159
K. Nowak, A. Zastawna - Rumina: Badanie przegrody zawierającej materiał fazowo-zmienny w komorze klimatycznej.....	169
B. Orlik - Koźdoń, M. Włodarczyk, T. Steidl: Ciepłe izolacje wewnętrzne w aspekcie technicznym i architektonicznym.....	179
M. Radoń, G. Nowak: Innowacyjne systemy budownictwa drewnianego w aspekcie rozwiązań konstrukcyjnych i fizyki budowli.....	189
M. Rojewska - Warchał: Analiza wpływu przeszklenia, ram oraz kształtu i wielkości okien na współczynnik przenikania ciepła $U$ .....	199
A. Zastawna - Rumina: Materiały fazowo-zmienne a temperatura wewnątrz pomieszczeń.....	207